

City of Scottsdale

2005



SUPPLEMENTAL
STANDARD DETAILS
FOR
PUBLIC WORKS
CONSTRUCTION

REVISED 5/26/05

2100 Series
General Information

- 2124 Accessible Signage
- 2131 Sign Post Installation
- 2132 * Raised Pavement Marker Layout
- 2133 * Median Nose Signing - Type A & B
- 2134-1 Street Name Signs - Type A
- 2134-2 Street Name Signs - Type B
- 2134-3 Street Name Signs - 18" And 24" Metro
- 2135 Street Name Sign Installation
- 2136 Advance Street Name Signs
- 2137 Loop Detectors
- 2138 Signal Pole Drilling Detail
- 2139 Traffic Signal Controller Cabinet Extender
- 2140 Model 330 Input Rack Wiring Instructions
- 2141 Tape Color Codes for Traffic Signal Wiring
- 2146-1 Refuse Enclosure
- 2146-2 Refuse Enclosure With Grease Containment Area
- 2147-1 Double Refuse Enclosure
- 2147-2 Double Refuse Enclosure With Grease Containment Area
- 2165-1 * 16' Sliding Gate & Hinged Door
- 2165-2 * 16' Sliding Gate

2200 Series
Street Information

- 2200 Pavement Replacement
- 2201 * Trench Bedding & Backfill
- 2202 Trench Plating
- 2207 Residential Unpaved Road
- 2210 Grading Behind The Curb
- 2220 Curb And Gutter - Types "A" & "B"
- 2221 Curb And Gutter - Types "M" & "W"
- 2225 Median Nose & Reverse Curve Details
- 2226 16' Median Nose Details

2200 Series
Street Information Cont'd

- 2228 Cut-Off Wall
- 2230 * Sidewalk Cut-Off For Utility Poles
- 2231 * Detectable Warning Surface
- 2232 * Directional Sidewalk Ramps
- 2233-1 * Directional Sidewalk Ramps Retrofit - Type A
- 2233-2 * Directional Sidewalk Ramps Retrofit - Type B
- 2234 * Shared Curb Sidewalk Ramp
- 2235-1 * Mid-Block Sidewalk Ramp - Type A
- 2235-2 * Mid-Block Sidewalk Ramp - Type B
- 2237 Sidewalk Pavers(Non-Traffic Bearing)
- 2238 Concrete Paver Crosswalk
- 2239 Median Concrete Pavers
- 2240 * 6' Valley Gutter & Apron
- 2250 Driveway Entrances
- 2255 * Residential Driveways
- 2256 * Commercial/Industrial Driveways-Type CL
- 2257 * Commercial/Industrial Driveways-Type CH
- 2258 * Commercial/Industrial Driveways-Type CI
- 2265-1 * Bus Shelter - Foundation Plan
- 2265-2 * Bus Shelter - Framing Plan
- 2265-3 * Bus Shelter - Sections
- 2265-4 * Bus Shelter - Details
- 2265-5 * Bus Shelter - Details
- 2265-6 * Bus Shelter - Notes
- 2265-7 * Bus Shelter - Abbreviations
- 2266-1 * Closed End Bus Bay - Type "A"
- 2266-2 * Closed End Bus Bay - Type "B"
- 2267 Far Side Bus Bay
- 2268 Base Slab And Foundations For Bus Stop Bench And Receptacles
- 2269 Transit Shelter Pad

2200 Series
Street Information Cont'd

- 2270 Frame & Cover Grade Adjustment
- 2281 Multi-Use Path Crossing Sign
- 2282 Multi-Use Path Striping And Signing
- 2283 Multi-Use Path Details
- 2284 Multi-Use Path Wet Crossing Sign
- 2285 * Double Bicycle Rack
- 2290 * Median Island Details
- 2292-1 * Speed Table Details
- 2292-2 * Speed Table Details
- 2293 * Mid-Block Pedestrian Table
- 2293 * Intersection Pedestrian Table
- 2294 * Pedestrian Refuge

2300 Series
Water Information

- 2305-1 Butterfly Valve Operator Manhole
- 2305-2 Butterfly Valve Operator Manhole
- 2315 Nonpotable Water Valve Box & Cover
- 2320 * Non-Potable Water Manhole Cover
- 2321 * Water Manhole Cover
- 2330 * Water Service Line Connection
- 2332 Chlorine Injection Tap
- 2333 Tap For Future Chlorine Injection
- 2342-1 Pressure Reducing Valve
- 2342-2 Pressure Reducing Valve
- 2345-1 3", 4", 6" Water Meter
- 2345-2 3", 4", 6" Water Meter
- 2346 * Temporary Construction Meter
- 2348 * Air / Vacuum Release Valve
- 2349 Water Quality Sampling Station

NOTE: * - Indicates New Or Revised Details For 2003 Supplement.

DETAIL NO.
2100-1

**City of Scottsdale
Standard Details**

INDEX

DETAIL NO.
2100-1

REVISED 4/20/05

2300 Series

Water Information Cont'd

- 2351 * Double Check Valve Backflow Prevention Assembly For Assemblies 3" Thru 10"
- 2352 * Double Check Valve Backflow Prevention Assembly For Assemblies 3/4" Thru 2 1/2"
- 2353 * Reduced Pressure Principle Backflow Prevention Assembly For Assemblies 3" Thru 10"
- 2354 * Reduced Pressure Principle Backflow Prevention Assembly For Assemblies 3/4" Thru 2 1/2"
- 2355 * Pressure Vacuum Breaker Assembly For Assemblies 1/2" Thru 2"
- 2356 Guard Posts For Backflow Prevention Assemblies
- 2357 Fill Pipe Details For Portable Tanks w/ Air Gap Separation
- 2358 Backflow Prevention For Portable Tanks With No Air Gap Separation
- 2359 * "N" Shaped Double Check Valve Backflow Prevention Assembly For Assemblies 3" Thru 10"
- 2360 * "N" Shaped Reduced Pressure Principle Backflow Prevention Assembly For Assemblies 3" Thru 10"
- 2362 * 1-1/2" - 2" Fire Line Connection
- 2363 Pavement Markers For Fire Hydrants
- 2364 * Fire And Emergency Access And Delineation
- 2365 * Fire Lane Sign
- 2366 * Concrete Collar For Fire Hydrants
- 2367 * Fire Department Remote Siamese Connection
- 2368 * Fire Sprinkler Riser Detail - Vertical Installation #1
- 2369 * Fire Sprinkler Riser Detail - Vertical Installation #2
- 2370 Vertical Realignment Of Water Mains
- 2372 Minimum Utility Separation Requirements

2300 Series

Water Information Cont'd

- 2380 * Temporary Water Supply Hydrant Meter Assembly
- 2381 * Temporary Blow-Off For Water Supply
- 2382 * Temporary Water Service
- 2397 * Electronic Ballmarker Placement
- 2398 * Antenna Mast Detail

2400 Series

Sanitary Sewer Information

- 2402 Force Main Discharge Manhole
- 2403 2-Way F.M. Cleanout, 3" & Above
- 2404 F.M. Cleanout W/ Sewer Release A.V.
- 2405 Sewer Air Release Valve
- 2420 Water Tight Concrete Sewer Manhole
- 2421 * Sanitary Sewer Manhole Cover
- 2440 * Sewer Building Connection
- 2460 Monitoring/Sampling Vault

2500 Series

Irrigation & Storm Drain Information

- 2508 Handrail Detail
- 2515-1 Wall Opening & Erosion Protection - Type 1
- 2515-2 Drainage Grate At Block Wall
- 2515-3 Wall Opening Erosion Protection - Type 2
- 2520* Storm Drain Manhole Cover
- 2535 Catch Basin Grates
- 2554 Concrete Invert Paving For Corrugated Metal Pipe And Pipe Arch
- 2560-1* Storm Drain Inlet Marker
- 2560-2* Storm Drain Inlet Marker On Headwall
- 2560-3* Storm Drain Inlet Marker On Catch Basin/Scupper
- 2562-1 Storm Sewer Outfall Access Barrier
- 2562-2 Barrier Specifications Schedule

2600 Series

Landscape Information

- 2600-1 Minimum Tree Size Requirements
- 2600-2 Minimum Tree Size Requirements
- 2600-3 Minimum Tree Size Requirements
- 2620-1 Landscape Details
- 2620-2 Landscape Details
- 2620-3 Landscape Details
- 2631 Irrinet Pedestal Mounted Controller
- 2632 Scorpio Pedestal Mounted Controller
- 2633 Scorpio Wall Mounted Controller
- 2634 Irrinet Wall Mounted Controller
- 2635-1 Solar Controller
- 2635-2 Solar Controller & Backflow Enclosure
- 2636 Irrigation Push Button Control
- 2641-1 Single & Multi-Outlet Emitters
- 2641-2 Irrigation Emitter Layout
- 2642 * Irrigation Trenching
- 2643 Irrigation Thrust Block
- 2644 Rotor Sprinkler Assembly
- 2645 Pop-Up Sprinkler Assembly
- 2646 Shrub Pop-Up Sprinkler Assembly
- 2647 Drip Filter & Pressure Regulator
- 2648 Emitter Flush Cap Assembly
- 2649 Quick Coupler Assembly
- 2650 1-1/2" & Smaller Mainline Ball Valve
- 2651 2" & Larger Mainline Isolation Valve
- 2652 2"Or Smaller Master Valve/Flow Meter
- 2653 3"Or Larger Master Valve/Flow Meter
- 2654 * Remote Control Valve Assembly
- 2655 * Typical Irrigation Wire Connection
- 2680-1 Trail Access Gates
- 2680-2 Trail Access Gates
- 2681 Trail Water Bars
- 2682 Trail Safety Barriers
- 2683 Trail Signs

NOTE: * - Indicates New Or Revised Details For 2003 Supplement.

DETAIL NO.
2100-2

**City of Scottsdale
Standard Details**

INDEX

DETAIL NO.
2100-2

REVISED 2/26/01

NOTE:

Lettering shall be FHWA Series "B" alphabet, or Helvetica Med. Cond.

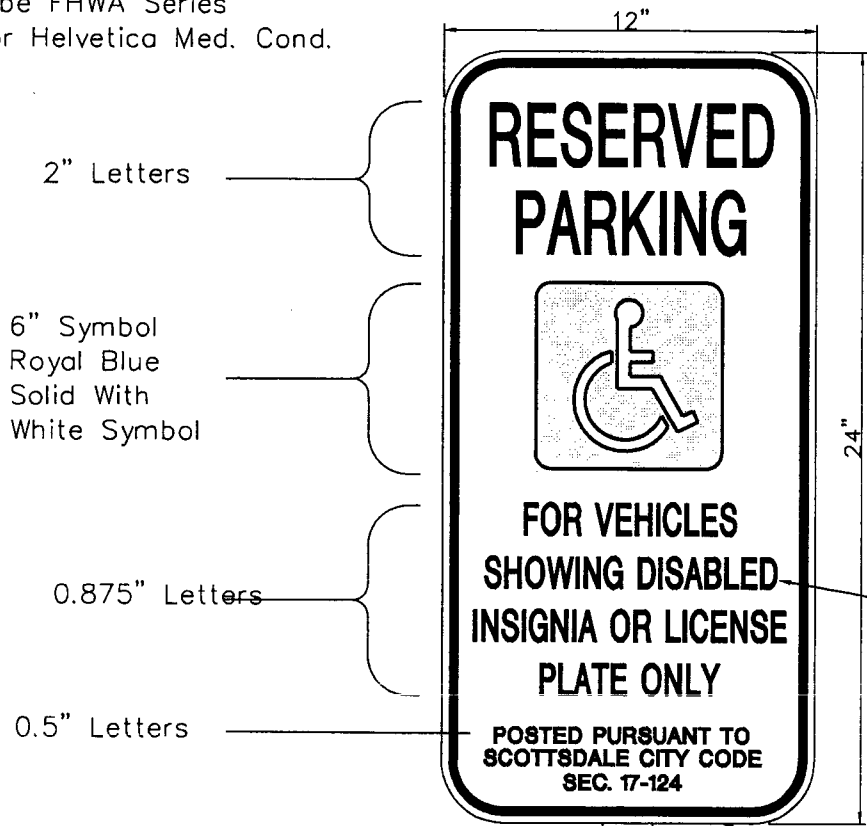

MOUNTING OPTIONS (SEE PLANS)

- A) Flexible P.E. Post With Surface Mount Base – Epoxy To Pavement Surface
- B) Perforated Galvanized Tubing Per COS Detail 2131. Install In Landscape Areas Only.
- C) Surface Mount To Structure
- D) Mount As Detailed On Plans

Green Borders and Text, and Blue Symbol on White Retroreflective Background (Typ.)
 Background: Super Engineer Grade Or High Intensity Sheeting
 Copy: Same As Above
 Substrate: 0.080 Gauge Treated Aluminum

Bottom Of Sign Shall Be Not Less Than 3 Feet Nor More Than 6 Feet Above Finish Surface

ACCESSIBLE SIGNAGE

One Sign At Each Accessible Parking Stall

DETAIL NO. **2124** **City of Scottsdale Standard Details**

APPROVED BY: **Scottsdale Standards & Specifications Committee**

ACCESSIBLE SIGNAGE

DETAIL NO. **2124**

REVISED 1/3/94

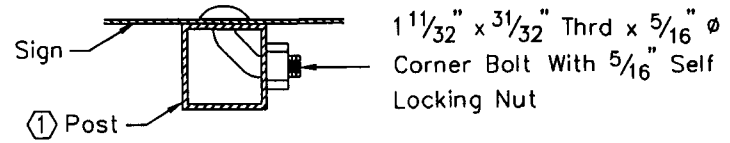
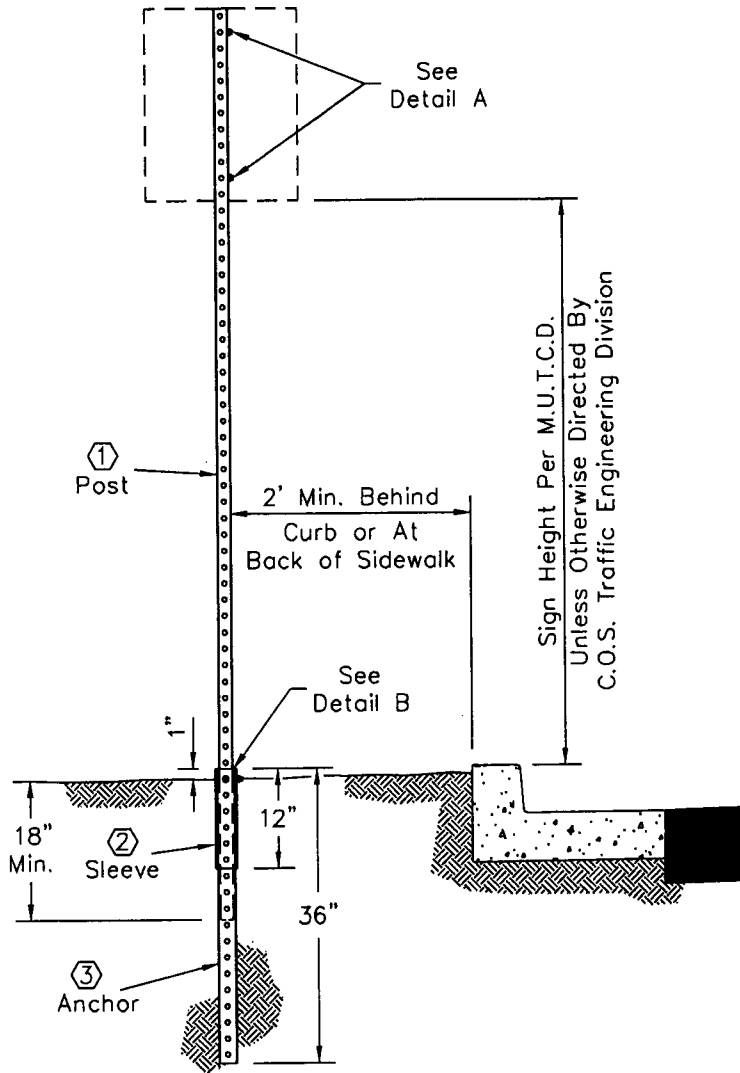

**Detail A
Sign Mounting**

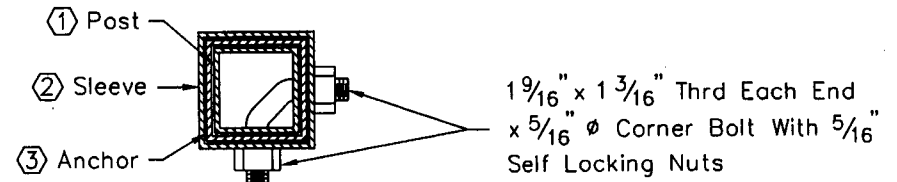

**Detail B
Anchor Assembly**

Legend

- ① Post - 1-3/4" x 1-3/4" Square Perforated 0.105" Galvanized Steel Tubing (Green Finish)
- ② Sleeve - 2-1/4" x 2-1/4" x 12", Square Perforated 0.105 Galvanized Steel Tubing (Green Finish)
- ③ Anchor - 2" x 2" x 36", Square Perforated 0.105" Galvanized Steel Tubing (Green Finish)

NOTE:

1. Sign Post, Sleeve And Anchor Per COS Supplemental Spec. Section 402.3

DETAIL NO.
2131

**City of Scottsdale
Standard Details**

APPROVED BY:
**Scottsdale Standards &
Specifications Committee**

SIGN POST INSTALLATION

DETAIL NO.
2131

REVISED 5/25/05

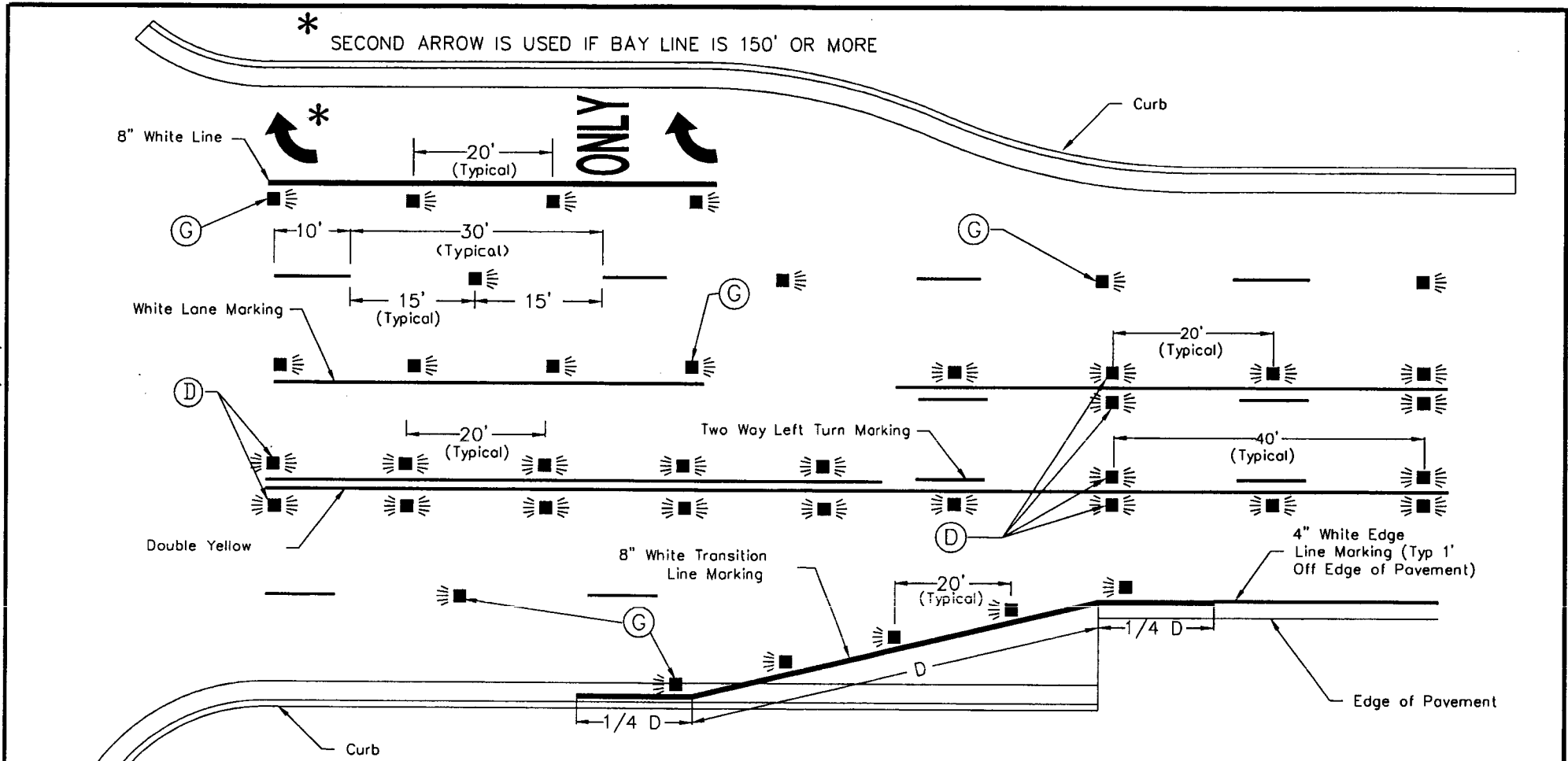

REFERENCE ADOT STD DRAWING M-19 FOR RAISED PAVEMENT MARKERS.

SEE STANDARD DETAIL 2363 FOR FIRE HYDRANT MARKERS

LEGEND

- ⓐ - TYPE "G" WHITE, ONE WAY REFLECTIVE
- ⓓ - TYPE "D" YELLOW, TWO WAY REFLECTIVE

DETAIL NO. 2132	City of Scottsdale Standard Details	APPROVED BY: Scottsdale Standards & Specifications Committee	RAISED PAVEMENT MARKER LAYOUT	DETAIL NO. 2132
---------------------------	---	--	--------------------------------------	---------------------------

Revised 5/25/05

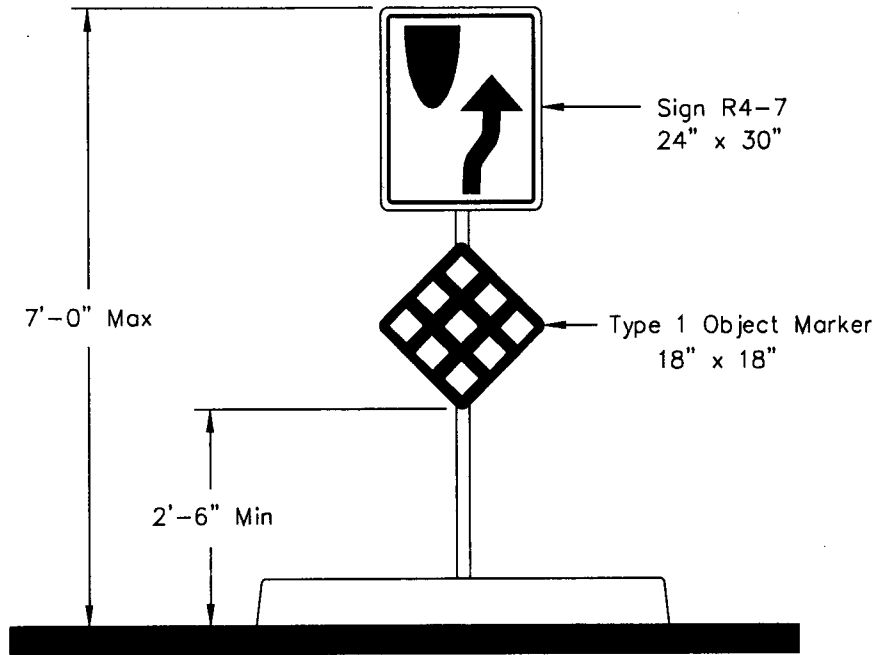

TYPE "A"

(AT SIGNALIZED INTERSECTIONS
OR AS SHOWN ON PLANS AND FIRST &
LAST NOSE ON A STRING OF MEDIANS)

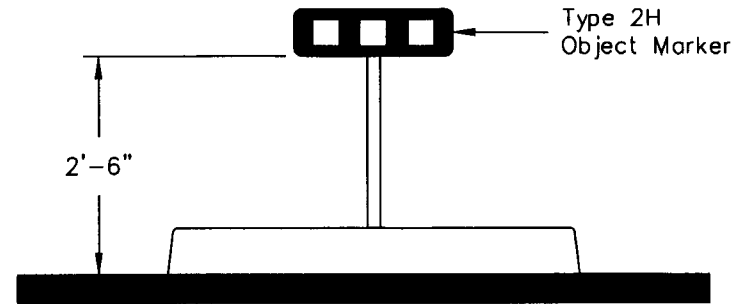

TYPE "B"

(ALL OTHER MEDIANS)

NOTES:

1. See COS Std Det 2225 Or 2226
For Typical Location.
2. Sign Posts Per COS Std Det 2131.

DETAIL NO. **2133** **City of Scottsdale**
Standard Details

APPROVED BY:
**Scottsdale Standards &
Specifications Committee**

MEDIAN NOSE SIGNING-TYPE A&B

DETAIL NO. **2133**

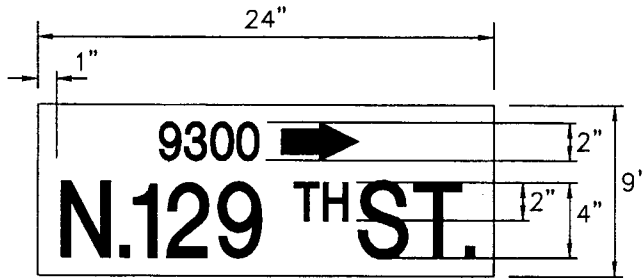

TYPE A SIGNS

Type IIA Super Engineering Grade
Green/White (2 Sides)

Blank Sizes: 9"x 24", 9"x 30",
9"x 36", 9"x 42"

Intended Usage: Type "A" Street Name Signs shall be used in residential areas where Residential Streets intersect with Local Collector Streets. See the COS General Plan for Street Designations.

DETAIL NO.
2134-1

City of Scottsdale
Standard Details

APPROVED BY:
Scottsdale Standards &
Specifications Committee

STREET NAME SIGNS - TYPE A

DETAIL NO.
2134-1

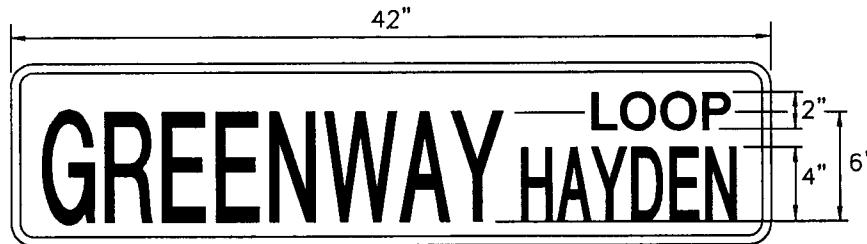
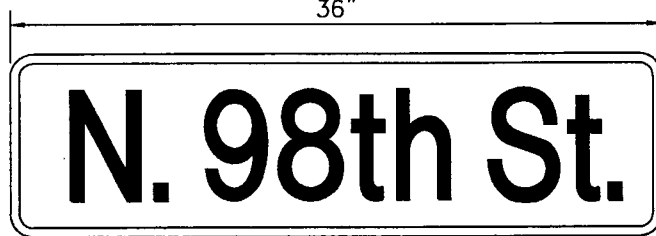

TYPE B SIGNS

Type III High Intensity Grade
Green/White (2 Sides)

Blank Sizes: 10"x 36", 10"x 42"

Intended Usage: Type "B" Street Name Signs shall be used where a Residential Street or a Local Collector Street intersects with a street with a classification of Major Collector or larger. See the COS General Plan for Street Designations.

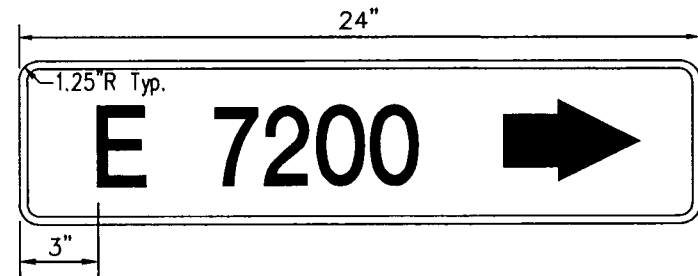
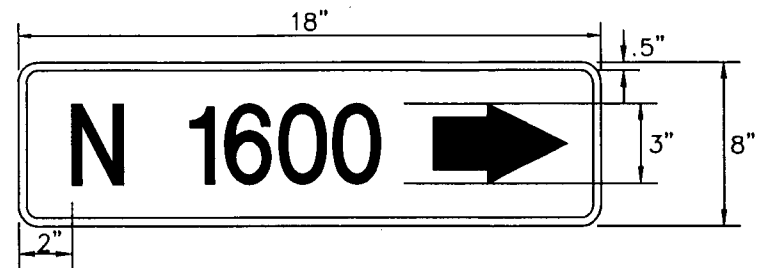

TYPE B BLOCK NUMBERS

Type III High Intensity Grade
Green/White (1 Side)

Blank Sizes: 8"x 18", 8"x 24"

Type "B" Block Numbers to be mounted with Type "B" Street Name Signs.

DETAIL NO.
2134-2

**City of Scottsdale
Standard Details**

APPROVED BY:
**Scottsdale Standards &
Specifications Committee**

STREET NAME SIGNS - TYPE B

DETAIL NO.
2134-2

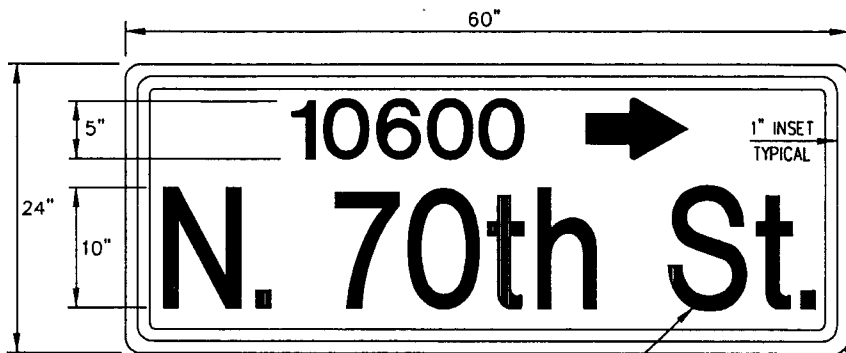

UPPER & LOWER CASE ON
NUMERIC STREET NAMES



USE SMALLER SIZE LETTERS
FOR THESE TYPES

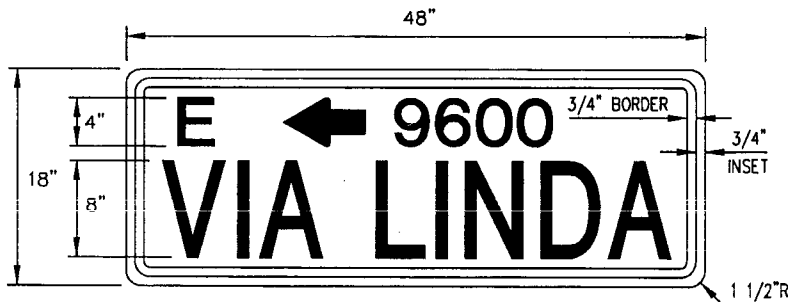

18" METRO SIGNS

Diamond Grade Intensity – Green/White (1 Side)

Typestyle = Highway Gothic, Modify C or D

Blank Sizes: 18"x 48", 18"x 60", 18" x 72"

Intended Usage: 18" Metro Street Name Signs shall be used on minor roads with a speed limit of 35MPH or lower. See the COS General Plan for Street Designations.

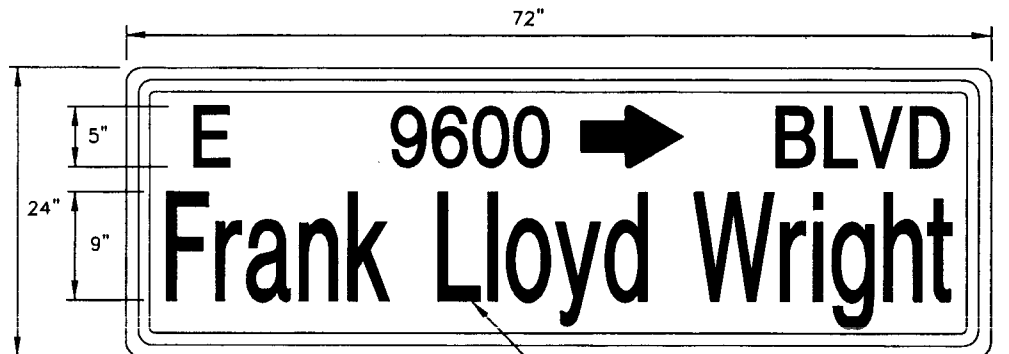

FOR STREET NAMES THAT WOULD EXCEED
MAXIMUM LENGTH SIGN BLANK USE 9"
UPPER AND LOWER CASE LETTERS

24" METRO SIGNS

Diamond Grade Intensity – Green/White (1 Side)

Typestyle = Highway Gothic, Modify C or D

Blank Sizes: 24"x 60", 24"x 72", 24" x 84"

Intended Usage: 24" Metro Street Name Signs shall be used on major roads with a speed limit of 35MPH or higher. See the COS General Plan for Street Designations.

DETAIL NO.
2134-3

City of Scottsdale
Standard Details

APPROVED BY:
Scottsdale Standards &
Specifications Committee

STREET NAME SIGNS - 18" AND 24" METRO

DETAIL NO.
2134-3

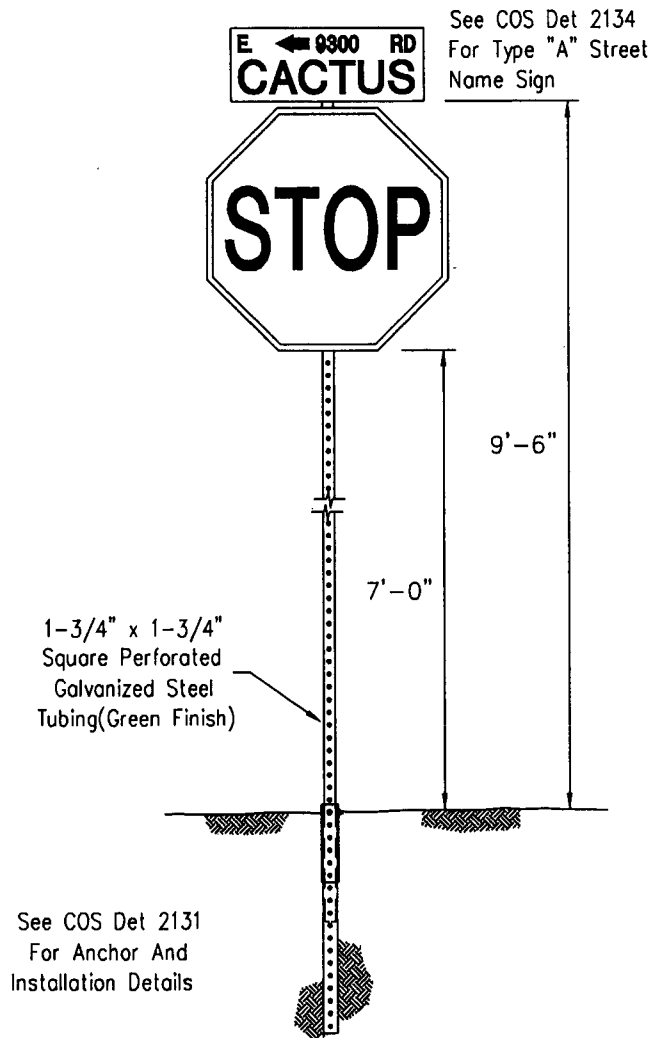

NOTES:

Street name sign and stop sign mounting height shall be measured from adjacent grade of sidewalk, top of curb or top of nearest pavement.

When no stop sign is required the street name sign is mounted at 9 feet 6 inches.

When two street name signs are mounted one on top of the other, the height is measured to the bottom sign.

DETAIL NO.
2135

**City of Scottsdale
Standard Details**

APPROVED BY:
**Scottsdale Standards &
Specifications Committee**

STREET NAME SIGN INSTALLATION

DETAIL NO.
2135

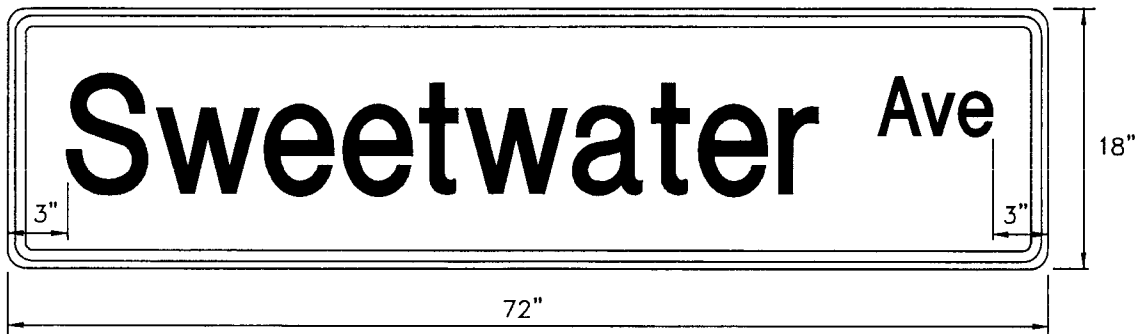
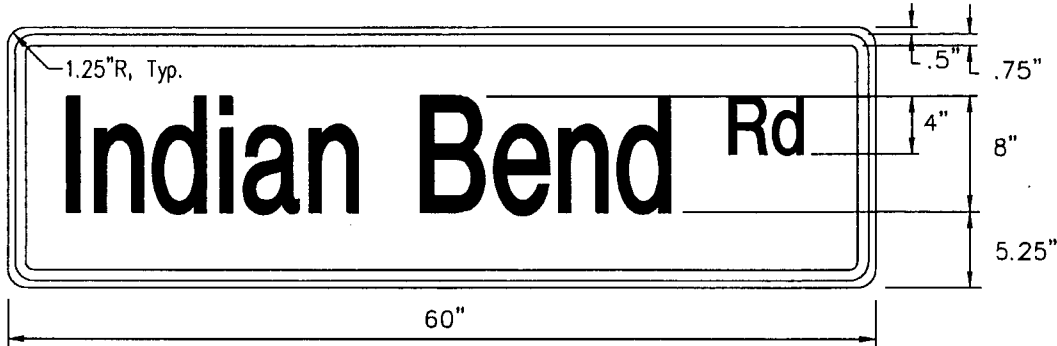

Type III High Intensity, Green/White (1 Side)
 Blank Sizes: 18"x 48", 18"x 60", 18"x 72"

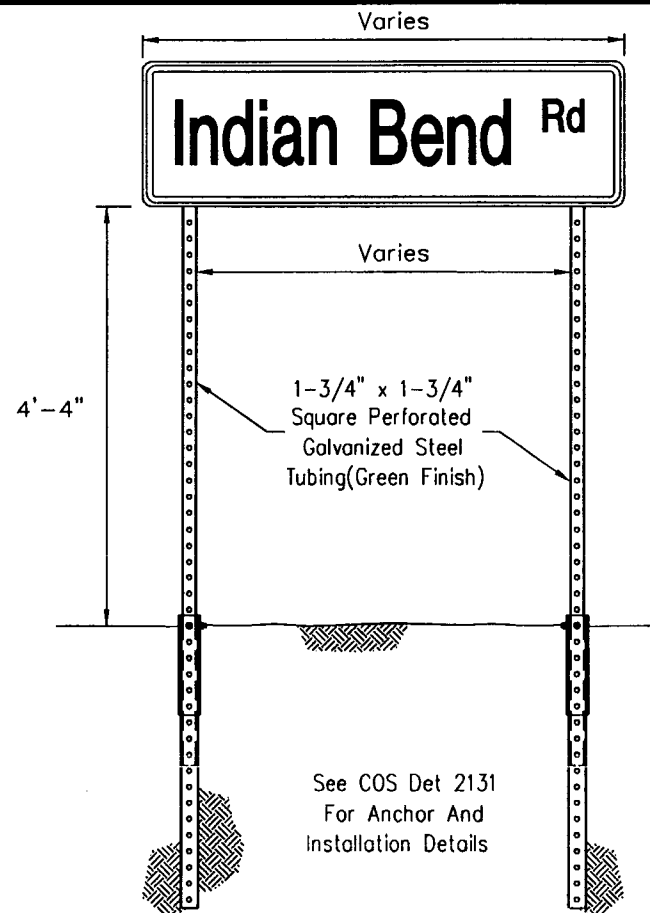

Intended Usage: To be used in advance of the specified street where an unsignalized collector street intersects a minor/major arterial or expressway. Location determined by multiplying the posted speed limit by 10. Sign is typically placed in a median when available, otherwise on the right hand side of the road.

DETAIL NO.
2136

City of Scottsdale
Standard Details

APPROVED BY:
Scottsdale Standards &
Specifications Committee

ADVANCE STREET NAME SIGNS

DETAIL NO.
2136

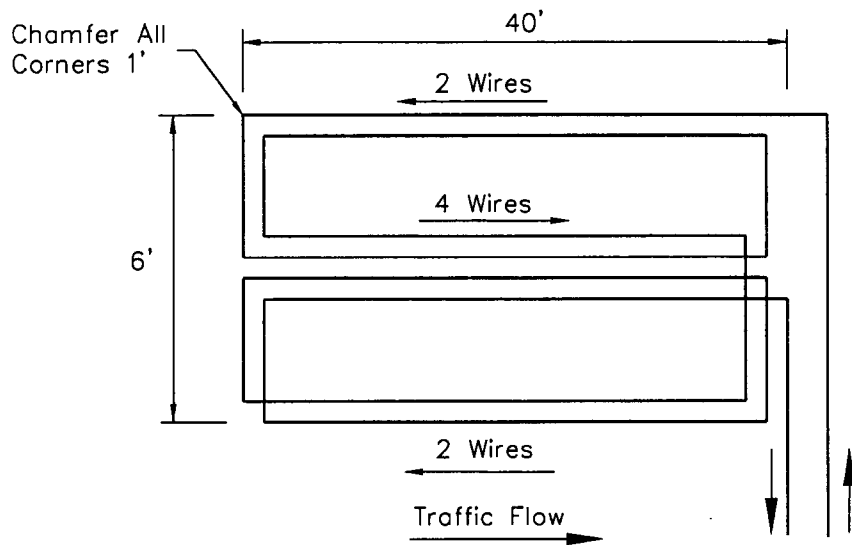

QUADRUPOLE LOOP DETECTOR
For Left Turn Lanes Only

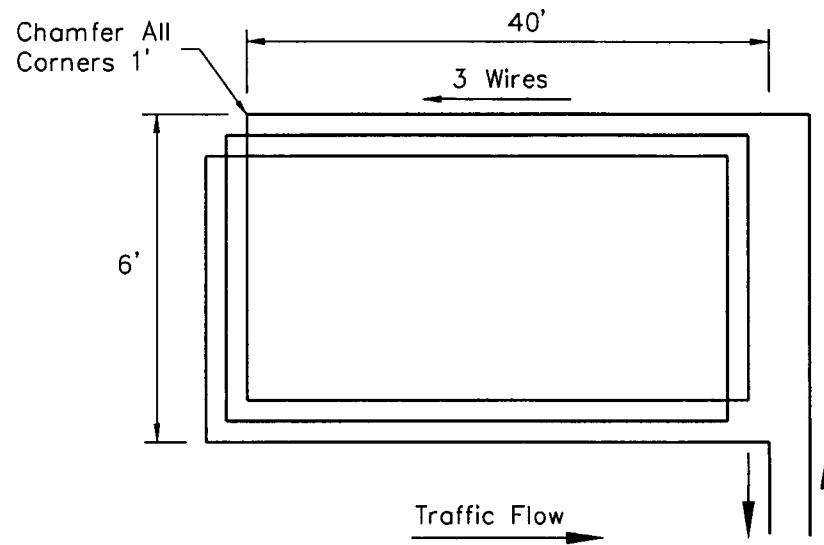

STANDARD LOOP DETECTOR

NOTES:

1. All loop detectors shall be wire-in-duct type wire. (Detect-a-Duct or approved equivalent, #14 stranded inside a 1/4" PVC tubing (IMSA 51-5).
2. All loop detectors shall be centered in the middle of the applicable traffic lane. Loop shall be sufficiently dimensioned on the plans. Loop detectors shall extend five feet into the crosswalk unless directed otherwise by the Traffic Engineering Department.
3. A rectangular loop with 3 turns (6 feet x 40 feet) shall be used for all through lanes.
4. A quadrupole loop with 2 outside turns and 4 inside turns (6 feet x 40 feet) shall be used in all exclusive left-turn lanes. (Wire in middle cut shall run the same direction).
5. Loop detectors shall not be installed in exclusive right turn lanes.
6. The location of permanent count detector loops shall be specified by the Traffic Engineering Department. Count detector loops shall consist of a minimum of 4 turns (6 feet x 6 feet).
7. Pre-formed loop detectors conforming to the latest ADOT specifications shall be used under decorative pavement, "pavers", concrete, or other "special" roadway surfaces, or as directed by the Traffic Engineering Department.
8. Lead-in cable between loop wire and controller shall be latest ADOT specification or approved equivalent (IMSA 50-2).
9. Loop lead-in and splices in pull box shall be twisted and soldered. Griggs Loop Detector Sealant, 3-M Loop Sealant, or approved equivalent shall be used.
10. Loops shall be installed prior to the installation of the final pavement lift (if part of a paving project).
11. Loops shall be inspected and tested prior to acceptance by the City.
12. See ADOT TS 7-1 for installation details.

DETAIL NO.
2137

City of Scottsdale
Standard Details

APPROVED BY:
Scottsdale Standards & Specifications Committee

LOOP DETECTORS

DETAIL NO.
2137

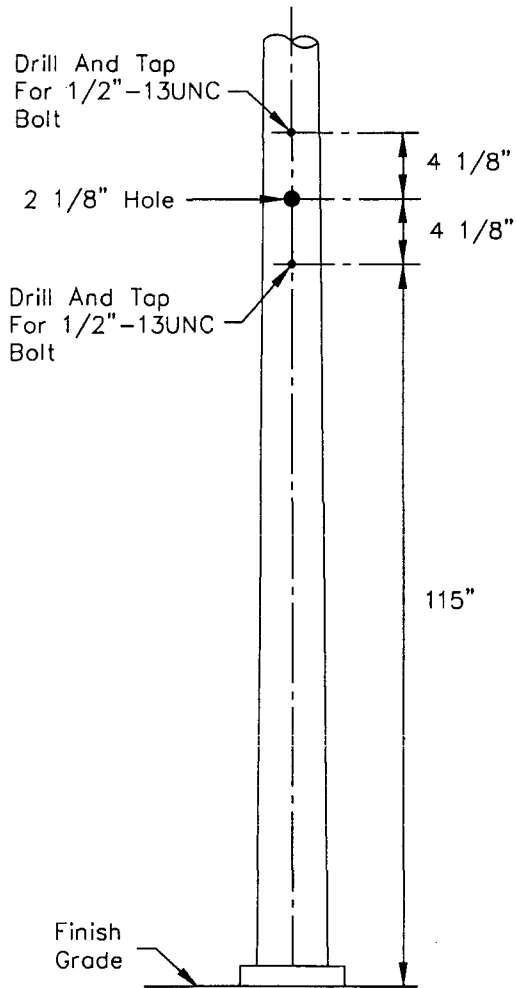

SIDE MOUNT DRILLING DETAIL

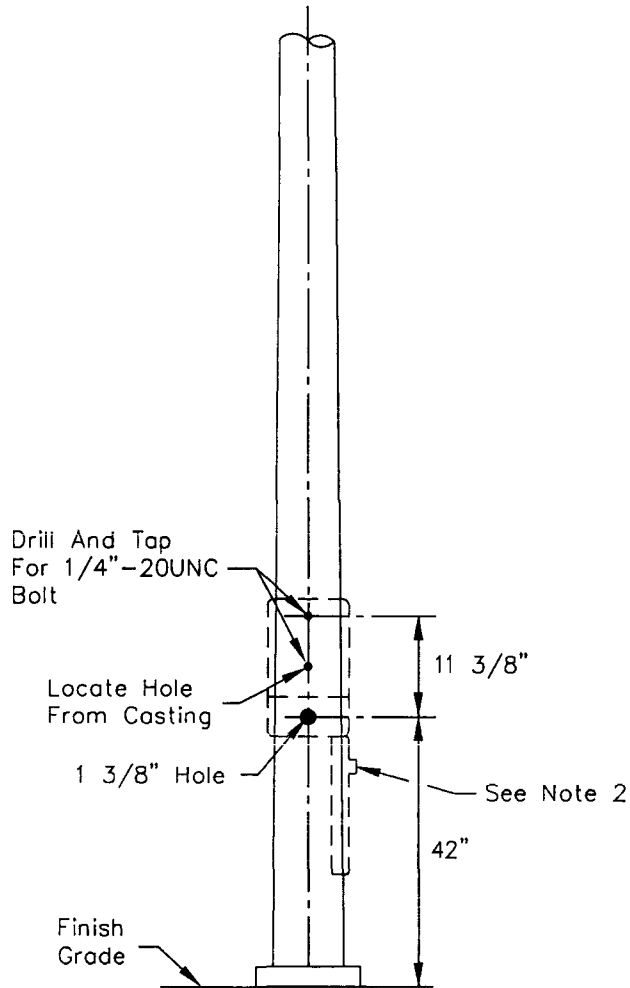

PUSH BUTTON DRILLING DETAIL

NOTES:

1. Drilling of pole to be oriented according to pole layout, or as directed by C.O.S. Engineer in the field.
2. When two pedestrian push button assemblies are mounted on a small diameter pole the lower assembly shall be positioned upside down so that the push button is at the top and the sign is below.
3. Top mounting holes to be field drilled in order to allow for manufacturing variations.
4. Push button shall be A.D.A large target style (ADOT Type I).

DETAIL NO.
2138

**City of Scottsdale
Standard Details**

APPROVED BY:
**Scottsdale Standards &
Specifications Committee**

SIGNAL POLE DRILLING DETAIL

DETAIL NO.
2138

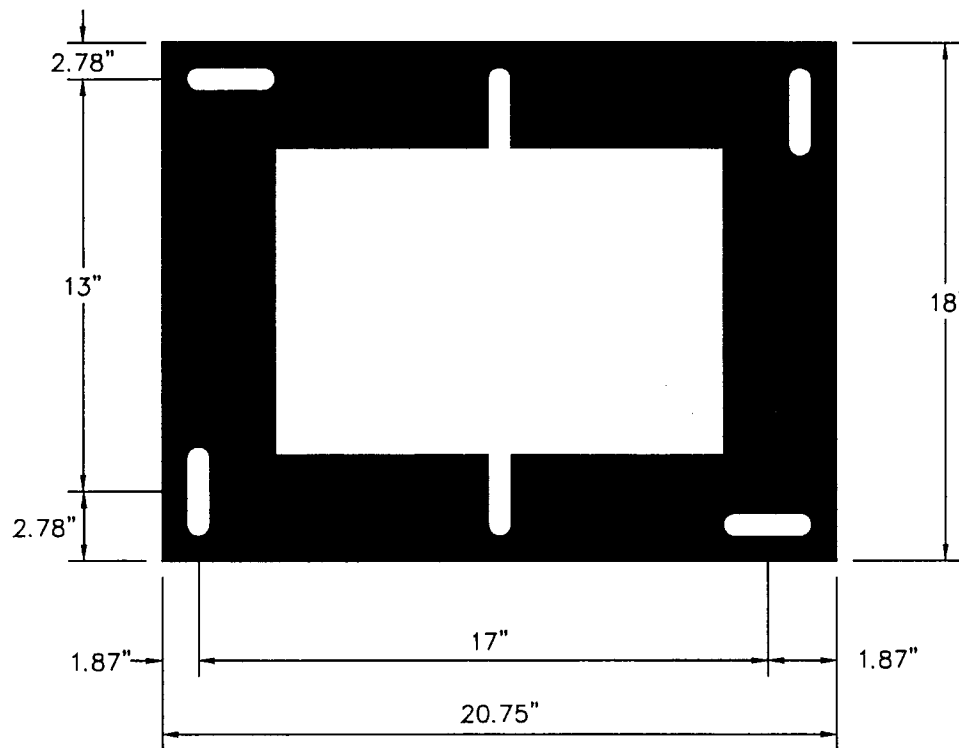

INSIDE VIEW OF BOTH
SIDES OF BASE EXTENDER

1. Model 330 cabinet base extenders will include cutouts that will accommodate replacement with all other Scottsdale 330 cabinets and model 336S. These base extenders are available from the cabinet manufacturer. All Scottsdale cabinets are foundation mounted.
2. Foundation must include a 4" x 24" x 24" concrete pad in front of the cabinet door.
3. The cabinet shall be mounted in such a way that when the technician has the door open and is facing the cabinet, he is also facing the intersection.
4. Cabinet base extender shall have a 12" x 12" removable access panel. Base extender shall be installed so that access panel is on door side of cabinet.

DETAIL NO.
2139

City of Scottsdale
Standard Details

APPROVED BY:
**Scottsdale Standards &
Specifications Committee**

TRAFFIC SIGNAL CONTROLLER CABINET BASE EXTENDER

DETAIL NO.
2139

LOOP AND PEDESTRIAN PUSH BUTTON INPUTS

Slot 1	Slot 2	Slot 3	Slot 4	Slot 5	Slot 6	Slot 7	Slot 8	Slot 9	Slot 10	Slot 11	Slot 12	Slot 13	Slot 14
1 AB Ph 1	3 AB Ph 2	5 AB Ph 3	7 AB Ph 4	9 AB Ph 5	11 AB Ph 6	13 AB Ph 7	15 AB Ph 8	17 AB 2 PPB	19 AB 4PPB	21 AB RRPre	23 AB AdvEn	25 AB EV A	27 AB Stop Time
2 AB Ph 1	4 AB Ph 2	6 AB Ph 3	8 AB Ph 4	10 AB Ph 5	12 AB Ph 6	14 AB Ph 7	16 AB Ph 8	18 AB 6 PPB	20 AB 8PPB	22AB Flash	24 AB Adv	26 AB EV B	28 AB 6 Call
Det Loops	Det Loops	Det Loops	Det Loops	Det Loops	Det Loops	Det Loops	Det Loops	Ped Push Buttons	Ped Push Buttons	-----	-----	Pre- Empt	Slot 14 ----- Slot 14

1. All Scottsdale model 330 cabinet input racks have 14 slots.
2. Slots 1–8 are for vehicle detector loops.
3. Phase 4 loops are terminated on slot 4 (7A&B and/or 8A&B).
4. Phase 4 pedestrian push button is terminated on 19A and ppb neutral on 19B.
5. 19B shall have a jumper to the neutral bar.
6. All two phase intersections are to be wired to phases 2 and 4.
7. Field output wiring for 2 phase signals shall be wired to 2R, 2Y, 2G and 4R, 4Y, 4G.
8. Ped field wiring shall be wired to 9R, 9G (Phase 2 Ped) and 10R, 10G (Phase 4 Ped).
9. Call COS Traffic Signals (480)312–5635 prior to wiring cabinet for instructions for intersections with more than 2 phases.

DETAIL NO.
2140

**City of Scottsdale
Standard Details**

APPROVED BY:
**Scottsdale Standards &
Specifications Committee**

MODEL 330 INPUT RACK WIRING INSTRUCTIONS

DETAIL NO.
2140

MAIN DIRECTIONS

Direction	Color
WB	Blue
EB	Green
NB	Red
SB	Yellow

**LEFT TURN DIRECTIONS
(Main Color + White)**

Direction	Color
WBLT	Blue + White
EBLT	Green + White
NBLT	Red + White
SBLT	Yellow + White

**RIGHT TURN DIRECTIONS
(Main Color + Black)**

Direction	Color
WBRT	Blue + Black
EBRT	Green + Black
NBRT	Red + Black
SBRT	Yellow + Black

**Color Of Wire For
Power/Neutrals/Pushbuttons**

Wire	Color
AC+ Power	Black
AC- (Neutral)	White
24V Pushbutton	Orange, Stranded

WBLT = West Bound Left Turn and shall be the phase for vehicles facing west and turning to south
 EBLT = East Bound Left Turn and shall be the phase for vehicles facing east and turning to north
 NBLT = North Bound Left Turn and shall be the phase for vehicles facing north and turning to west
 SBLT = South Bound Left Turn and shall be the phase for vehicles facing south and turning to east

WBRT = West Bound Right Turn and shall be the phase for vehicles facing west and turning to north
 EBRT = East Bound Right Turn and shall be the phase for vehicles facing east and turning to south
 NBRT = North Bound Right Turn and shall be the phase for vehicles facing north and turning to east
 SBRT = South Bound Right Turn and shall be the phase for vehicles facing south and turning to west

DETAIL NO.
2141

**City of Scottsdale
Standard Details**

APPROVED BY:
**Scottsdale Standards &
Specifications Committee**

TAPE COLOR CODES FOR TRAFFIC SIGNAL WIRING

DETAIL NO.
2141

REVISED 5/9/02

NOTE:

1. 1/2" Expansion Joint, ASTM D-1751 Per MAG Section 729.

30' x 14' x 6" Thick Concrete Approach Slab With Thickened Edges, Class "B" Concrete w/ 6"x 6", 1.4 x 1.4 WWF, On Compacted Subgrade. Approach Slab Shall Have A Constant Slope Which Matches The Enclosure Slab.

30' x 14' x 6" Thick Concrete Approach Slab With Thickened Edges, Class "B" Concrete w/ 6"x 6", 1.4 x 1.4 WWF, On Compacted Subgrade. Approach Slab Shall Have A Constant Slope Which Matches The Enclosure Slab.

* In locations where a 30' approach slab is not possible, approval from the City of Scottsdale Quality Compliance Division is required.

8" CMU Or Block Or Stucco To Match Building

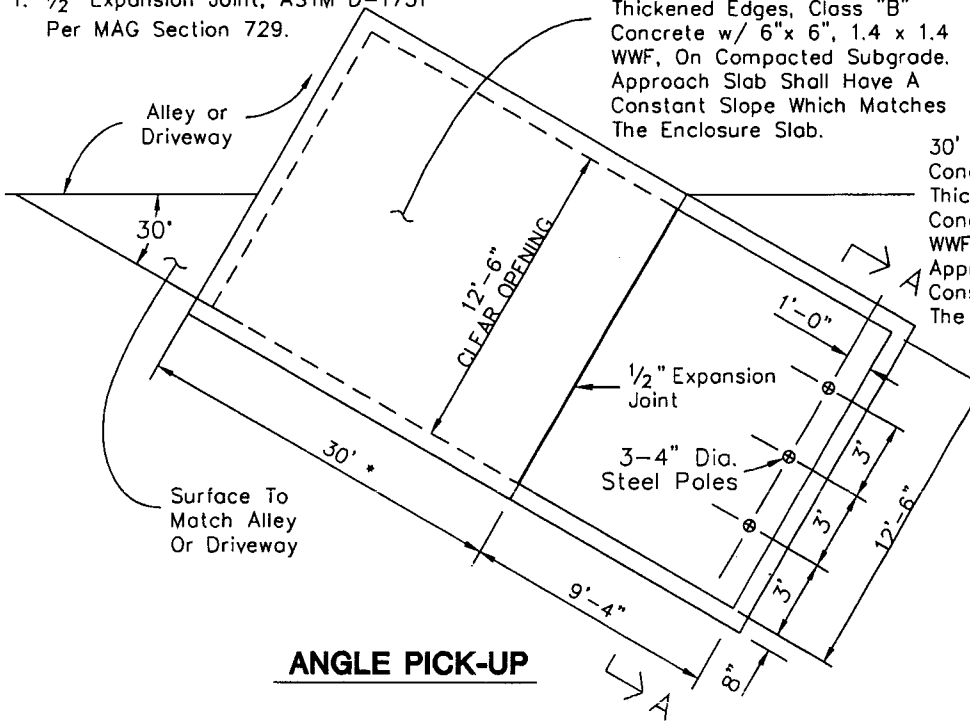

ANGLE PICK-UP

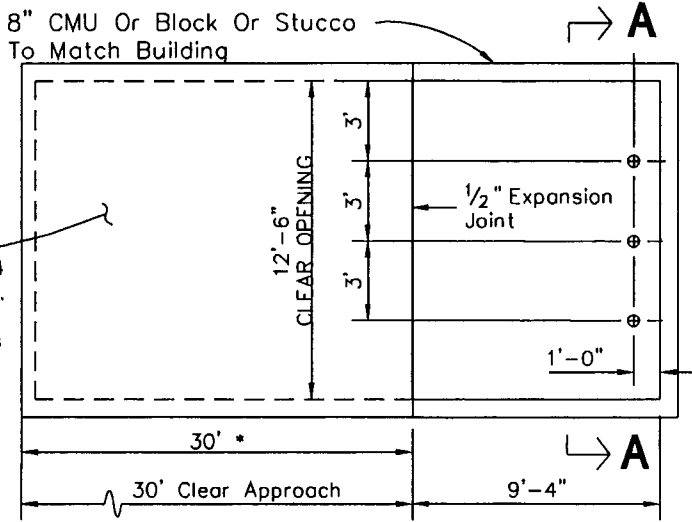

HEAD ON PICK-UP

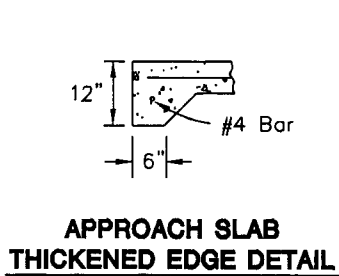

APPROACH SLAB THICKENED EDGE DETAIL

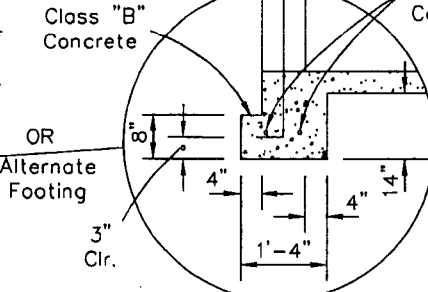
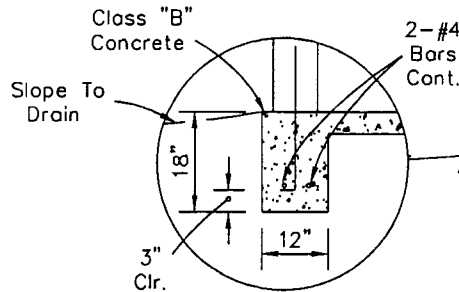

Place 3-4" Dia. Steel Poles 60" Above Grade Cap Or Grout Full. Paint To Match Wall Color.

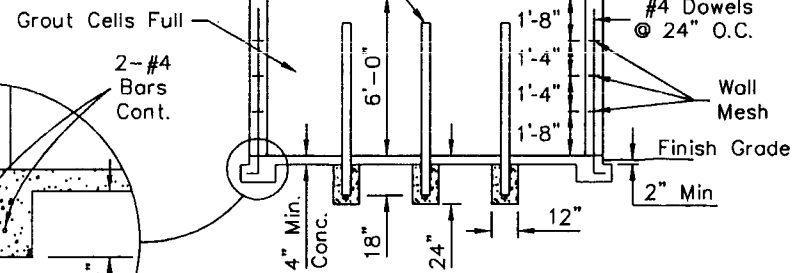

SECTION A-A

DETAIL NO. **2146-1** City of Scottsdale Standard Details

APPROVED BY: **Scottsdale Standards & Specifications Committee**

REFUSE ENCLOSURE

DETAIL NO. **2146-1**

REVISED 5/9/02

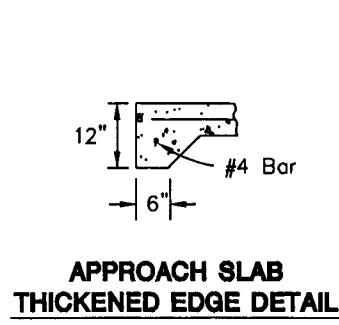
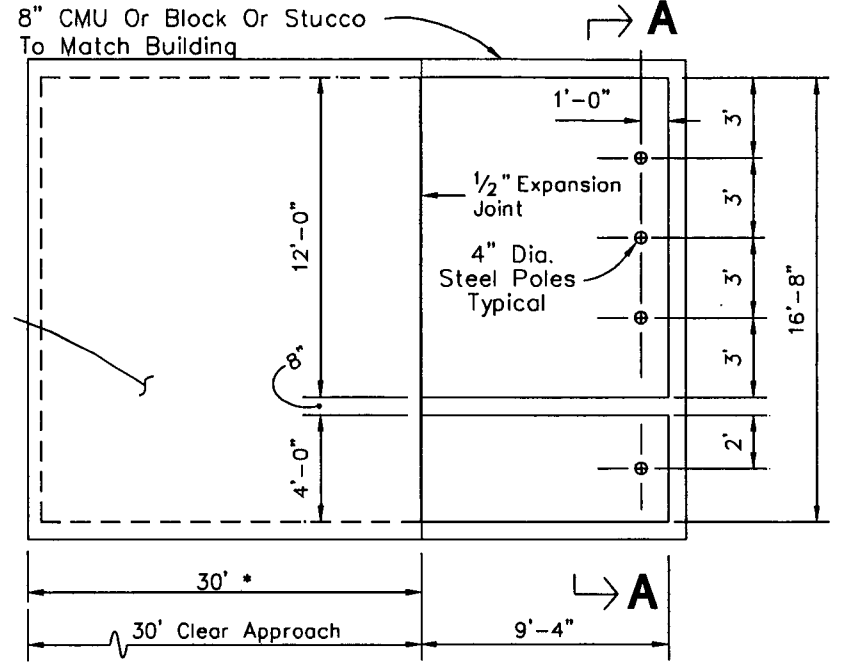
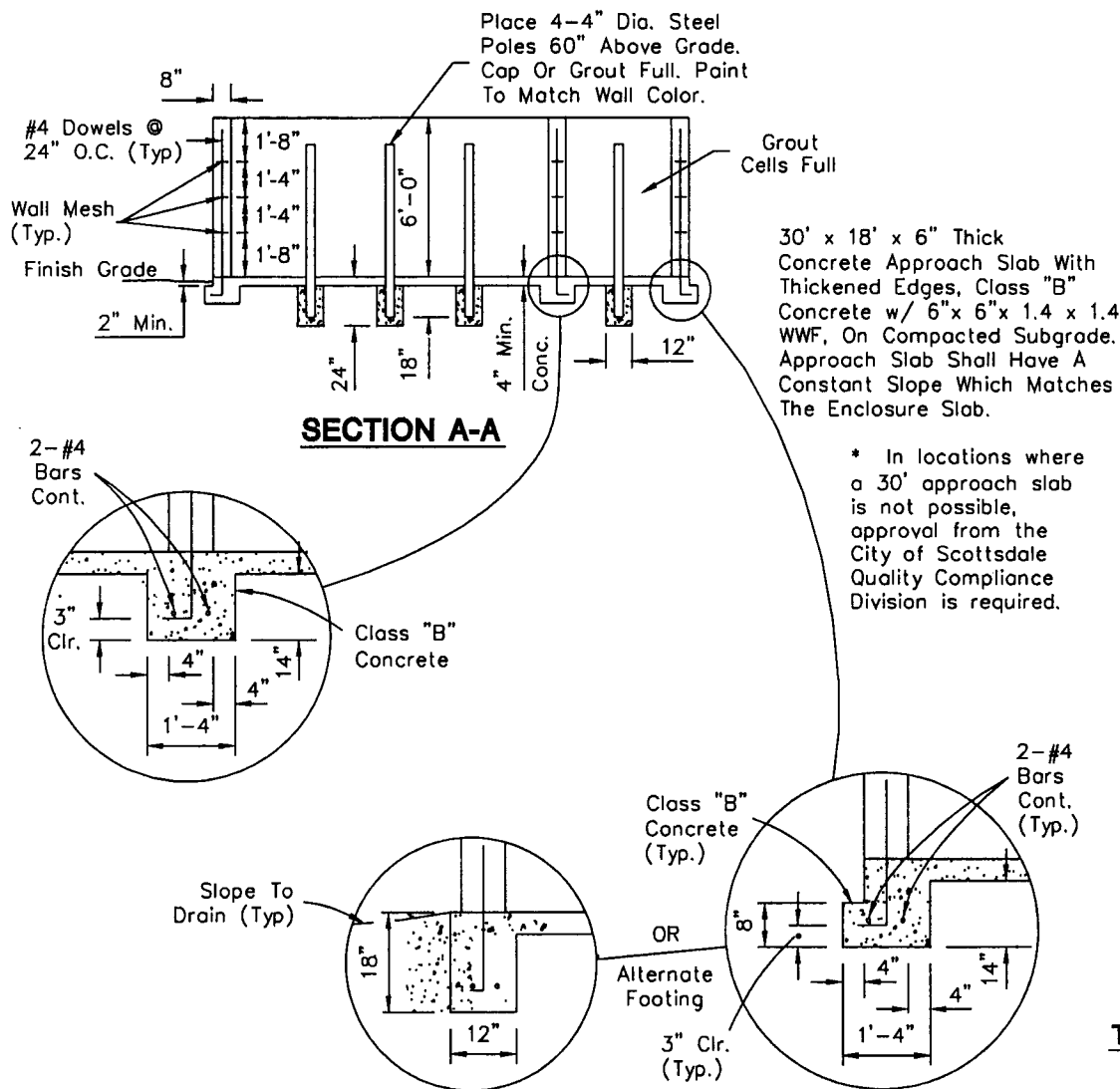

- NOTES:**
1. Enclosure For Angle Pick-up Similar To COS Detail 2146-1
 2. 1/2" Expansion Joint, ASTM D-1751 Per MAG Section 729.

REVISED 5/9/02

Place 6-4" Dia. Steel Poles 60" Above Grade Cap Or Grout Full. Paint To Match Wall Color.

Grout Cells Full

#4 Dowels @ 24" O.C.

Class "B" Concrete

2-#4 Bars Cont.

SECTION A-A

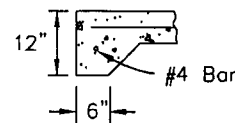

APPROACH SLAB THICKENED EDGE DETAIL

OR Alternate Footing

Slope To Drain (Typ)

2-#4 Bars Cont.

Class "B" Concrete

8" CMU Or Block Or Stucco To Match Building

30' x 23' x 6" Thick Concrete Approach Slab With Thickened Edges, Class "B" Conc. w/ 6"x 6", 1.4 x 1.4 WWF, On Compacted Subgrade. Approach Slab Shall Have A Constant Slope Which Matches The Enclosure Slab.

* In locations where a 30' approach slab is not possible, approval from the City of Scottsdale Quality Compliance Division is required.

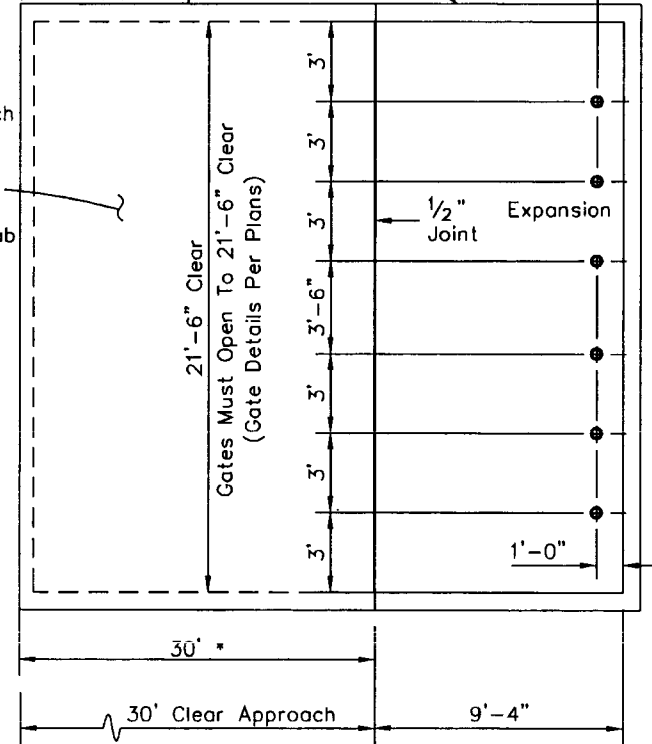

PLAN

NOTE:

1. Double Enclosure For Angle Pick-Up Similar To COS Det. 2146-1
2. 1/2" Expansion Joint, ASTM D-1751 Per MAG Section 729.

DETAIL NO. **2147-1** City of Scottsdale Standard Details

APPROVED BY: **Scottsdale Standards & Specifications Committee**

DOUBLE REFUSE ENCLOSURE

DETAIL NO. **2147-1**

REVISED 5/9/02

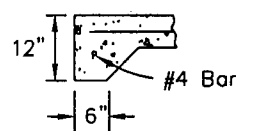
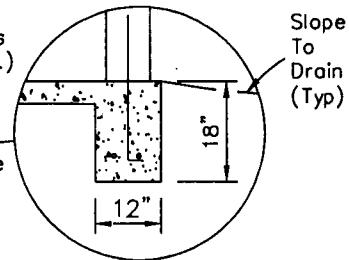
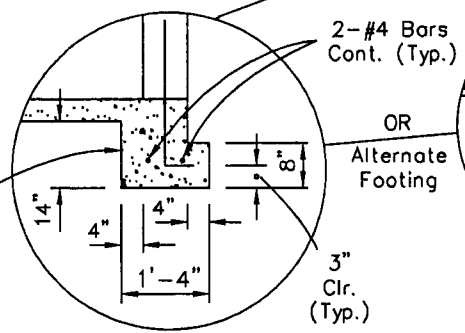
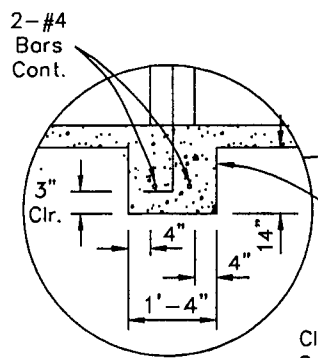
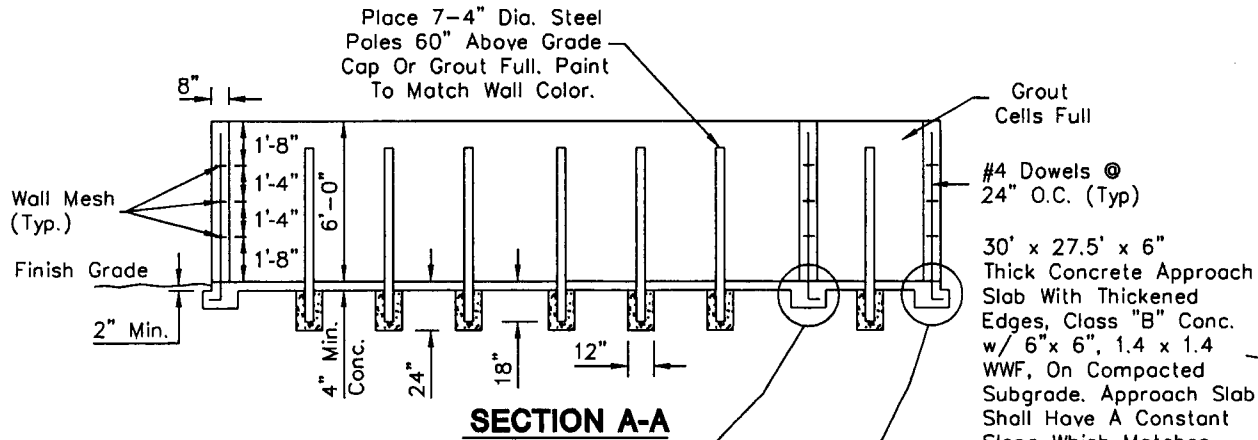

APPROACH SLAB THICKENED EDGE DETAIL

NOTES:

1. Double Enclosure For Angle Pick-Up Similar To COS Det. 2146-1
2. 1/2" Expansion Joint, ASTM D-1751 Per MAG Section 729.

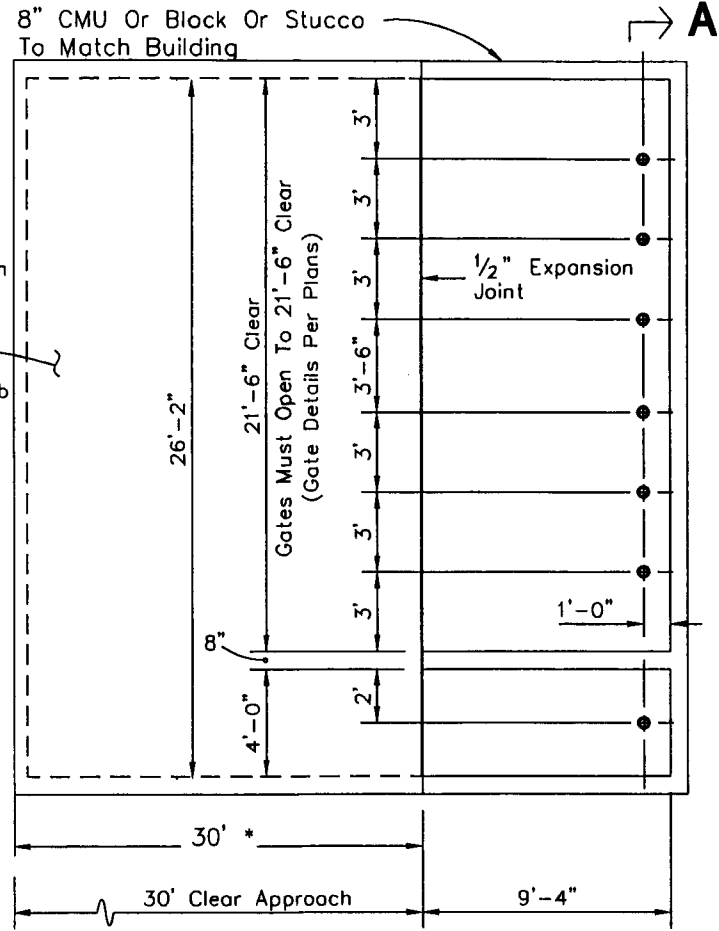

* In locations where a 30' approach slab is not possible, approval from the City of Scottsdale Quality Compliance Division is required.

REVISED 4/12/05

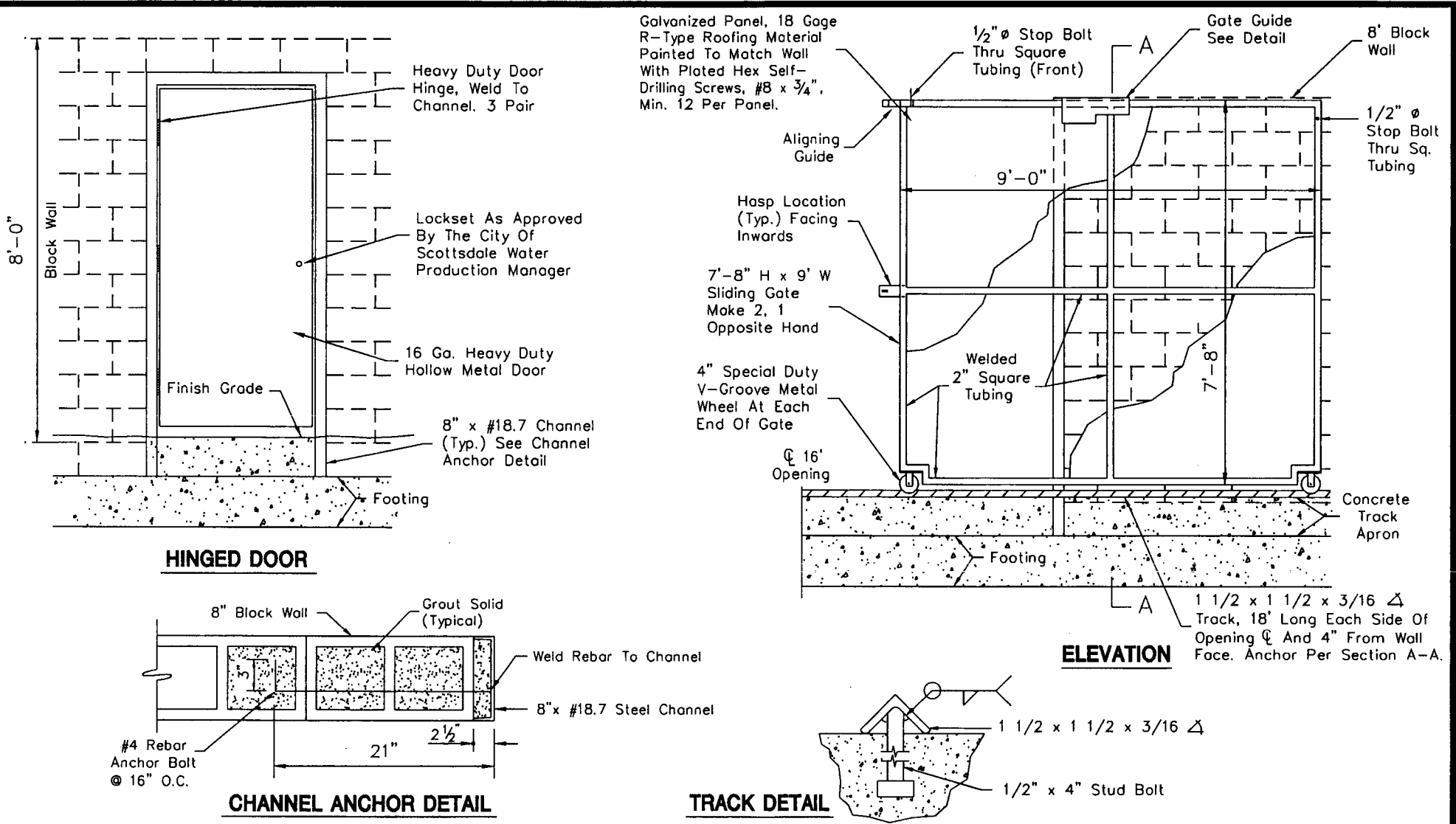

DETAIL NO. 2165-1

City of Scottsdale Standard Details

APPROVED BY: Scottsdale Standards & Specifications Committee

16' SLIDING GATE & HINGED DOOR

DETAIL NO. 2165-1

REVISED 4/12/05

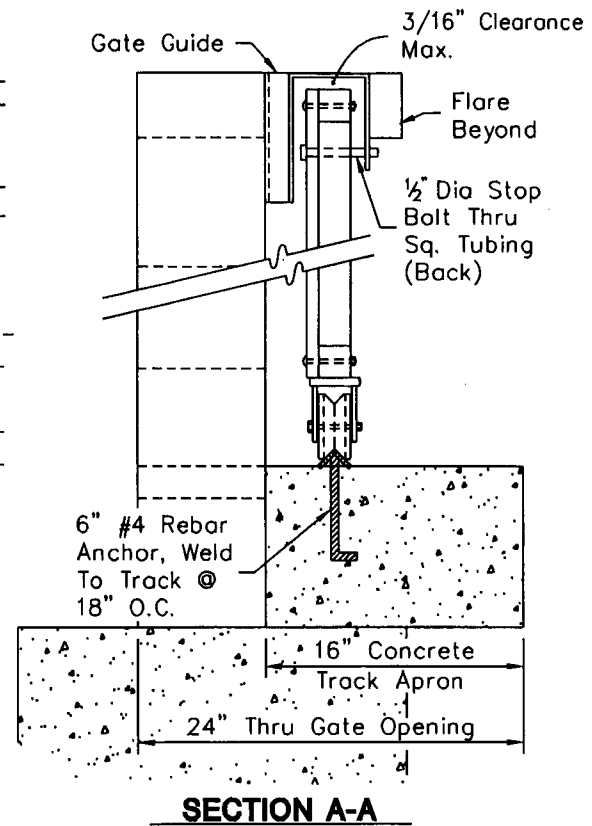
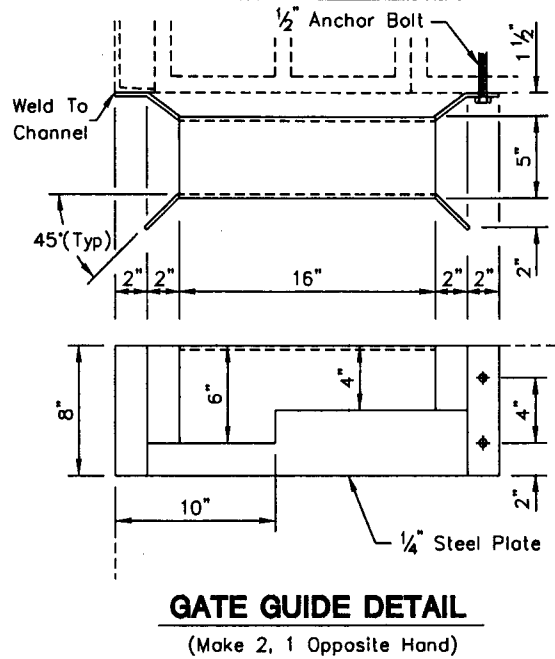
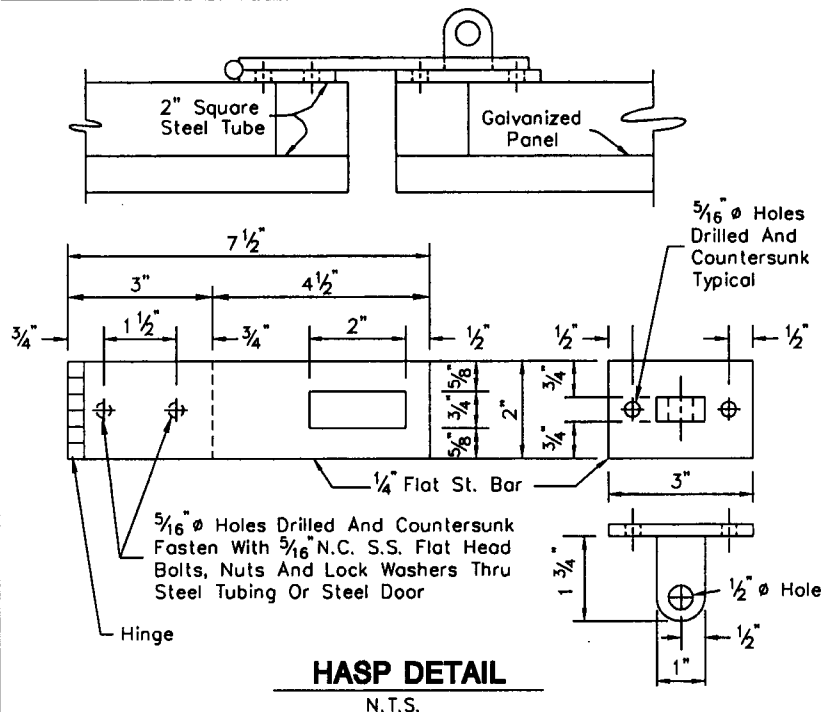

NOTES:

1. Contractor shall prime and paint all metal surfaces. Before application, the color and manufacturer of the paint shall be approved by the City.
2. Prior to painting, all surfaces shall be cleaned free of concrete, mortar, rust, dirt and any other objectionable materials.
3. Apply one (1) primer coat and two (2) exterior alkyd gloss enamel coats to metal.

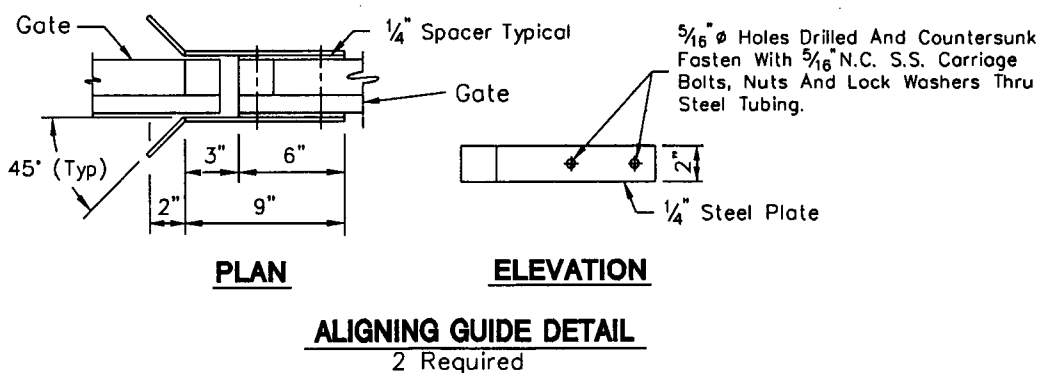

DETAIL NO. 2165-2	City of Scottsdale Standard Details	APPROVED BY: Scottsdale Standards & Specifications Committee	<h1>16' SLIDING GATE</h1>	DETAIL NO. 2165-2
-----------------------------	---	--	---------------------------	-----------------------------

REVISED 7/15/03

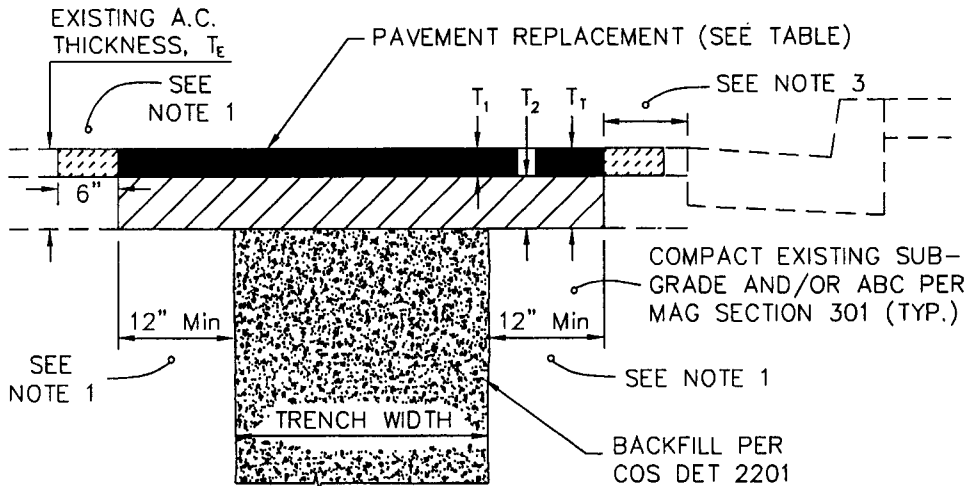

PAVEMENT REPLACEMENT FOR TRENCHES (T-TOP)

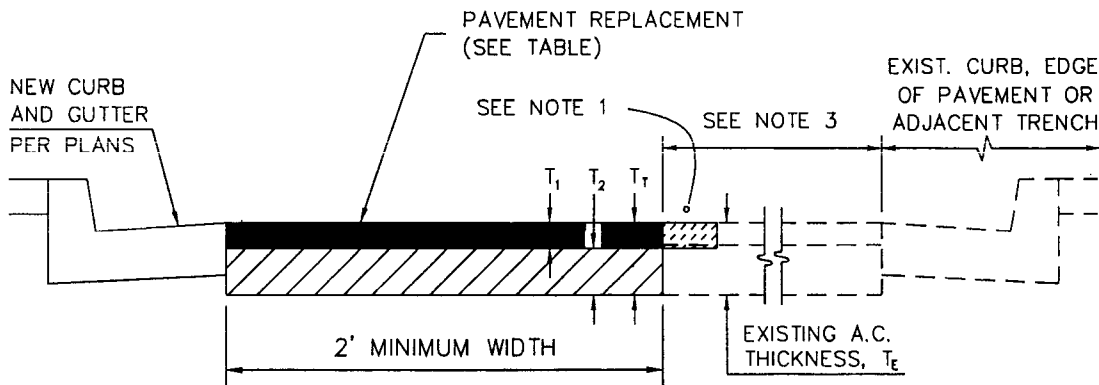

PAVEMENT REPLACEMENT

EXISTING PAVEMENT THICKNESS, T_E	AC PAVEMENT REPLACEMENT TABLE		
	AC SINGLE COURSE OR SURFACE COURSE, T_1	AC BASE COURSE, T_2	TOTAL THICKNESS, T_T
$T_E \leq 3"$	3" MINIMUM	NONE	3" MINIMUM
$T_E > 3"$	2" MINIMUM	2" MINIMUM	T_E (MATCH EXIST)

PAVEMENT REPLACEMENT NOTES

1. "T"-TOP REQUIRED FOR ALL TRENCHES. A.C. SURFACE COURSE REPLACEMENT TO BE MILLED DOUBLE "T" CONFIGURATION AS SPECIFIED BELOW FOR PAVEMENTS 4" AND THICKER.
 - a. FOR PAVEMENT 4 YEARS AND OLDER: INITIAL A.C. REMOVAL TO BE THE MINIMUM WIDTH REQUIRED FOR PROPER TRENCH COMPACTION. SAWCUT & REMOVE 12" OF A.C. MINIMUM ON EACH SIDE OF THE TRENCH FOR THE "T"-TOP AFTER THE BACKFILL MATERIAL IS PLACED. PAVEMENTS 4" AND THICKER, MILL AND REMOVE THE TOP 2" OF THE SURFACE COURSE A MINIMUM OF 6" ON EACH SIDE OF THE T-TOP PRIOR TO PLACEMENT OF THE FINAL SURFACE COURSE LIFT.
 - b. FOR NEW AND OVERLAYED PAVEMENT LESS THAN 4 YEARS OLD AND WHEN ALLOWED UNDER THE PROVISIONS OF SCOTTSDALE REVISED CODE SECTIONS 47-79 AND ALL PAVEMENTS WITH RUBBERIZED SURFACE COURSES: INITIAL A.C. REMOVAL TO BE THE MINIMUM WIDTH REQUIRED FOR PROPER TRENCH COMPACTION. SAWCUT & REMOVE 12" OF A.C. MINIMUM ON EACH SIDE OF THE TRENCH FOR THE "T"-TOP AFTER THE BACKFILL MATERIAL IS PLACED. PAVEMENTS 4" AND THICKER, MILL AND REMOVE THE TOP 2" OF THE SURFACE COURSE EQUALLY ON BOTH SIDES OF THE TRENCH TO A MINIMUM TOTAL WIDTH OF 10 FEET. FOR PAVEMENTS LESS THAN 4" THICK SAWCUT, REMOVE AND REPLACE THE ENTIRE PAVEMENT SURFACE TO A MINIMUM TOTAL WIDTH OF 10 FEET, AS DIRECTED BY THE ENGINEER.
 - c. FOR DEEP PAVEMENT STRUCTURES REQUIRING TWO OR MORE PAVEMENT BASE LIFTS: INITIAL A.C. REMOVAL TO BE THE MINIMUM WIDTH REQUIRED FOR PROPER TRENCH COMPACTION. SAWCUT, REMOVE AND REPLACE A.C. ON BOTH SIDES OF THE TRENCH AS NECESSARY TO ACCOMMODATE A RIDE ON TYPE VIBRATORY ROLLER COMPACTOR FOR PLACEMENT OF THE A.C. BASE COURSE LIFTS, MATCH EXISTING A.C. DEPTH. MILL AND REMOVE THE TOP 2" OF THE SURFACE COURSE EQUALLY ON BOTH SIDES OF THE TRENCH TO A MINIMUM TOTAL WIDTH OF 10 FEET.
2. ASPHALT CONCRETE SHALL BE IN ACCORDANCE WITH THE REQUIREMENTS OF MAG SECTION 321.
3. IF PAVEMENT REMNANT IS LESS THAN 36", REMOVE AND REPLACE PAVEMENT AS PER THIS DETAIL.
4. AGGREGATE BASE COURSE PER MAG SECTION 702 SHALL BE PROVIDED TO MATCH EXISTING ABC THICKNESS IN ADJACENT ROADWAY.
5. REFER TO COS SUPPLEMENTAL SPECIFICATIONS, SECTION 336.2.4 FOR PAVEMENT SMOOTHNESS REQUIREMENTS.

DETAIL NO.
2200

City of Scottsdale
Standard Details

APPROVED BY:
Scottsdale Standards & Specifications Committee

PAVEMENT REPLACEMENT

DETAIL NO.
2200

REVISED 4/30/04

BACKFILL DETAILS

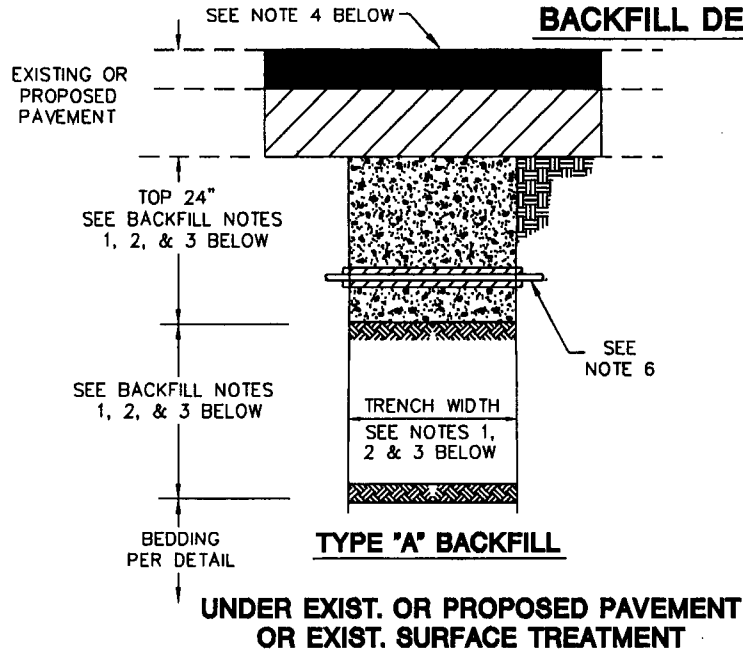

BACKFILL NOTES

1. TRENCHES 24" IN WIDTH OR LESS - 1/2 SACK CSLM, MAG 728, FULL DEPTH OF BACKFILL BOTTOM OF ABC LAYER IN PAVEMENT STRUCTURE OR 6" BELOW PAVEMENT IN FULL DEPTH PAVEMENT STRUCTURES. CONSTRUCT PAVEMENT STRUCTURE TO MATCH EXISTING AND IN ACCORDANCE WITH COS DETAIL 2200.
2. TRENCHES 24" TO 6' IN WIDTH - 1/2 SACK CSLM AS DESCRIBED IN NOTE 1 ABOVE WITHIN THE TOP 24" OF THE TRENCH; MAG 601.4.3 FOR BALANCE OF BACKFILL.
3. TRENCHES OVER 6' IN WIDTH - MAG 601.4.3 FULL DEPTH OF BACKFILL.
4. TREAT ENTIRE DISTURBED SURFACE OF UNPAVED ALLEYS WITH LIGNIN-BASED DUST PALLATIVE, MAG 792, 1:1 DILUTION RATIO, 0.50 GAL/SY APPLICATION RATE.
5. CSLM SHALL NOT BE USED FOR WATER OR SEWER PIPE BEDDING. SEE BEDDING DETAIL.
6. EXPOSED COPPER OR POLYETHYLENE WATER PIPES IN SIZES 1" TO 2" SHALL BE WRAPPED WITH 1/2" WIDE BLACK INSULATION BEFORE PLACING CSLM.
7. RECYCLED ASPHALT SHALL NOT BE USED FOR BACKFILL.

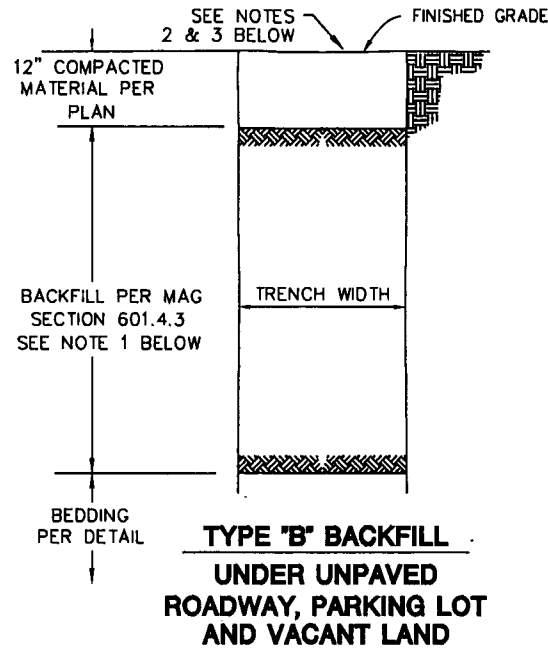

BACKFILL NOTES

1. MAG 601.4.3 FULL DEPTH OF BACKFILL
2. ENTIRE DISTURBED EXISTING SURFACE TO BE RESTORED WITH A LIKE MATERIAL
3. TREAT ENTIRE DISTURBED SURFACE WITH LIGNIN-BASED DUST PALLATIVE, MAG 792, 1:1 DILUTION RATIO, 0.50 GAL/SY APPLICATION RATE.
4. RECYCLED ASPHALT SHALL NOT BE USED FOR BACKFILL.

BEDDING DETAILS

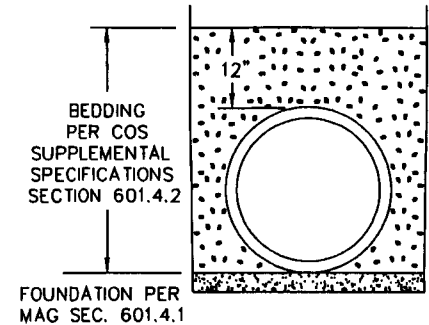
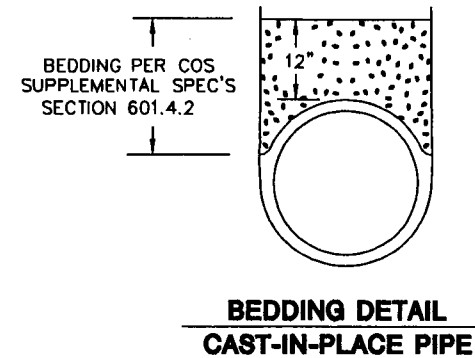

NOTES:

1. FOR HDPE PIPE - SEE COS SUPPLEMENTAL SPECIFICATIONS SECTION 603.4.2
2. RECYCLED ASPHALT SHALL NOT BE USED FOR BEDDING OR FOUNDATION MATERIAL.

DETAIL NO.
2201

City of Scottsdale
Standard Details

APPROVED BY:
Scottsdale Standards & Specifications Committee

TRENCH BEDDING & BACKFILL

DETAIL NO.
2201

REVISED: 4/25/02

NOTES:

1. The contractor shall provide adequate overlap of plate on asphalt to assure no slippage of plate and no collapsing of trench.
2. "Posted Speed" does not include temporary construction signing.

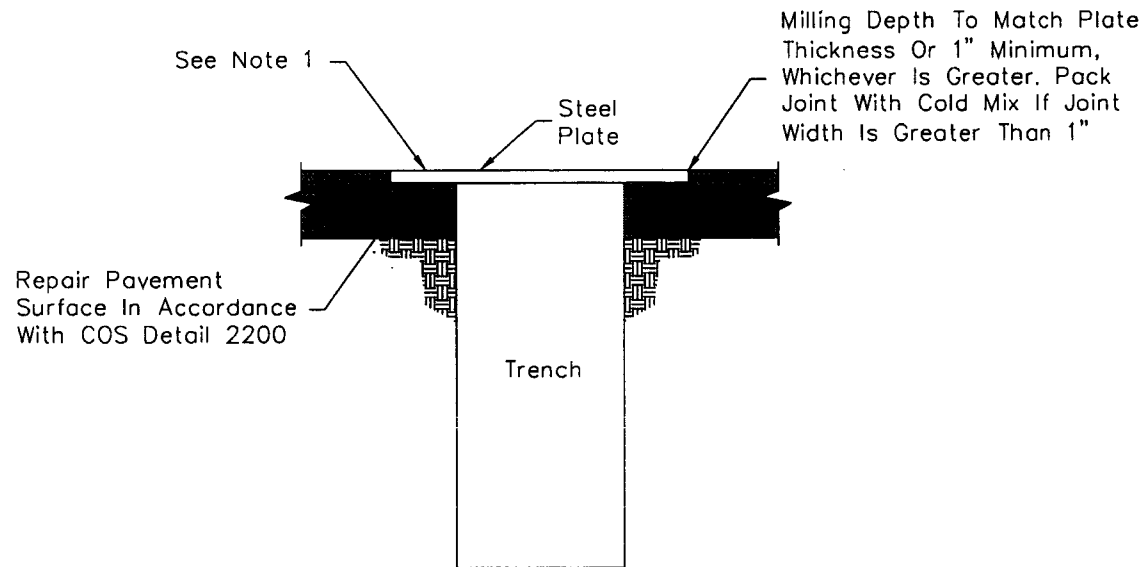

TYPE 'A' PLATING

CITY POSTED SPEEDS OF 35 MPH AND GREATER OR BUS & TRUCK ROUTE

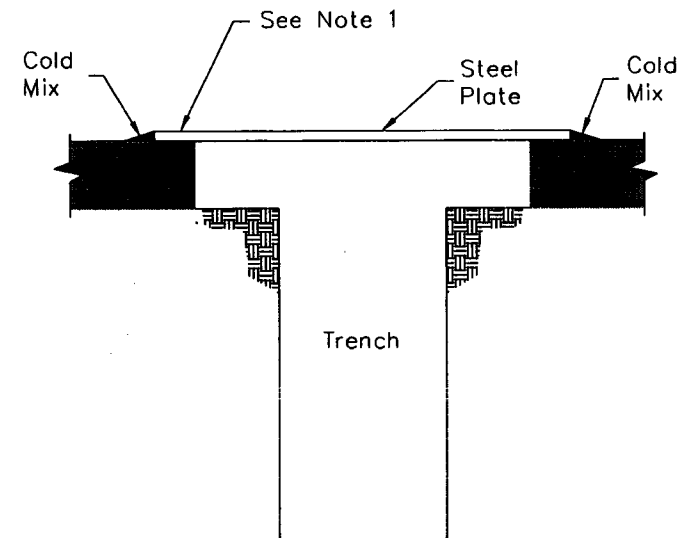

TYPE 'B' PLATING

CITY POSTED SPEEDS UNDER 35 MPH

DETAIL NO.
2202

**City of Scottsdale
Standard Details**

APPROVED BY:
**Scottsdale Standards &
Specifications Committee**

TRENCH PLATING

DETAIL NO.
2202

REVISED: 3/28/02

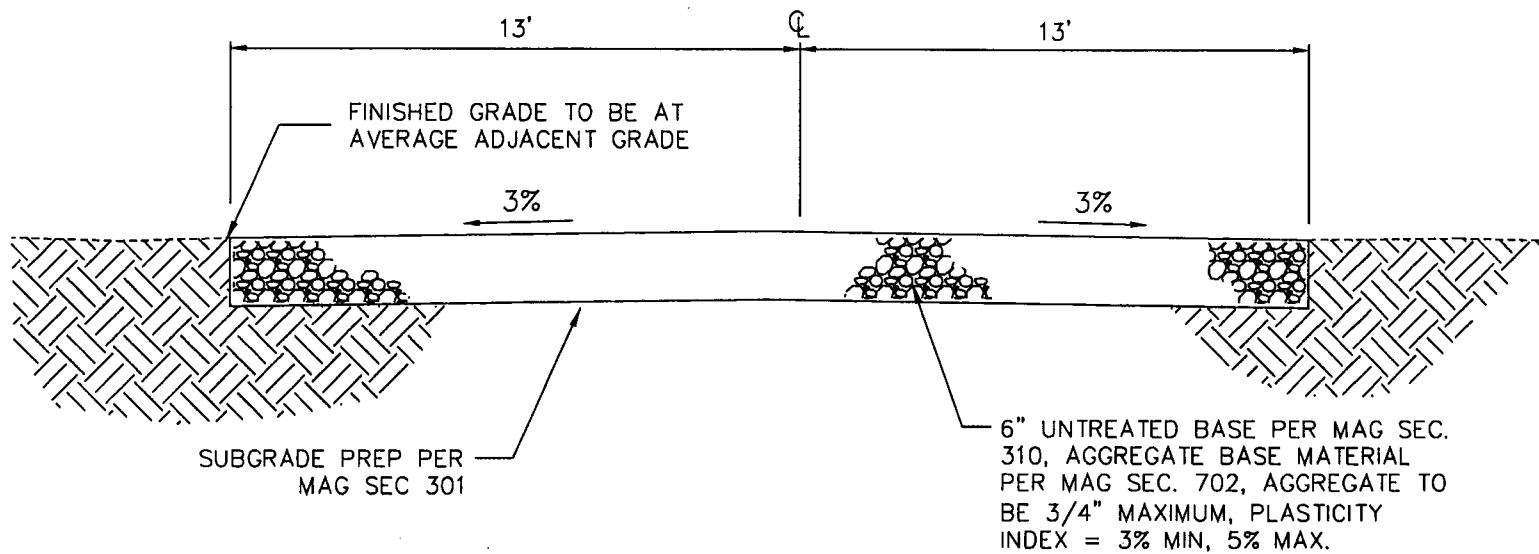

UNPAVED ROAD DETAIL

DETAIL NO.
2207

**City of Scottsdale
Standard Details**

APPROVED BY:
**Scottsdale Standards &
Specifications Committee**

RESIDENTIAL UNPAVED ROAD

DETAIL NO.
2207

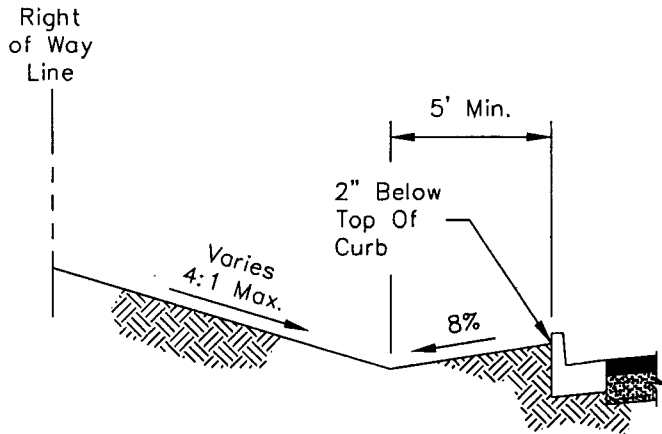

NO SIDEWALK

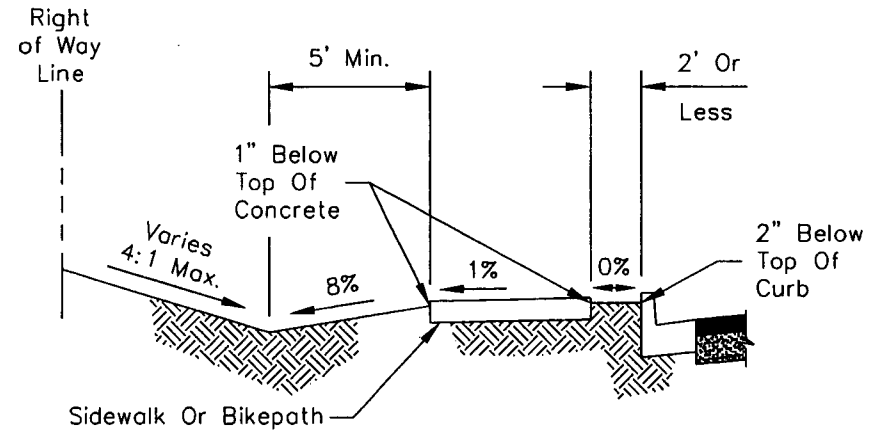

SIDEWALK LESS THAN 2' BEHIND CURB

NOTE:

Runoff Shall Not Be Directed To Cross Over The Top Of A Sidewalk.

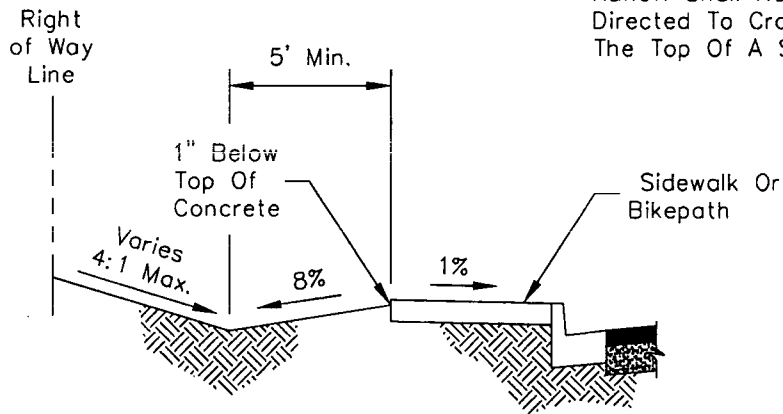

SIDEWALK AT BACK OF CURB

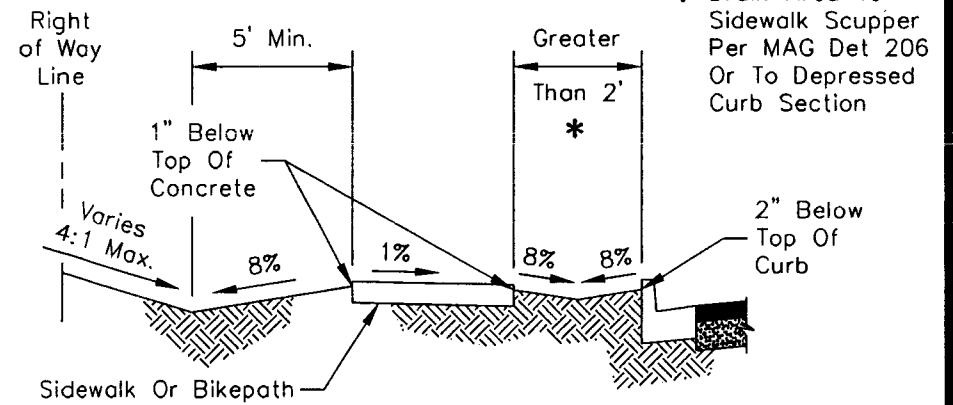

SIDEWALK MORE THAN 2' BEHIND CURB

* Drain Area To Sidewalk Scupper Per MAG Det 206 Or To Depressed Curb Section

DETAIL NO.
2210

**City of Scottsdale
Standard Details**

APPROVED BY:
**Scottsdale Standards &
Specifications Committee**

GRADING BEHIND THE CURB

DETAIL NO.
2210

REVISED 4/7/00

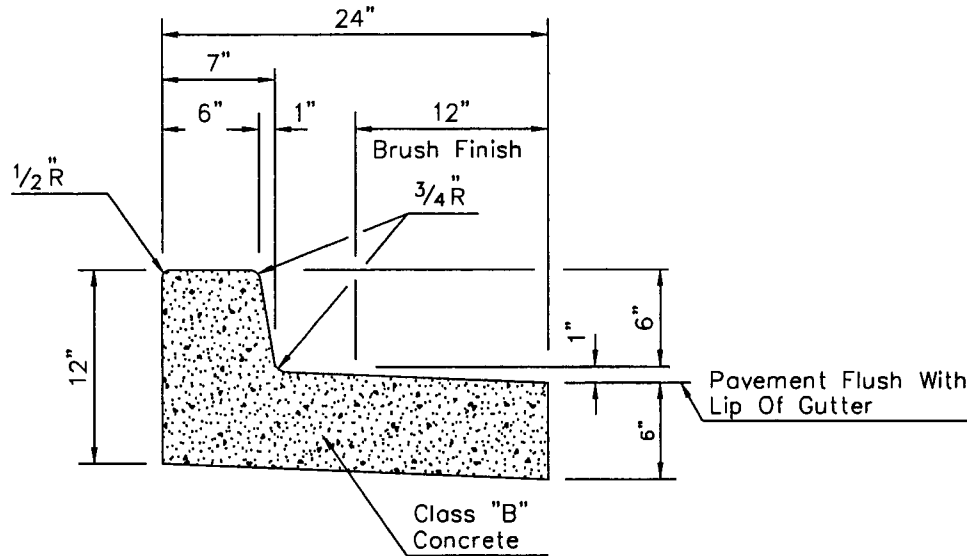

VERTICAL CURB & GUTTER WITH DEPRESSED LIP

TYPE 'A'

NOTES

1. All exposed surfaces to be trowel finished except as shown. See M.A.G. Section 340.
2. Contraction joint spacing 10' maximum.
3. Construct curb and install 1/2" mastic expansion joints, A.S.T.M. D-1751, per M.A.G. Sec. 340 & 729 and COS Sec. 340.
4. Colored concrete shall be colored integrally.

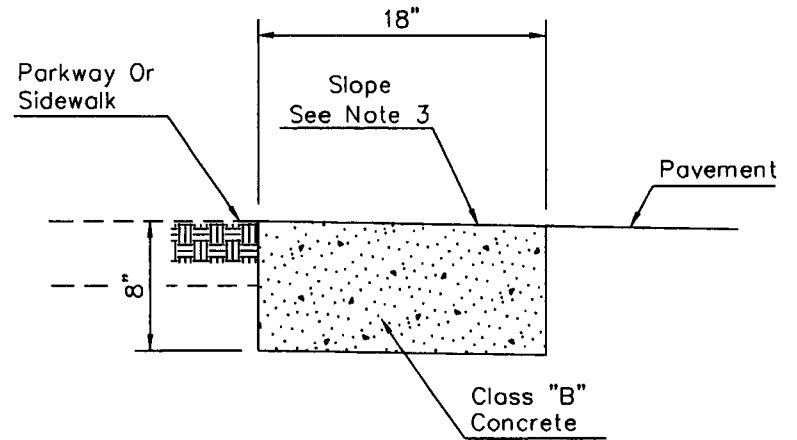

RIBBON CURB

TYPE 'B'

NOTES

1. Construct curb and install 1/2" mastic expansion joints, A.S.T.M. D-1751, per M.A.G. Sec. 340 & 729 and COS Sec 340.
2. Broom finish all surfaces.
3. Ribbon curb may slope towards pavement or parkway. Match cross slope of road unless indicated otherwise on plans.
4. Contraction joint spacing 10' maximum.
5. Colored concrete shall be colored integrally.

DETAIL NO. **2220** **City of Scottsdale Standard Details**

APPROVED BY: **Scottsdale Standards & Specifications Committee**

CURB AND GUTTER - TYPES A & B

DETAIL NO. **2220**

MEDIAN NOSE CURVE DATA

CURVE	RADIUS*	LENGTH	TANGENT	CHORD	DELTA
C3	59.5'	19.06'	9.61'	18.97'	18°20'59"
C4	0.50'	1.41'	3.10'	0.99'	161°39'01"

 Paint Top And Front Of Curb With ReflectORIZED Yellow Traffic Paint And Add Type "D" Yellow Two Way Reflective Raised Pavement Markers to Median Nose, Spaced at 5-feet.

Note: Extend Median Treatment to a Width of 6 feet or as shown on the plans.

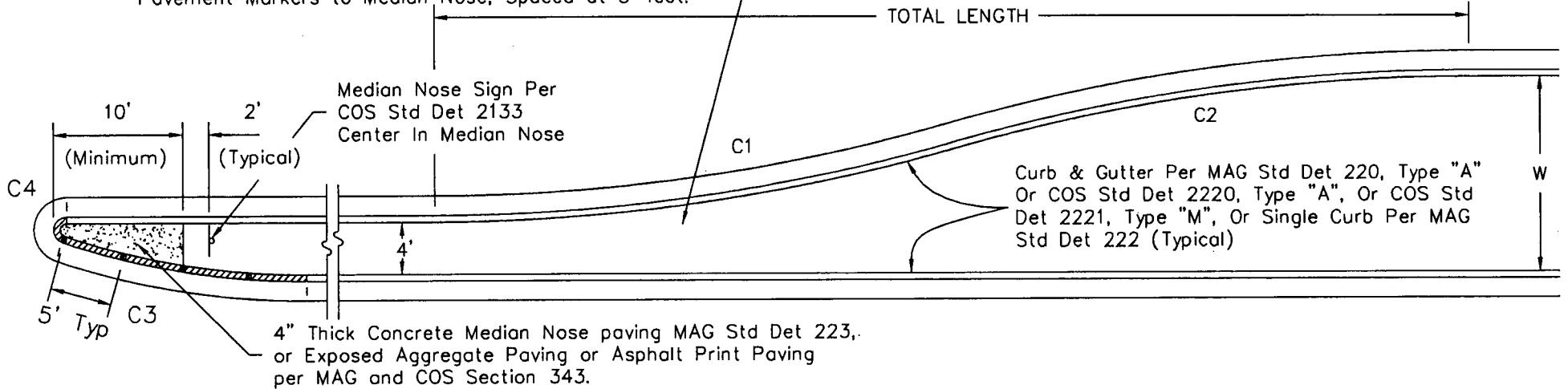

REVISED 3/28/02

STREET CLASSIFICATION	TYPE A		TYPE B		TYPE C		TYPE D		TYPE E		TYPE F	
	COLLECTOR STREET		MINOR ARTERIAL		MAJOR ARTERIAL		DUAL LEFT TURN LANES		MINOR ARTERIAL		MAJOR ARTERIAL	
TOTAL LENGTH	80.49'		98.89'		114.36'		164.53'		103.23'		153.62'	
MEDIAN WIDTH, W	15'		15'		15'		27'		16'		24'	
CURVE NUMBER	C1	C2	C1	C2	C1	C2	C1	C2	C1	C2	C1	C2
RADIUS *	150.00'	150.00'	150.00'	300.00'	300.00'	300.00'	300.00'	300.00'	150.00'	300.00'	300.00'	300.00'
DELTA	15°33'49"	15°33'49"	12°41'40"	12°41'40"	10°59'17"	10°59'17"	15°54'56"	15°54'56"	13°15'41"	13°15'41"	14°50'06"	14°50'06"
LENGTH	40.75'	40.75'	33.23'	66.47'	57.53'	57.53'	83.33'	83.33'	34.72'	69.44'	77.68'	77.68'
TANGENT	20.50'	20.50'	16.69'	33.37'	28.86'	28.86'	41.94'	41.94'	17.44'	34.87'	39.06'	39.06'
CHORD	40.62'	40.62'	33.17'	66.33'	57.45'	57.45'	83.07'	83.07'	34.64'	69.28'	83.07'	83.07'

NOTE: Curve Data Shown Is For Streets On Linear Alignments Only.

* ALL RADII AND DIMENSIONS TO BACK OF CURB

DETAIL NO. 2225	City of Scottsdale Standard Details	APPROVED BY: Scottsdale Standards & Specifications Committee	MEDIAN NOSE & REVERSE CURVE DETAILS	DETAIL NO. 2225
---------------------------	--	--	--	---------------------------

REVISED 3/28/02

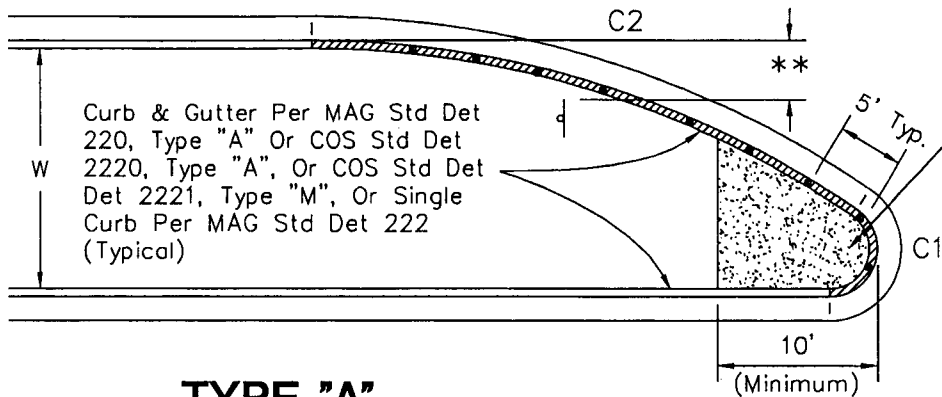

TYPE "A"

 Paint Top And Front Of Curb With Reflectorized Yellow Traffic Paint And Add Type "D" Yellow Reflective Raised Pavement Markers to Median Nose, Spaced at 5-feet.

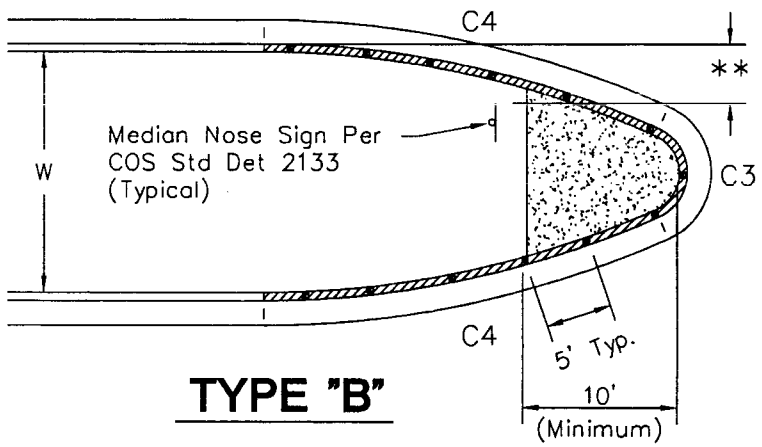

TYPE "B"

4" Thick Concrete Median Nose Paving
MAG Std Det 223, or Exposed Aggregate Paving or Asphalt Print Paving per MAG and COS Section 343 (Typical)

* ALL RADII AND DIMENSIONS TO BACK OF CURB

** OFFSET TO BE NO MORE THAN 3' FROM FACE OF CURB AT TANGENT TO EDGE OF SIGN

* CURVE DATA - W=15'

CURVE	RADIUS	LENGTH	TANGENT	CHORD	DELTA
C1	2.50'	6.35'	8.06'	4.78'	145°32'39"
C2	59.50'	35.78'	18.45'	35.24'	34°27'21"
C3	2.50'	5.74'	5.57'	4.56'	131°38'42"
C4	59.50'	25.11'	12.74'	24.92'	24°10'39"

* CURVE DATA - W=16'

CURVE	RADIUS	LENGTH	TANGENT	CHORD	DELTA
C1	2.50'	6.27'	7.65'	4.75'	143°48'20"
C2	59.50'	37.59'	19.44'	36.97'	36°11'40"
C3	2.50'	5.64'	5.27'	4.52'	129°14'46"
C4	59.50'	26.35'	13.40'	26.14'	25°22'37"

* CURVE DATA - W=24'

CURVE	RADIUS	LENGTH	TANGENT	CHORD	DELTA
C1	2.50'	5.75'	5.59'	4.56'	131°48'37"
C2	59.50'	50.04'	26.61'	48.58'	48°11'23"
C3	2.50'	4.93'	3.77'	4.17'	112°53'08"
C4	59.50'	34.85'	17.94'	34.35'	33°33'26"

DETAIL NO.
2226

**City of Scottsdale
Standard Details**

APPROVED BY:
**Scottsdale Standards &
Specifications Committee**

MEDIAN NOSE DETAILS

DETAIL NO.
2226

REVISED 2/22/99

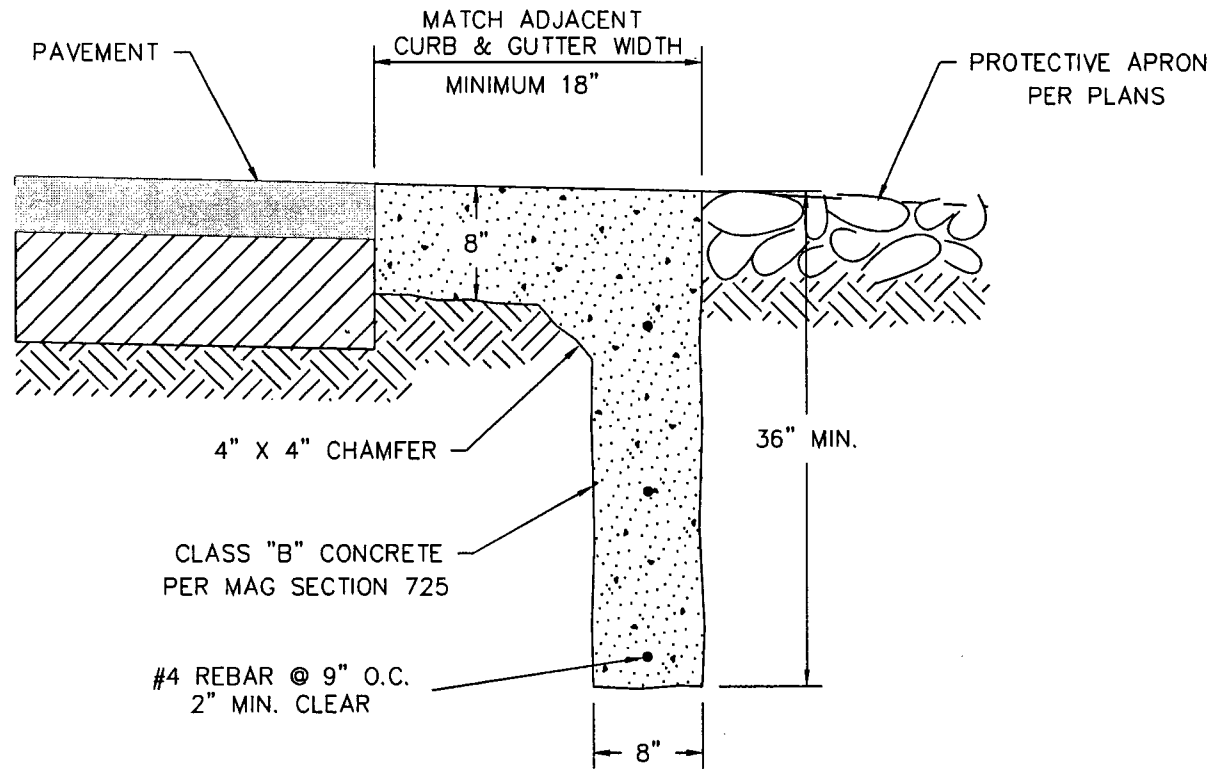

NOTE: Form The Top 8"
Of Cut-Off Wall

DETAIL NO.
2228

City of Scottsdale
Standard Details

APPROVED BY:
**Scottsdale Standards &
Specifications Committee**

CUT-OFF WALL

DETAIL NO.
2228

REVISED 4/18/05

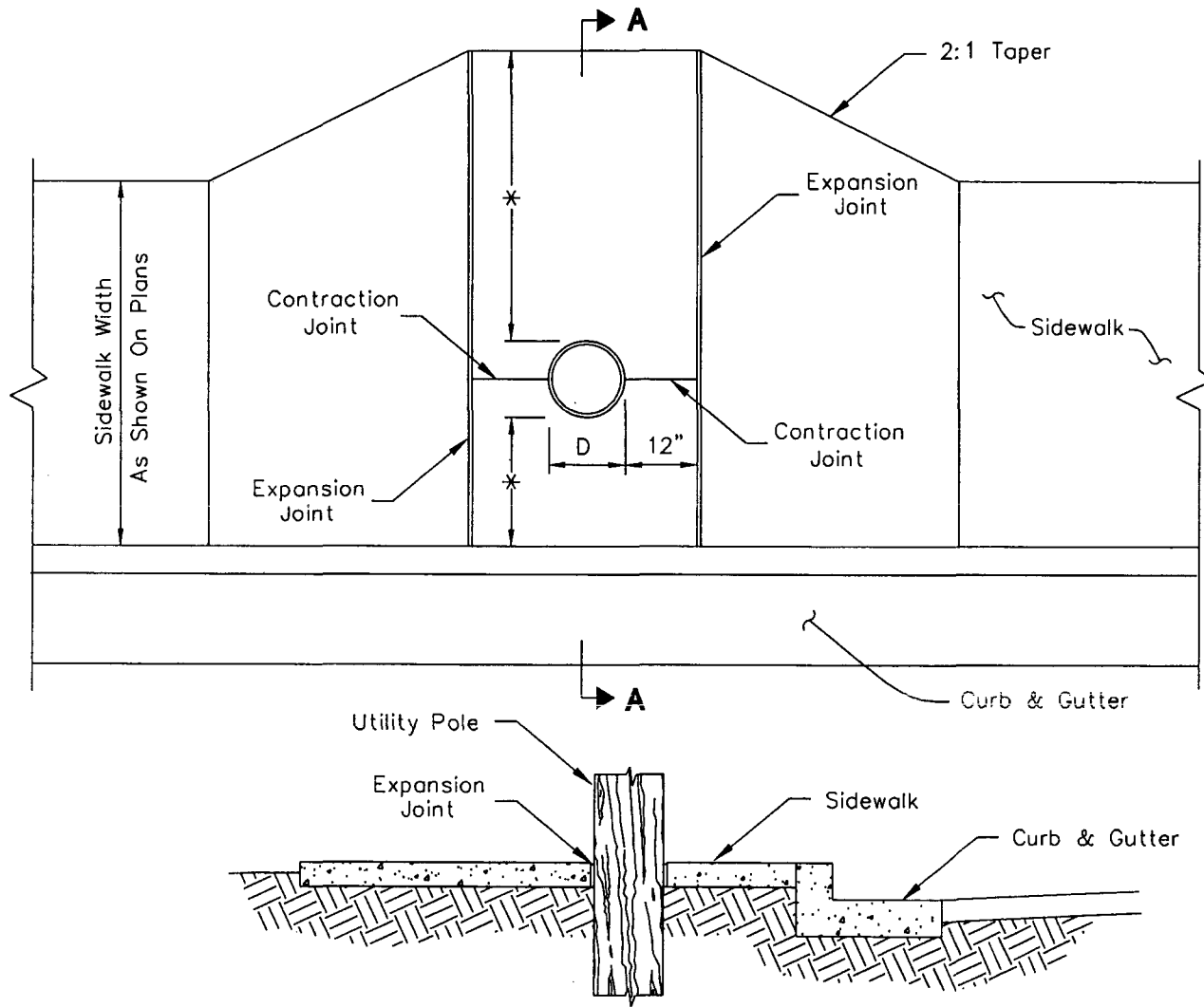

NOTES

Install expansion joint around wood pole.

Install expansion joint at sidewalk 1/4" lower than sidewalk

* Maintain 48" clear on one side of utility pole unless otherwise approved by City staff.

D = Pole Diameter
Range: 12"-17"

SECTION A-A

DETAIL NO.
2230

**City of Scottsdale
Standard Details**

APPROVED BY:
**Scottsdale Standards &
Specifications Committee**

SIDEWALK CUTOUT FOR UTILITY POLES

DETAIL NO.
2230

REVISED 5/25/05

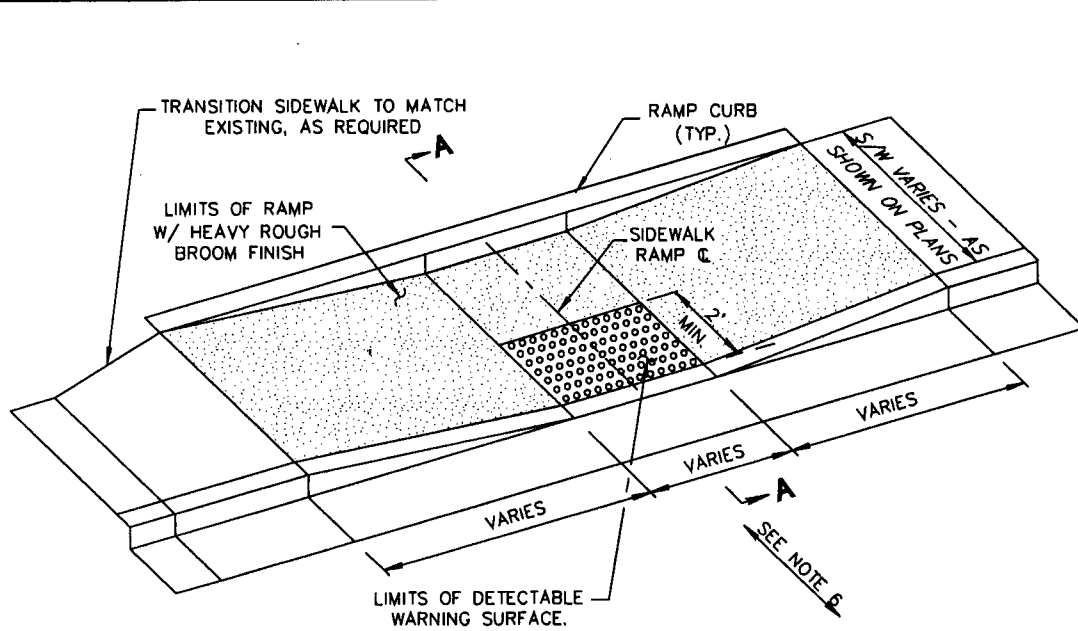

NOTES

1. DETECTABLE WARNING SHALL CONSIST OF RAISED TRUNCATED DOMES MANUFACTURED BY "COTE-L INDUSTRIES, INC." CALLED "SAFTI-TRAX", WITH POLYURETHANE COATING "DURABAK", OR APPROVED EQUAL, APPLIED ON SMOOTH (NON-GROOVED) CLEAN CONCRETE RAMP, AND SHALL CONFORM TO THE DETAILS IN THE PLANS AND IN ACCORDANCE WITH MANUFACTURER'S SPECIFICATIONS AND INSTALLATION INSTRUCTIONS.
2. ALL DETECTABLE WARNING AREAS SHALL START AT BACK OF CURB, BE 24 INCHES IN DEPTH AND COVER THE COMPLETE WIDTH OF THE RAMP AREA 48 INCHES MIN..
3. 70% VISUAL CONTRAST IS REQUIRED. THE COLOR SHALL BE AN INTEGRAL PART OF THE DETECTABLE WARNING MATERIAL, AS SPECIFIED ON THE PLANS. COLOR TO BE DETERMINED BY THE CITY STAFF, SAFETY YELLOW IS THE DEFAULT COLOR.
4. THE SMOOTH AND CLEAN CONCRETE UNDER DETECTABLE WARNING DEVICE AREA SHALL BE INCLUDED IN THE COST OF THE CONCRETE CURB RAMP. THE COST OF FURNISHING AND INSTALLING THE DETECTABLE WARNING DEVICE SHALL BE INCLUDED SEPARATELY AS "DETECTABLE WARNING DEVICE" PER SQUARE FOOT OR AS OUTLINED IN THE SPECIFICATIONS.
5. DETECTABLE WARNING SURFACE:
APPLIED A COATING OF "DURABAK" SLIP-RESISTANT POLYURETHANE COATING TO THE SMOOTH, CLEAN CONCRETE SURFACE. ON TOP OF THE POLYURETHANE COATING APPLY TRUNCATED DOMES FROM A "SAFTI-TRAX" CONTACT SHEET. ON TOP OF THE TRUNCATED DOMES AND INITIAL POLYURETHANE COATING PLACE THREE ADDITIONAL COATS OF "DURABAK" POLYURETHANE COATING. COLOR TO BE DETERMINED BY CITY STAFF OR AS SPECIFIED ON THE PLANS. SAFETY YELLOW IS A DEFAULT COLOR.
6. ALL RAMPS AND DETECTABLE WARNING SHALL BE ALIGNED IN THE DIRECTION OF PEDESTRIAN TRAVEL AND DIRECTED TOWARD RAMP ON THE OPPOSITE SIDE OF STREET.

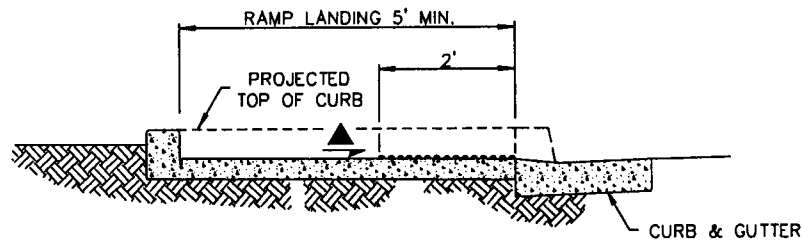

SECTION A-A

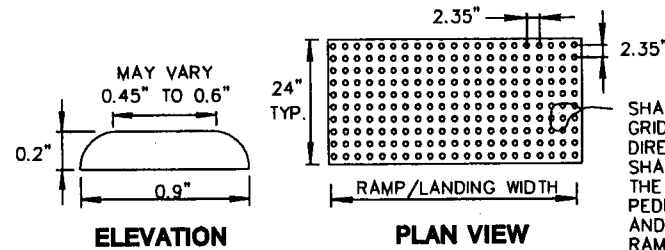

TRUNCATED DOME DETECTABLE WARNING

SHALL BE A SQUARE GRID, EQUAL IN BOTH DIRECTIONS. DOMES SHALL BE ALIGNED IN THE DIRECTION OF PEDESTRIAN TRAVEL AND DIRECTED TOWARD RAMP ON OPPOSITE SIDE OF STREET.

DETAIL NO.
2231

**City of Scottsdale
Standard Details**

APPROVED BY:
**Scottsdale Standards &
Specifications Committee**

DETECTABLE WARNING SURFACE

DETAIL NO.
2231

REVISED 5/25/05

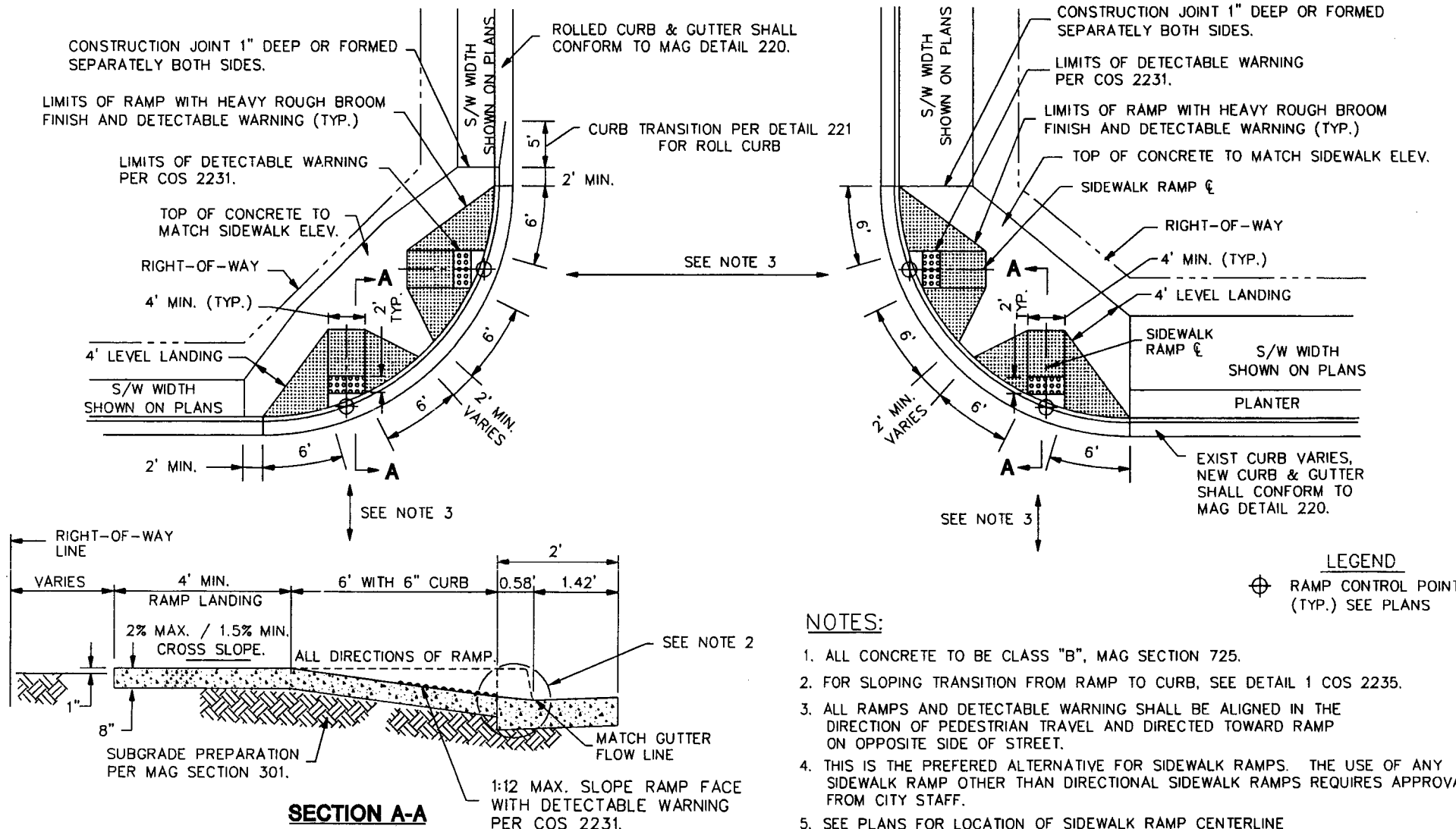

DETAIL NO. 2232

City of Scottsdale
Standard Details

APPROVED BY:
Scottsdale Standards & Specifications Committee

DIRECTIONAL SIDEWALK RAMPS

DETAIL NO. 2232



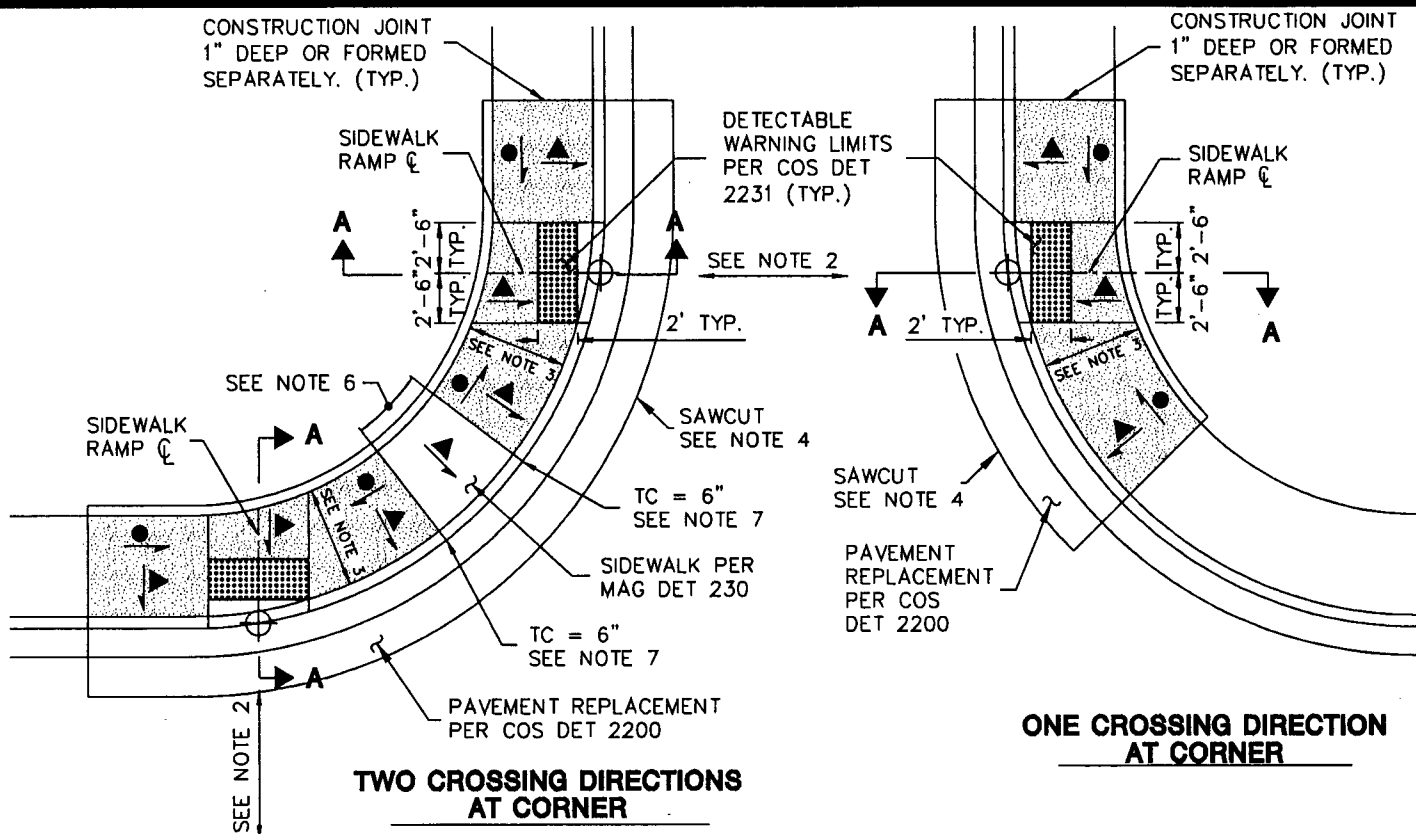

REVISED 5/25/05

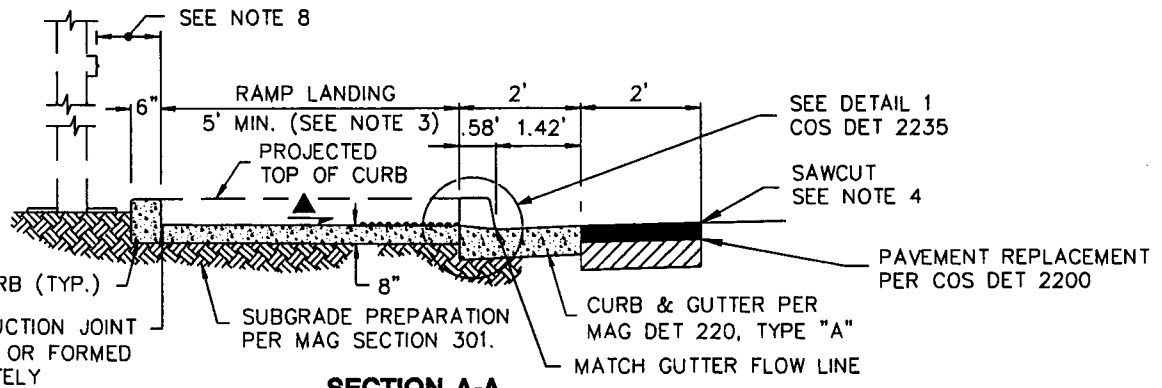

- NOTES:**
1. ALL CONCRETE TO BE CLASS "B", MAG SECTION 725.
 2. ALL RAMPS AND DETECTABLE WARNING SHALL BE ALIGNED IN THE DIRECTION OF PEDESTRIAN TRAVEL AND DIRECTED TOWARD RAMP ON THE OPPOSITE SIDE OF STREET.
 3. 5' MINIMUM MEASURED RADIALLY FROM BACK OF CURB TO THE FACE OF RAMP CURB.
 4. WHEN A CONCRETE APRON EXISTS THE SAWCUT MAY BE MADE IN THE APRON 2' FROM BACK OF EXISTING CURB.
 5. SEE PLANS FOR LOCATION OF SIDEWALK RAMP CENTERLINE.
 6. MINIMUM 4' LONG LEVEL AREA REQUIRED BETWEEN RAMPS.
 7. CURB HEIGHT MAY BE DECREASED TO 4" FOR SPACE LIMITED AREAS PROVIDED THE RAMP SLOPE IS A MAXIMUM 12:1 AND THE MINIMUM 4' LONG LEVEL AREA BETWEEN RAMPS IS MAINTAINED.
 8. PROVIDE 10" MAXIMUM TO FACE OF ANY EXISTING PEDESTRIAN PUSH BUTTON. RAMP CURB AND LANDING MAY NEED TO BE EXTENDED AROUND POLE TO PROVIDE ACCESS TO PUSH BUTTON.
 9. EACH RAMP RETROFIT REQUIRES A SITE SPECIFIC ASSESSMENT AND FIELD REVIEW BY THE DESIGN ENGINEER TO ENSURE FUNCTIONAL DESIGN.



LEGEND

-  RAMP CONTROL POINT (TYP.) SEE PLANS
-  12:1 MAXIMUM SLOPE, 15:1 DESIRED SLOPE
-  2% MAXIMUM SLOPE, 1.5% MINIMUM SLOPE
-  SIDEWALK RAMP PAYMENT LIMITS AND HEAVY ROUGH BROOM FINISH LIMITS



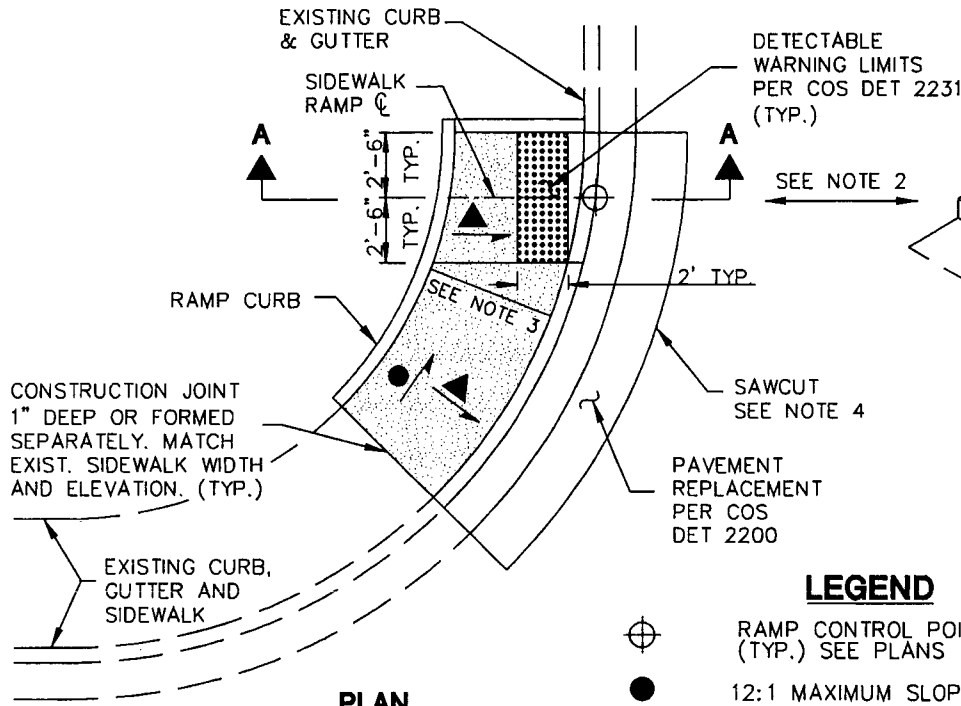

SECTION A-A

REVISED 5/25/05



PLAN

LEGEND

-  RAMP CONTROL POINT (TYP.) SEE PLANS
-  12:1 MAXIMUM SLOPE, 15:1 DESIRED SLOPE
-  2% MAXIMUM SLOPE, 1.5% MINIMUM SLOPE
-  SIDEWALK RAMP PAYMENT LIMITS AND HEAVY ROUGH BROOM FINISH LIMITS

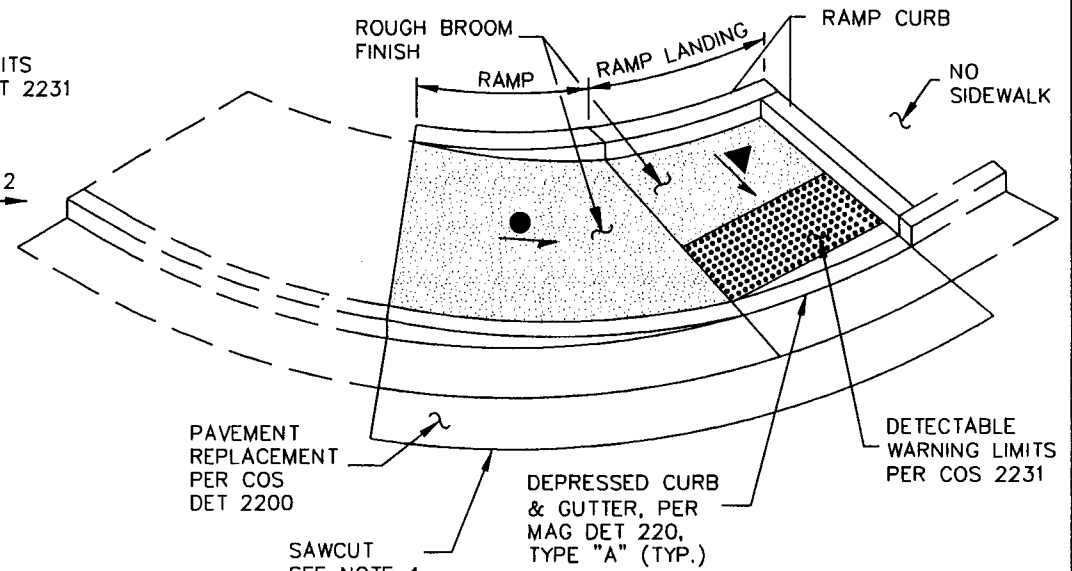

PERSPECTIVE

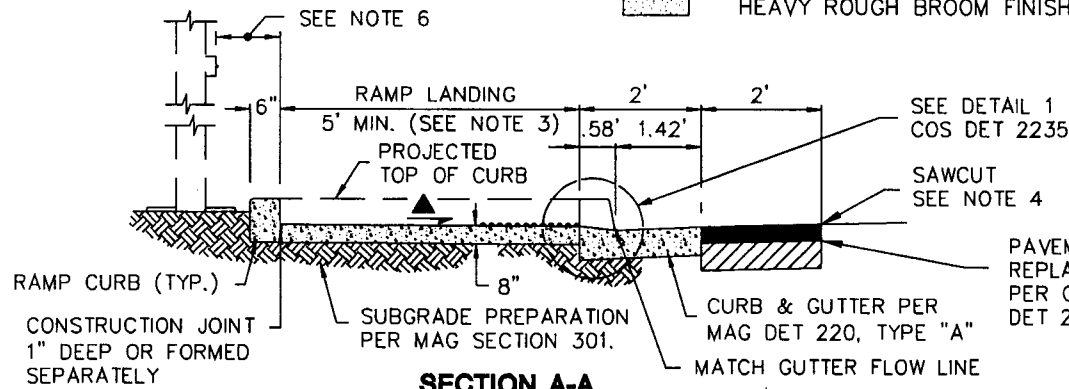

SECTION A-A

NOTES:

1. ALL CONCRETE TO BE CLASS "B", MAG SECTION 725.
2. ALL RAMPS AND DETECTABLE WARNING SHALL BE ALIGNED IN THE DIRECTION OF PEDESTRIAN TRAVEL AND DIRECTED TOWARD RAMP ON THE OPPOSITE SIDE OF STREET.
3. 5' MINIMUM MEASURED RADIALLY FROM BACK OF CURB TO FACE OF RAMP CURB.
4. WHEN A CONCRETE APRON EXISTS THE SAWCUT MAY BE MADE IN THE APRON 2' FROM BACK OF EXISTING CURB.
5. SEE PLANS FOR LOCATION OF SIDEWALK RAMP CENTER LINE.
6. PROVIDE 10" MAXIMUM TO FACE OF ANY EXISTING PEDESTRIAN PUSH BUTTON. RAMP CURB AND LANDING MAY NEED TO BE EXTENDED AROUND POLE TO PROVIDE ACCESS TO PUSH BUTTON.
7. THIS SIDEWALK RAMP DETAIL IS FOR RETROFITTING ONLY AND IS NOT TO BE USED FOR NEW CONSTRUCTION.
9. EACH RAMP RETROFIT REQUIRES A SITE SPECIFIC ASSESSMENT AND FIELD REVIEW BY THE DESIGN ENGINEER TO ENSURE FUNCTIONAL DESIGN.

DETAIL NO.

2233-2

**City of Scottsdale
Standard Details**

APPROVED BY:

**Scottsdale Standards &
Specifications Committee**

DIRECTIONAL SIDEWALK RAMP RETROFIT - TYPE B

DETAIL NO.

2233-2

REVISED 5/25/05

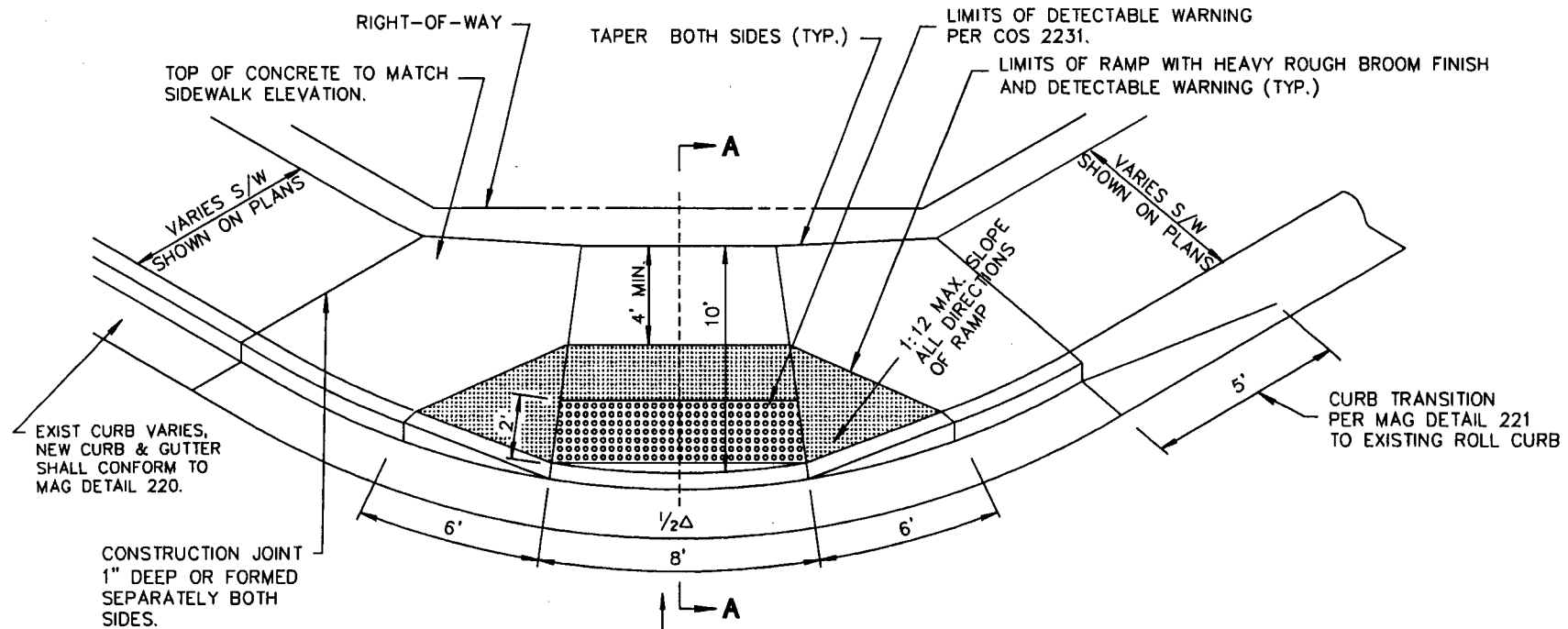

SEE NOTE 3

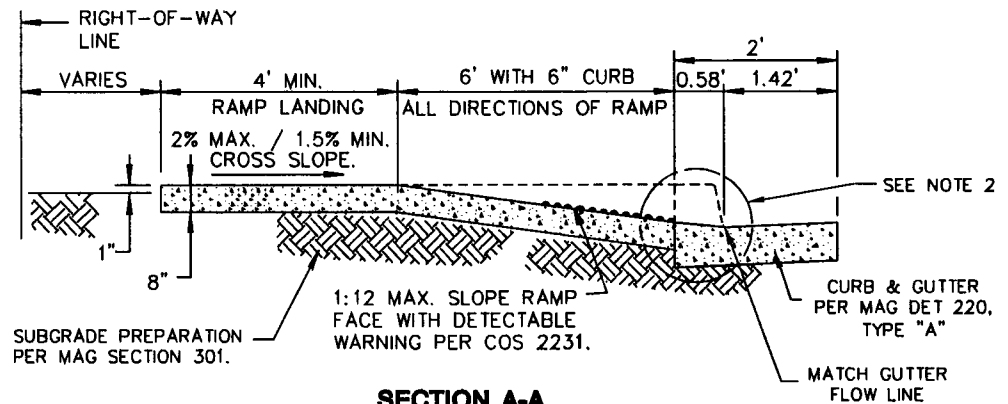

SECTION A-A

NOTES:

1. ALL CONCRETE TO BE CLASS "B", MAG SECTION 725.
2. FOR SLOPING TRANSITION FROM RAMP TO CURB, SEE DETAIL 1 COS 2235.
3. ALL RAMP AND DETECTABLE WARNING SHALL BE ALIGNED IN THE DIRECTION OF PEDESTRIAN TRAVEL AND DIRECTED TOWARD RAMP ON OPPOSITE SIDE OF STREET.
4. USE OF THIS RAMP IS NOT PREFERRED. IT SHALL BE USED ONLY WHERE DIRECTIONAL RAMP ARE NOT POSSIBLE.

DETAIL NO.
2234

**City of Scottsdale
Standard Details**

APPROVED BY:
**Scottsdale Standards &
Specifications Committee**

SHARED CURB SIDEWALK RAMP

DETAIL NO.
2234

REVISED 5/25/05

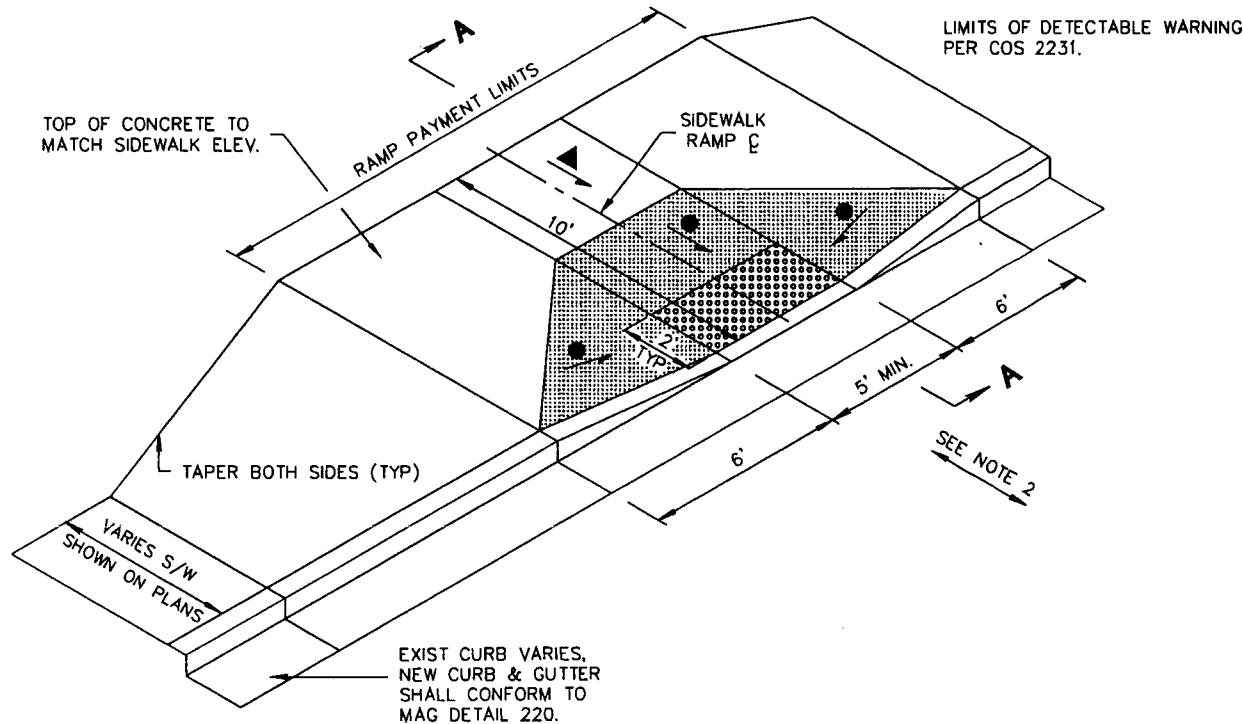

- NOTES:
1. ALL CONCRETE TO BE CLASS "B", MAG SECTION 725.
 2. ALL RAMPS AND DETECTABLE WARNING SHALL BE ALIGNED IN THE DIRECTION OF PEDESTRIAN TRAVEL AND DIRECTED TOWARD RAMP ON THE OPPOSITE SIDE OF STREET.
 3. SEE PLANS FOR LOCATION OF SIDEWALK RAMP CENTERLINE.

- LEGEND**
- 12:1 MAXIMUM SLOPE, 15:1 DESIRED SLOPE
 - ▲ 2% MAXIMUM SLOPE, 1.5% MINIMUM SLOPE
 - ▨ SIDEWALK RAMP PAYMENT LIMITS AND HEAVY ROUGH BROOM FINISH LIMITS

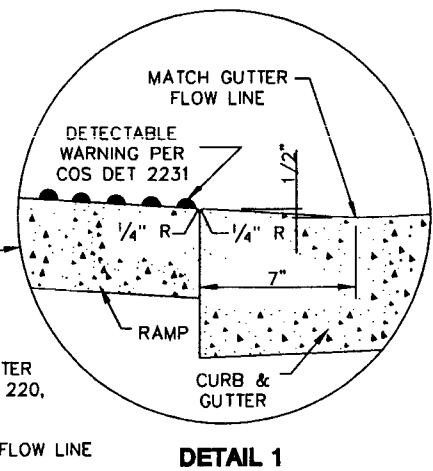
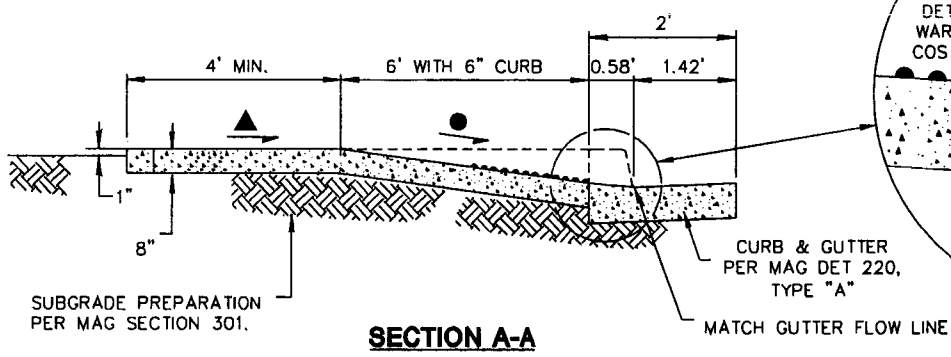

DETAIL NO.
2235-1

City of Scottsdale
Standard Details

APPROVED BY:
Scottsdale Standards & Specifications Committee

MID-BLOCK SIDEWALK RAMP - TYPE A

DETAIL NO.
2235-1

REVISED 5/25/05

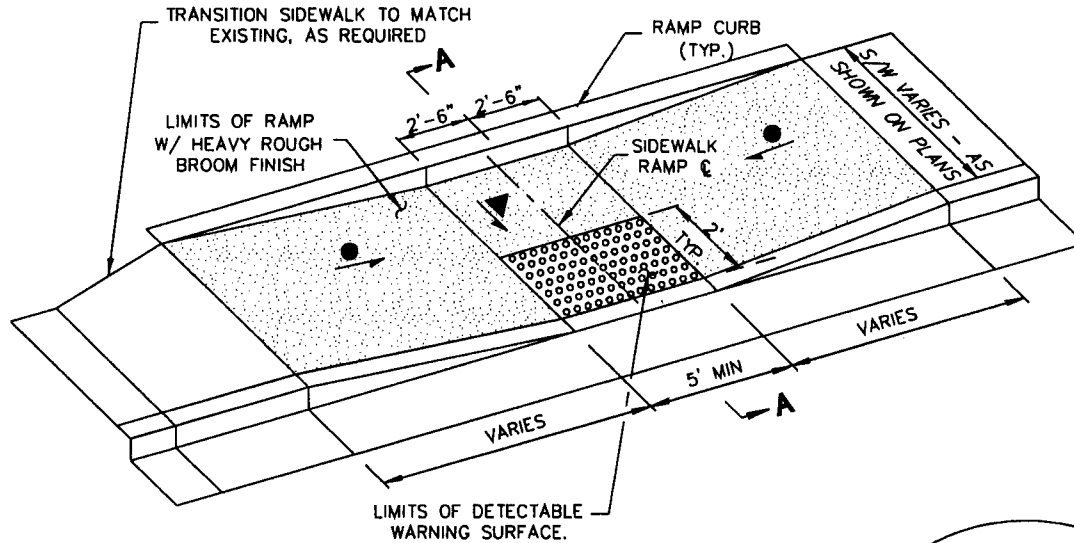

NOTES:

1. ALL CONCRETE TO BE CLASS "B", MAG SECTION 725.
2. ALL RAMPS AND DETECTABLE WARNING SHALL BE ALIGNED IN THE DIRECTION OF PEDESTRIAN TRAVEL AND DIRECTED TOWARD RAMP ON THE OPPOSITE SIDE OF STREET.
3. SEE PLANS FOR LOCATION OF SIDEWALK RAMP CENTERLINE.

LEGEND

- 12:1 MAXIMUM SLOPE, 15:1 DESIRED SLOPE
- 2% MAXIMUM SLOPE, 1.5% MINIMUM SLOPE
- SIDEWALK RAMP PAYMENT LIMITS AND HEAVY ROUGH BROOM FINISH LIMITS

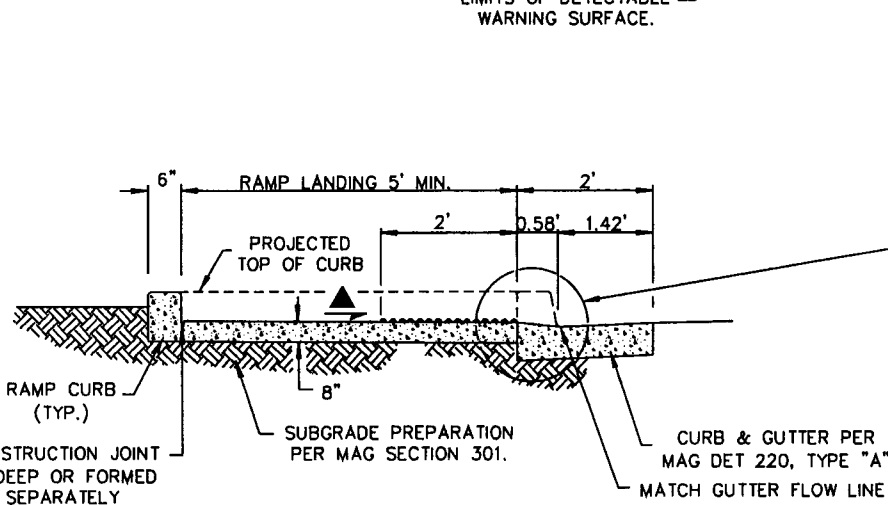

SECTION A-A

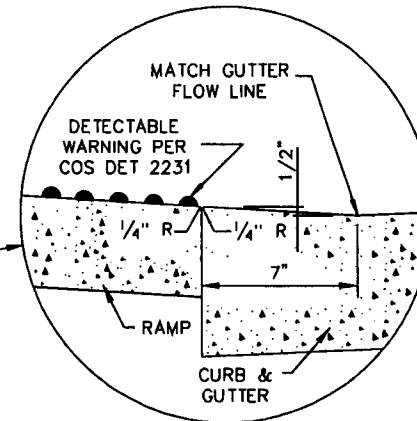

DETAIL 1

DETAIL NO.
2235-2

**City of Scottsdale
Standard Details**

APPROVED BY:
**Scottsdale Standards &
Specifications Committee**

MID-BLOCK SIDEWALK RAMP - TYPE B

DETAIL NO.
2235-2

NOTES:

1. 1/2" Expansion Joint, ASTM D-1751
Per MAG Sec. 729, and Elastomeric Sealant
Per COS Sec. 342.3.4.
2. Contraction Joints Per COS Supplemental
Specifications Sec. 342.
3. Materials And Construction Per COS
Supplemental Specifications Sec. 342.

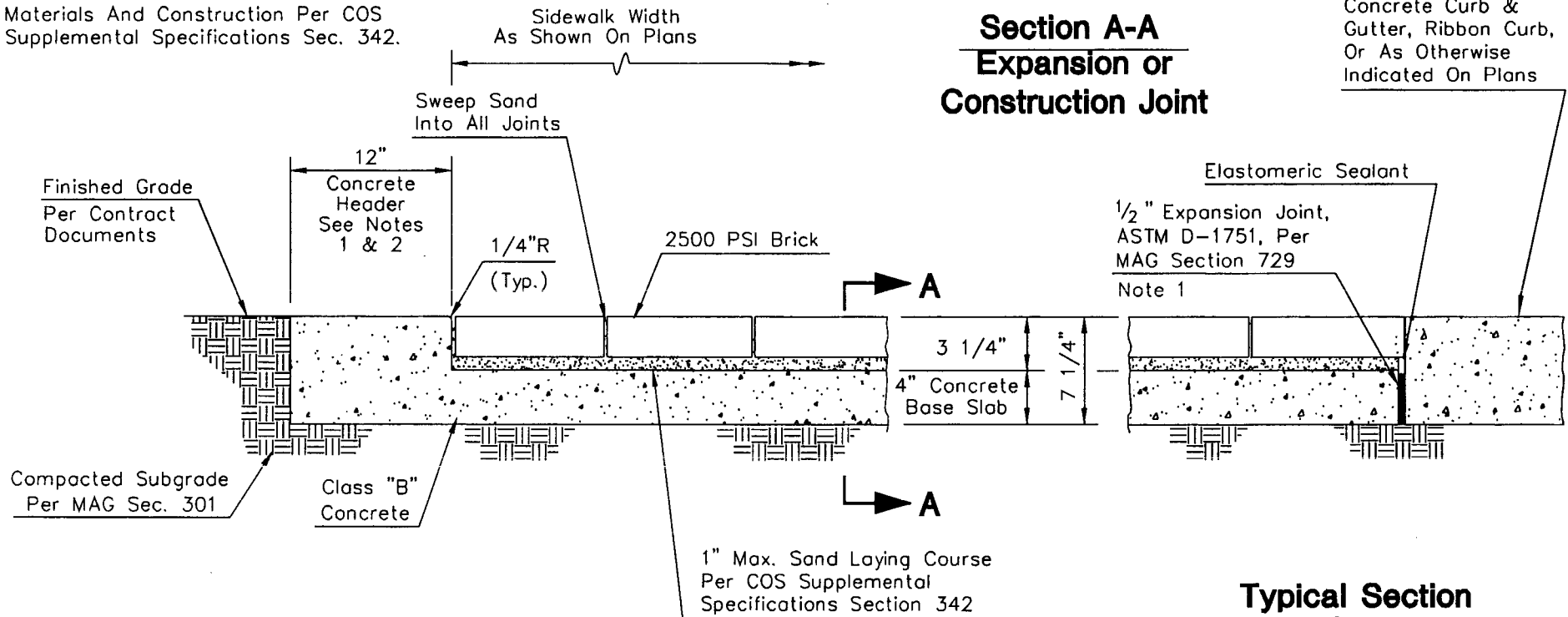
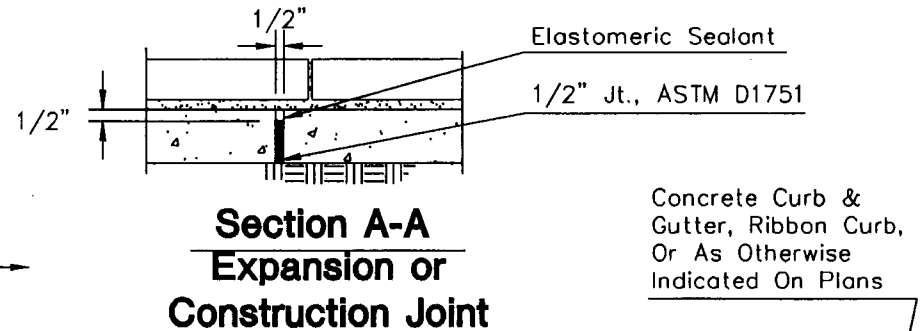

**Typical Half Section
(Against Earth)**

**Typical Section
At End Or Alternate
Half Section
(Against Concrete)**

DETAIL NO.

2237

**City of Scottsdale
Standard Details**

APPROVED BY:
**Scottsdale Standards &
Specifications Committee**

SIDEWALK PAVERS (NON-TRAFFIC BEARING)

DETAIL NO.

2237

NOTES:

1. 1/2" Expansion Joint, ASTM D-1751
Per MAG Sec. 729, and Elastomeric Sealant
Per COS Sec. 342.3.4.
2. Contraction Joints Per COS Supplemental
Specifications Sec. 342.
3. Materials And Construction Per COS
Supplemental Specifications Sec. 342.

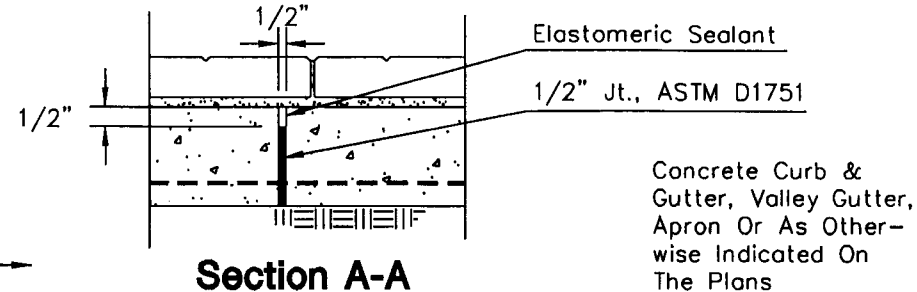

Section A-A
Expansion or Construction Joint

Concrete Curb &
Gutter, Valley Gutter,
Apron Or As Other-
wise Indicated On
The Plans

REVISED 2/27/01

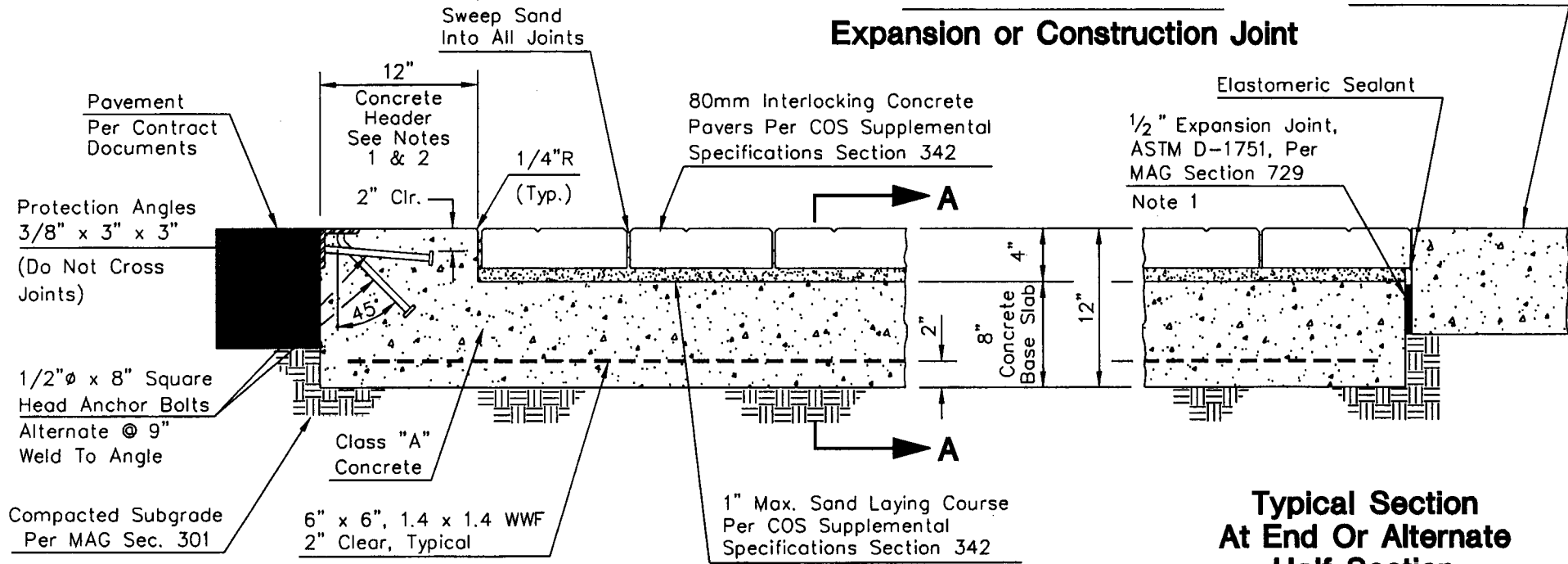

Typical Half Section
(Against Pavement)

Typical Section
At End Or Alternate
Half Section
(Against Concrete)

DETAIL NO. 2238	City of Scottsdale Standard Details	APPROVED BY: Scottsdale Standards & Specifications Committee	CONCRETE PAVER CROSSWALK	DETAIL NO. 2238
---------------------------	---	--	---------------------------------	---------------------------

REVISED 2/26/01

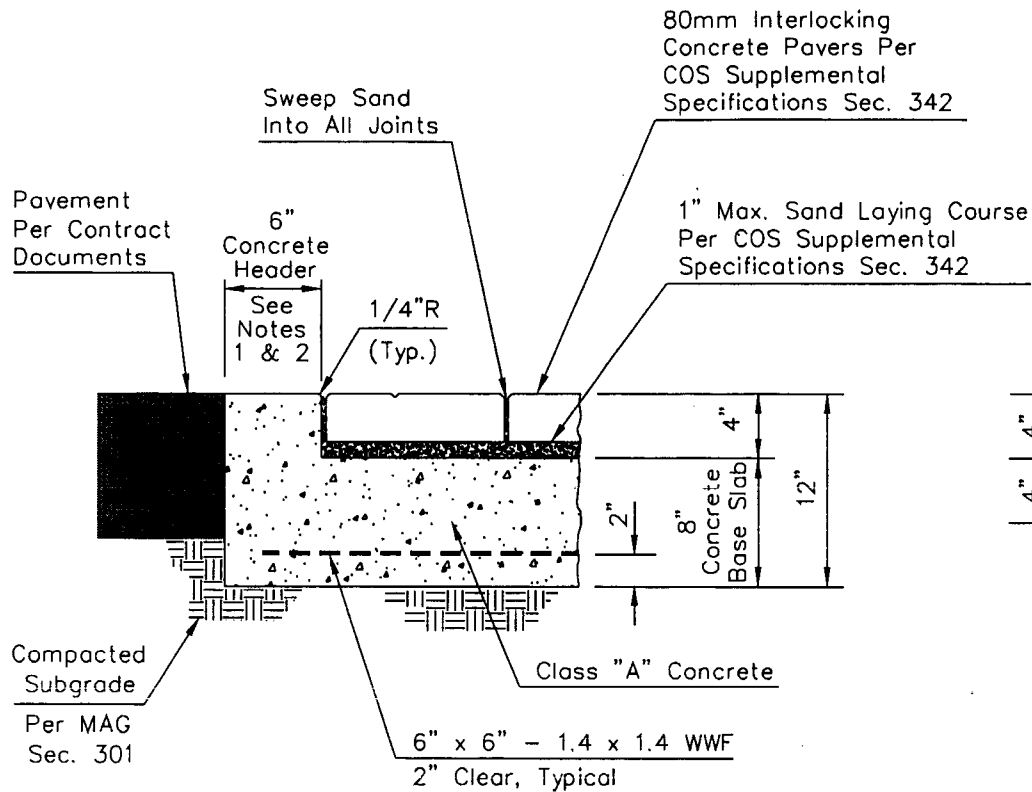

Type "B"
Flush Median

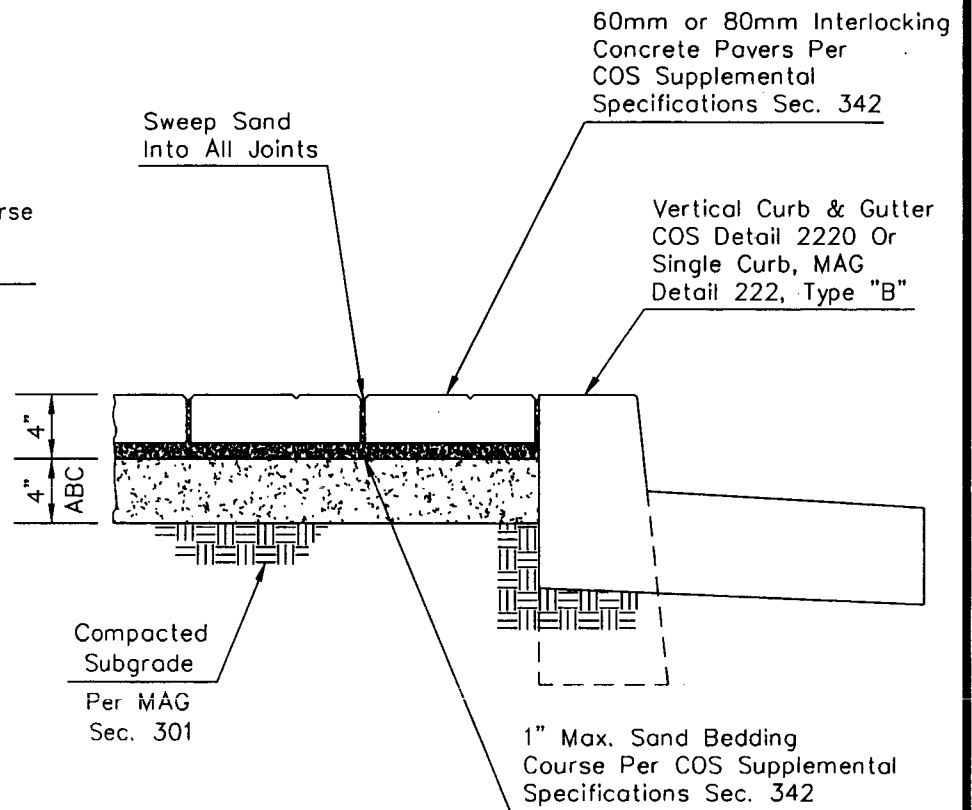

Type "A"
Raised Median

NOTES:

1. 1/2" Expansion Joint, ASTM D-1751 Per MAG Sec. 729, Every 50'.
2. Contraction Joints Per COS Supplemental Specifications Sec. 342, Every 10'.
3. Materials And Construction Per COS Supplemental Specifications Sec. 342.

DETAIL NO.
2239

City of Scottsdale
Standard Details

APPROVED BY:
Scottsdale Standards & Specifications Committee

MEDIAN CONCRETE PAVERS

DETAIL NO.
2239

REVISED 5/10/05

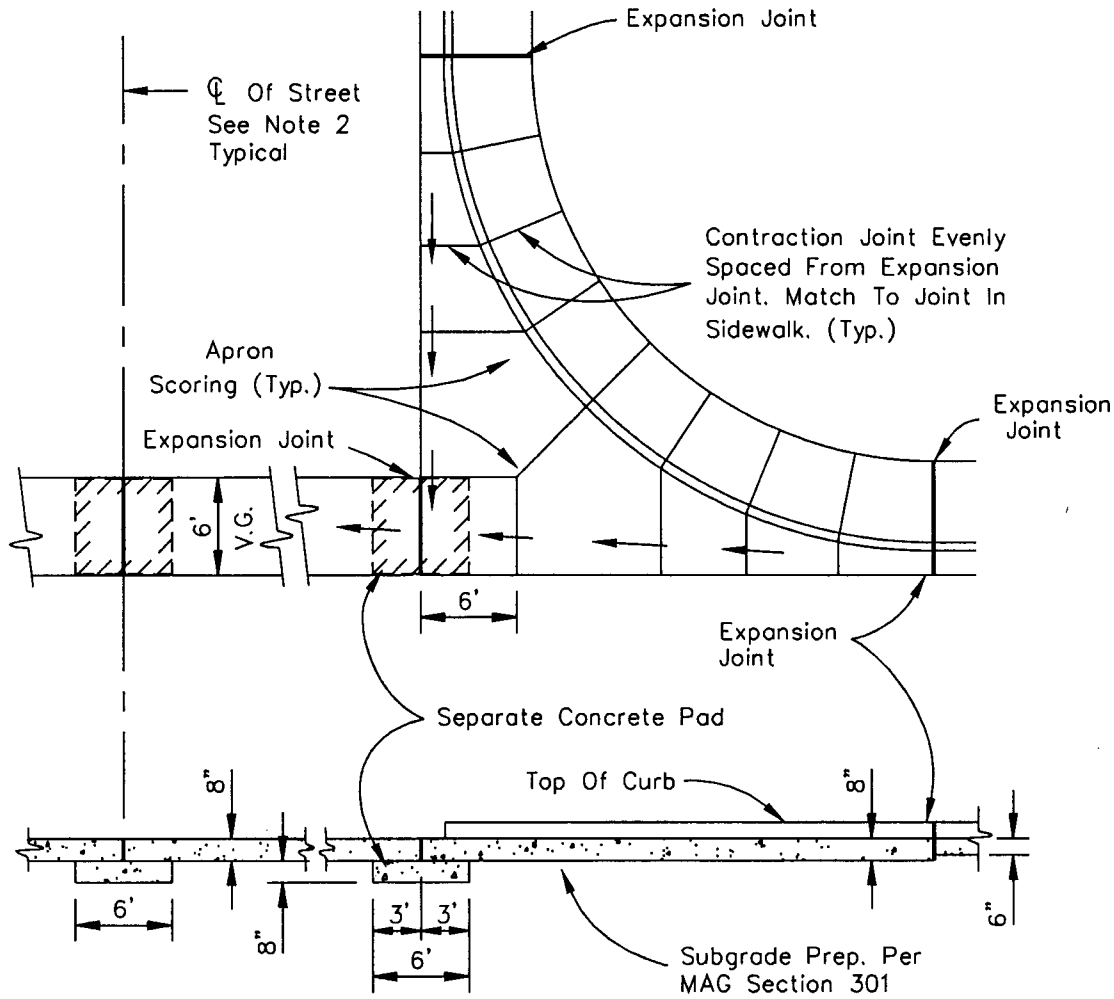

SECTION THRU APRON FLOW-LINE

NOTES

1. All Concrete To Be Class "A", MAG Section 725.
2. Use A Construction Joint Or Contraction Joint At The C Of Street. A Separate Concrete Pad Is Required With A Construction Joint.
3. $\frac{1}{2}$ " Expansion Joint, ASTM D-1751 Per MAG Section 729.
4. Return Curb and Sidewalk to be Monolithically Poured.

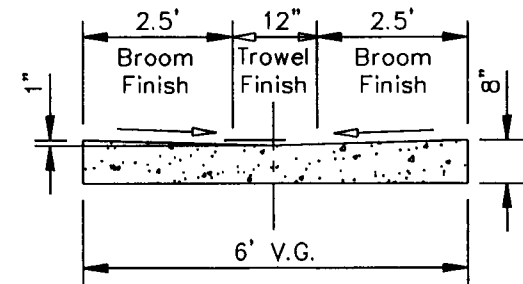

SECTION THRU VALLEY GUTTER

DETAIL NO.
2240

City of Scottsdale
Standard Details

APPROVED BY:
Scottsdale Standards & Specifications Committee

6' VALLEY GUTTER & APRON

DETAIL NO.
2240

REVISED 5/10/05

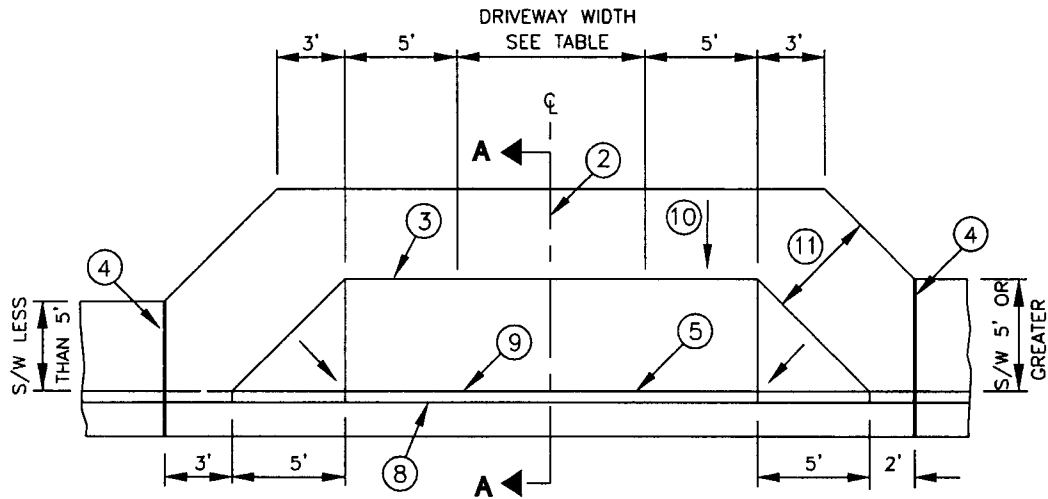

PLAN

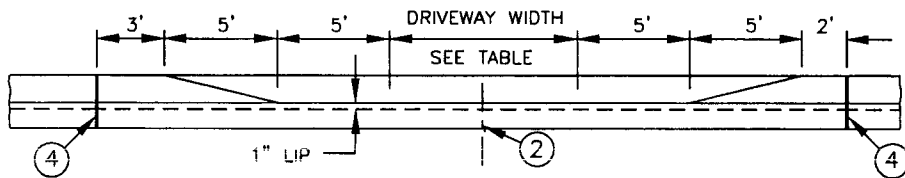

ELEVATION

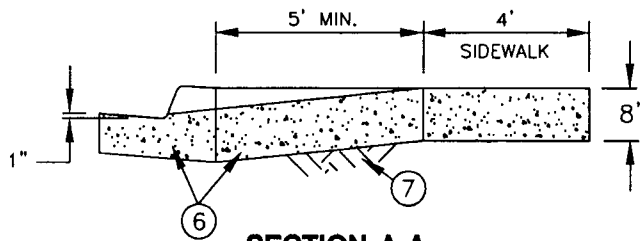

SECTION A-A

NOTES

- 1 DEPRESSED CURB SHALL BE PAID FOR AT THE UNIT PRICE BID FOR THE TYPE OF CURB USED AT THAT LOCATION.
- 2 CONTRACTION JOINT ON DRIVEWAY CENTERLINE.
- 3 BACK OF DRIVEWAY ENTRANCE – CONSTRUCTION JOINT OR SCORE MARK.
- 4 MASTIC EXPANSION JOINT THROUGH CURB AND GUTTER. EXPANSION JOINT FILLER SHALL BE 1/2" BITUMINOUS TYPE PREFORMED EXPANSION JOINT FILLER A.S.T.M. D-1751.
- 5 BACK OF CURB – CONSTRUCTION JOINT OR SCORE MARK.
- 6 CLASS 'B' CONCRETE, MAG SECTION 725.
- 7 SUBGRADE PREPARATION, MAG SECTION 301.
- 8 FLOW LINE OF GUTTER.
- 9 DEPRESSED CURB.
- 10 2% MAXIMUM CROSS SLOPE. 1.5% MINIMUM CROSS SLOPE
- 11 CONCRETE SIDEWALK PER MAG DETAIL 230, MODIFIED. THICKNESS = 8"

COMMERCIAL & INDUSTRIAL			
DRIVEWAY WIDTH	MIN.	MAX.	CLASS
COMMERCIAL ZONING	+ 16'	40'	B
INDUSTRIAL ZONING	+ 16'	40'	B
+ 24' MIN. FOR TWO WAY TRAFFIC			
RESIDENTIAL			
DRIVEWAY WIDTH	MIN.	MAX.	CLASS
MAJOR STREET	16'	30'	B
COLLECTOR STREET	*12'	30'	B
LOCAL STREET	12'	30'	B
* 16' DESIRABLE			

DETAIL NO.
2250

City of Scottsdale
Standard Details

APPROVED BY:
Scottsdale Standards & Specifications Committee

DRIVEWAY ENTRANCES

DETAIL NO.
2250

REVISED 5/10/05

CONSTRUCTION NOTES

1. Sidewalk shall conform to MAG Standard Detail 230 and C.O.S. Sec. 340.
2. Curb as called for on plans.
3. Curb & Gutter shall conform to MAG Standard Detail 220. Single Curb shall conform to MAG Standard Detail 222.
4. Driveway Entrances shall conform to COS Standard Detail 2250. Driveways shall be 2-1/2" A.C. R-19 on 6" A.B.C. unless otherwise noted. See plans for driveway limits.
5. Valley Gutter shall conform to COS Standard Detail 2240.
6. Sidewalk Ramps shall conform to COS Standard Details, Minimum 8" thick.
7. Curb termination similar to MAG Std. Det 222.
8. When installing new driveways along an existing street, sawcut, remove & replace a minimum 2' wide strip of A.C. pavement per COS Standard Detail 2200.
9. All ramps and detectable warning shall be aligned in the direction of pedestrian travel and directed toward ramp on the opposite side of the street.

S-1

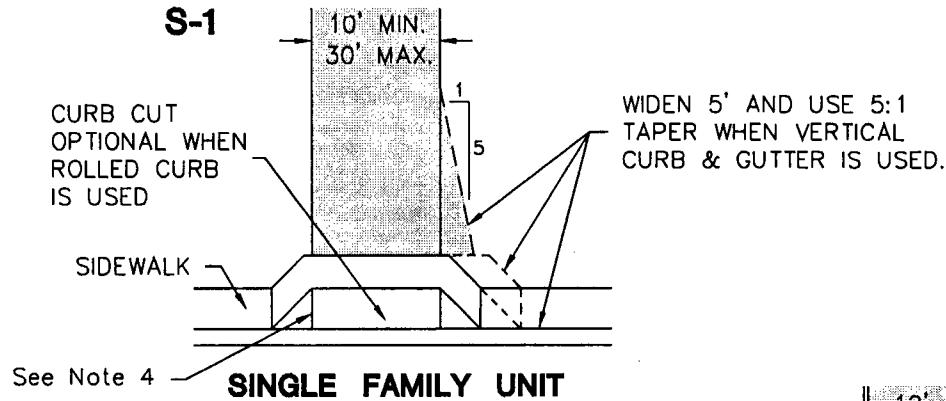

M-1

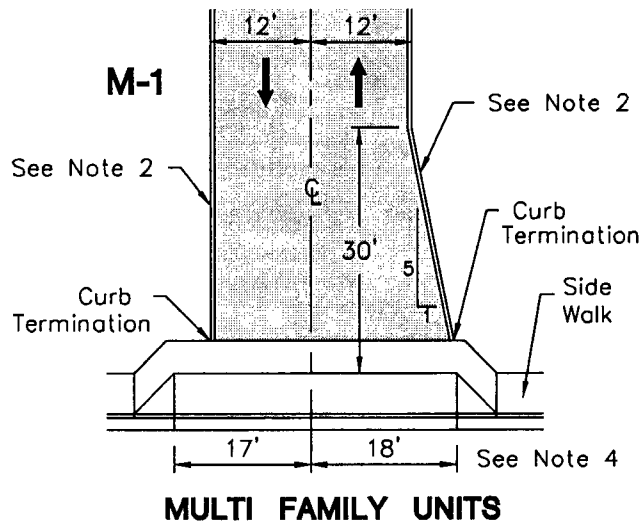

M-2

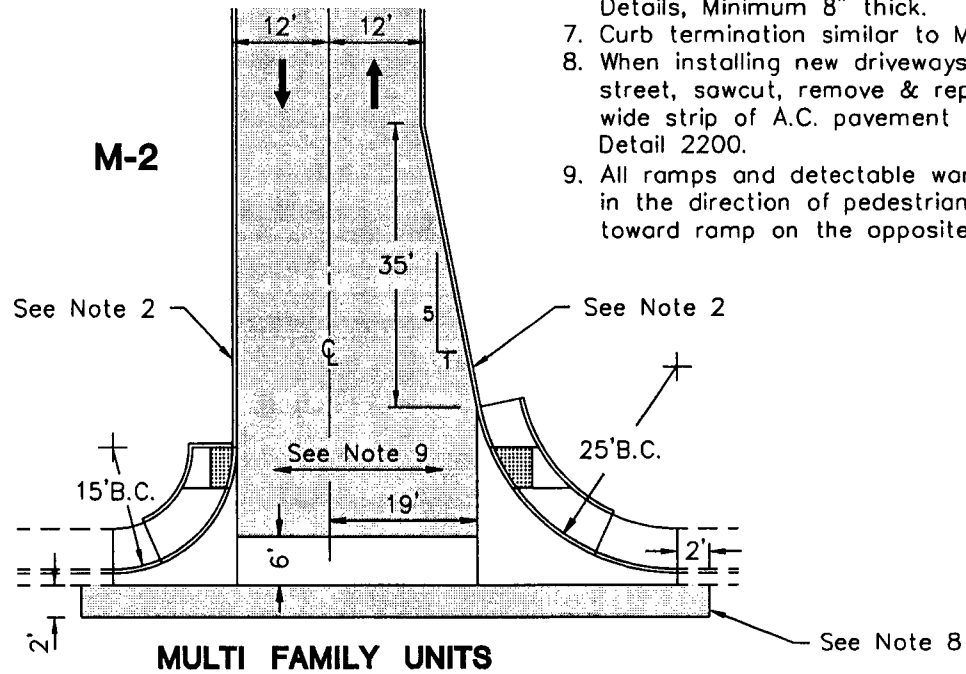

DETAIL NO.
2255

**City of Scottsdale
Standard Details**

APPROVED BY:
**Scottsdale Standards &
Specifications Committee**

RESIDENTIAL DRIVEWAYS

DETAIL NO.
2255

REVISED 5/10/05

CL-3

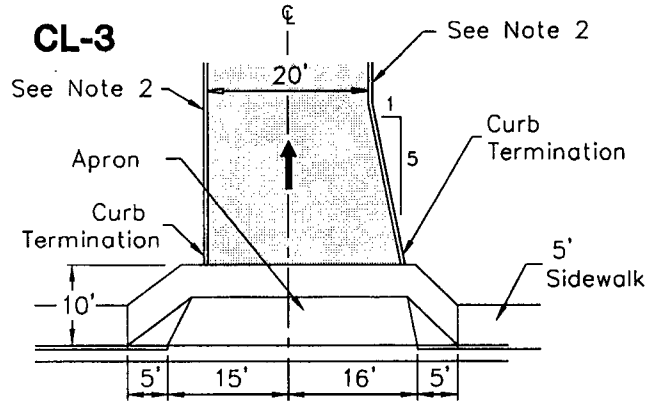

ONE WAY INGRESS

CL-4

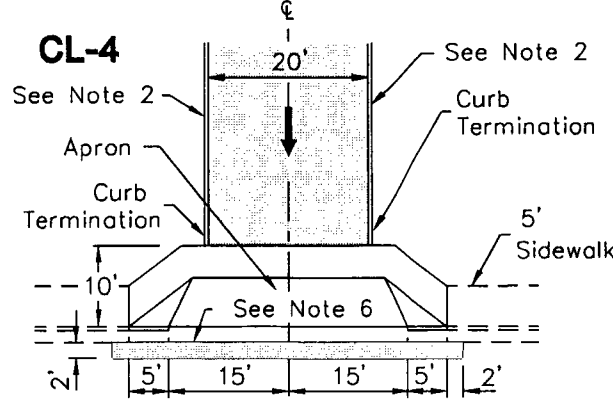

ONE WAY EGRESS

CONSTRUCTION NOTES

1. Sidewalk shall conform to MAG Standard Detail 230 and C.O.S. Sec. 340.
2. Curb as called for on plans.
3. Curb & Gutter shall conform to MAG Standard Detail 220. Single Curb shall conform to MAG Standard Detail 222.
4. Driveway Entrances shall conform to COS Standard Detail 2250 except for modifications as noted. Driveways shall be 2-1/2" A.C. A-19 on 6" A.B.C. unless otherwise noted. See plans for driveway limits.
5. Curb termination similar to MAG Std. Det. 222.
6. When installing new driveways along an existing street, sawcut, remove & replace a minimum 2' wide strip of A.C. pavement per COS Standard Detail 2200.

CL-1

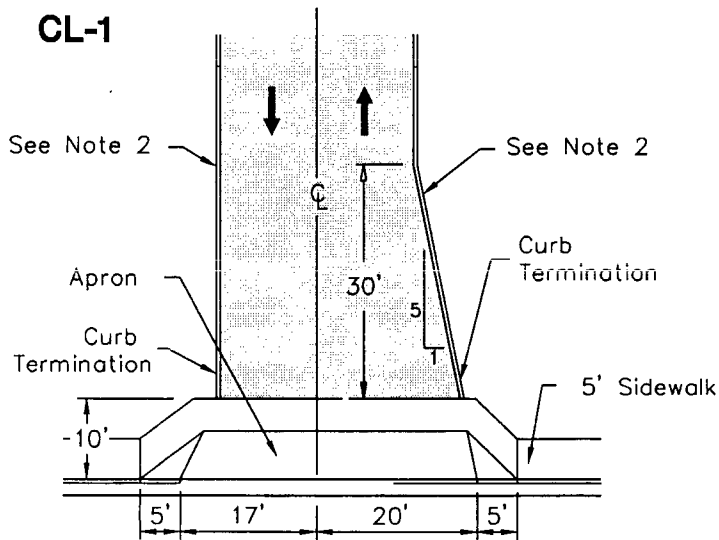

TWO WAY

CL-2

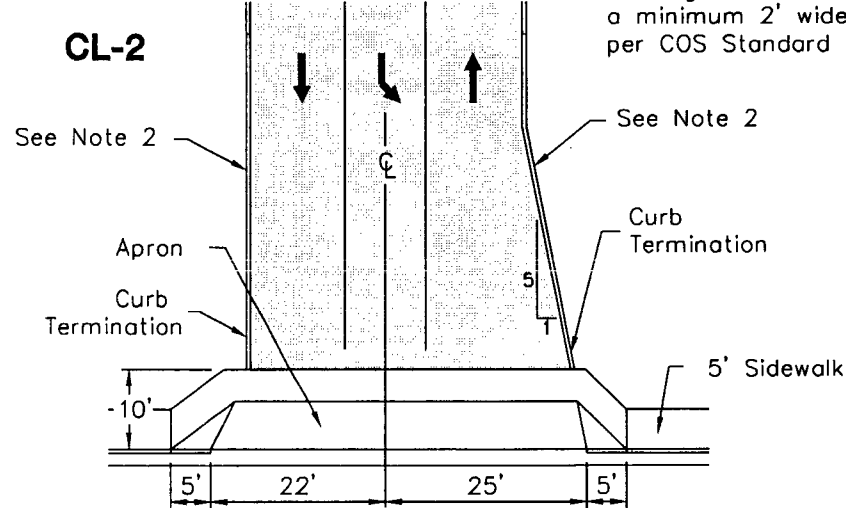

TWO WAY WITH TWO EGRESS LANES

DETAIL NO.
2256

**City of Scottsdale
Standard Details**

APPROVED BY:
**Scottsdale Standards &
Specifications Committee**

COMMERCIAL/INDUSTRIAL DRIVEWAYS-TYPE CL

DETAIL NO.
2256

REVISED 5/10/05

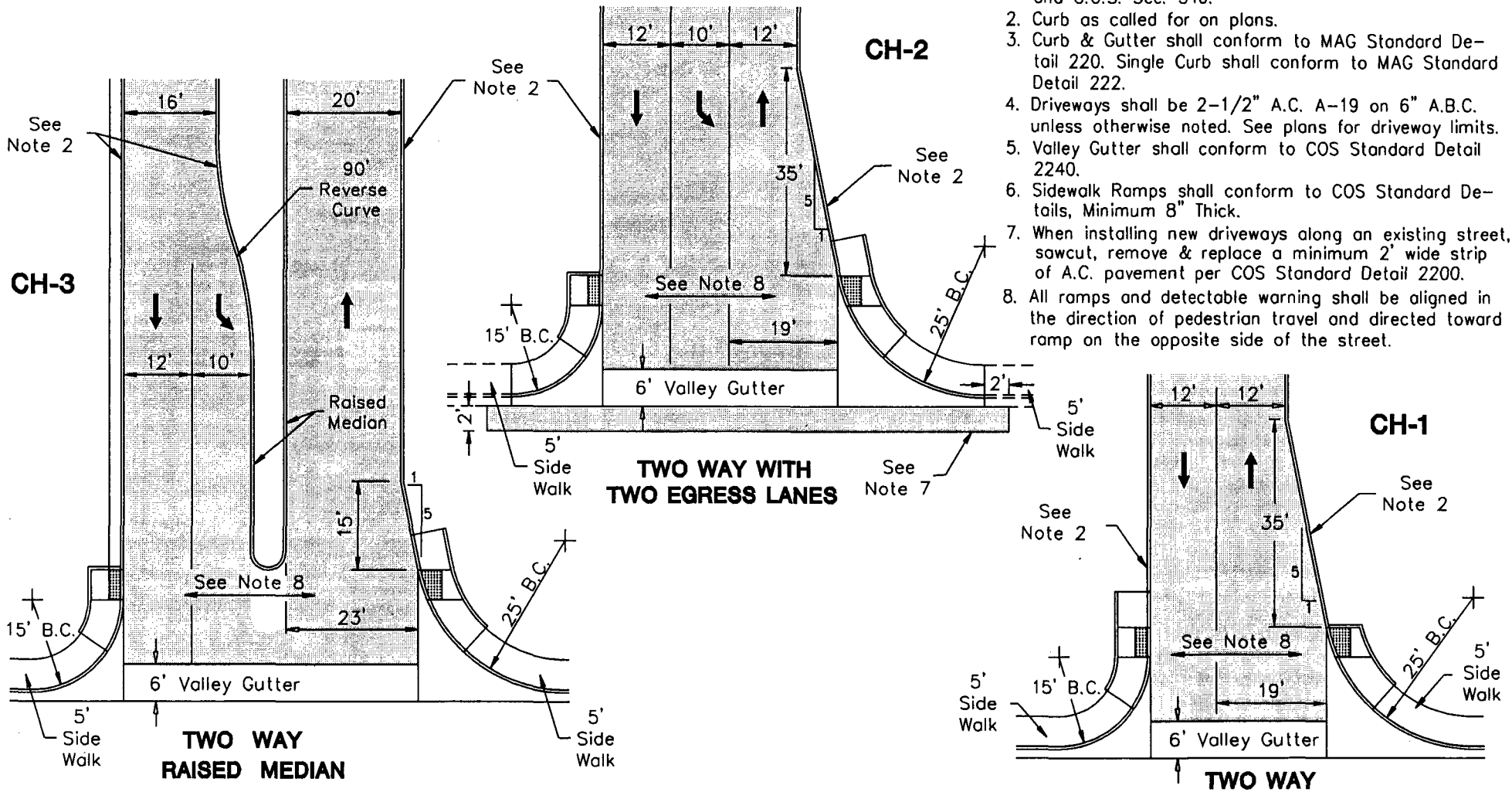

CONSTRUCTION NOTES

1. Sidewalk shall conform to MAG Standard Detail 230 and C.O.S. Sec. 340.
2. Curb as called for on plans.
3. Curb & Gutter shall conform to MAG Standard Detail 220. Single Curb shall conform to MAG Standard Detail 222.
4. Driveways shall be 2-1/2" A.C. A-19 on 6" A.B.C. unless otherwise noted. See plans for driveway limits.
5. Valley Gutter shall conform to COS Standard Detail 2240.
6. Sidewalk Ramps shall conform to COS Standard Details, Minimum 8" Thick.
7. When installing new driveways along an existing street, sawcut, remove & replace a minimum 2' wide strip of A.C. pavement per COS Standard Detail 2200.
8. All ramps and detectable warning shall be aligned in the direction of pedestrian travel and directed toward ramp on the opposite side of the street.

DETAIL NO. **2257** City of Scottsdale Standard Details

APPROVED BY: **Scottsdale Standards & Specifications Committee**

COMMERCIAL/INDUSTRIAL DRIVEWAYS-TYPE CH

DETAIL NO. **2257**

REVISED 5/10/05

CI-1

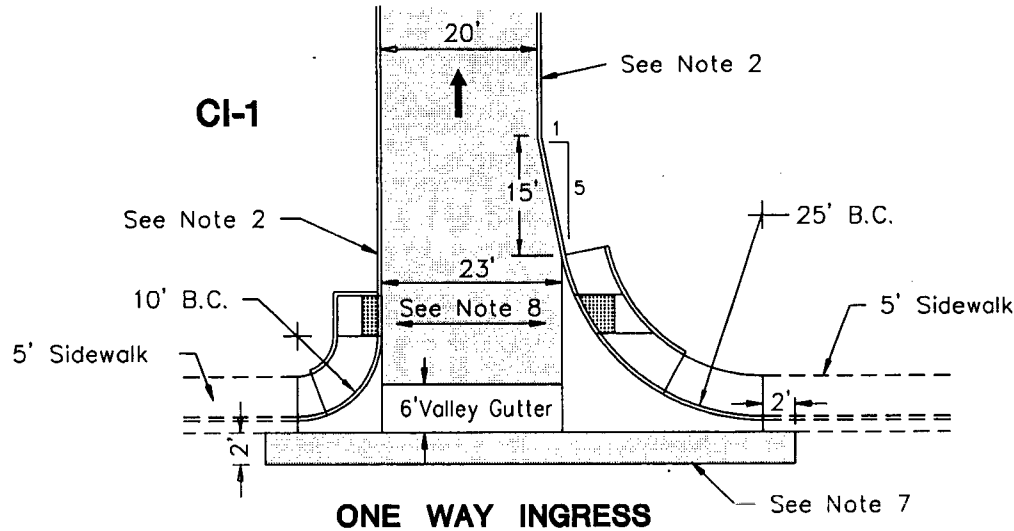

ONE WAY INGRESS

CI-2

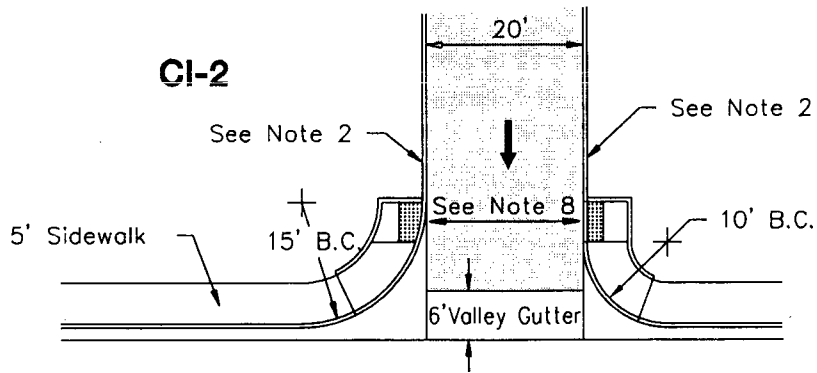

ONE WAY EGRESS

CONSTRUCTION NOTES

1. Sidewalk shall conform to MAG Standard Detail 230 and C.O.S. Sec. 340.
2. Curb as called for on plans.
3. Curb & Gutter shall conform to MAG Standard Detail 220. Single Curb shall conform to MAG Standard Detail 222.
4. Driveways shall be 2-1/2" A.C. A-19 on 6" A.B.C. unless otherwise noted. See plans for driveway limits.
5. Valley Gutter shall conform to COS Standard Detail 2240.
6. Sidewalk Ramps shall conform to COS Standard Details, Minimum 8" Thick.
7. When installing new driveways along an existing street, sawcut, remove & replace a minimum 2' wide strip of A.C. pavement per COS Standard Detail 2200.
8. All ramps and detectable warning shall be aligned in the direction of pedestrian travel and directed toward ramp on the opposite side of the street.

CI-3

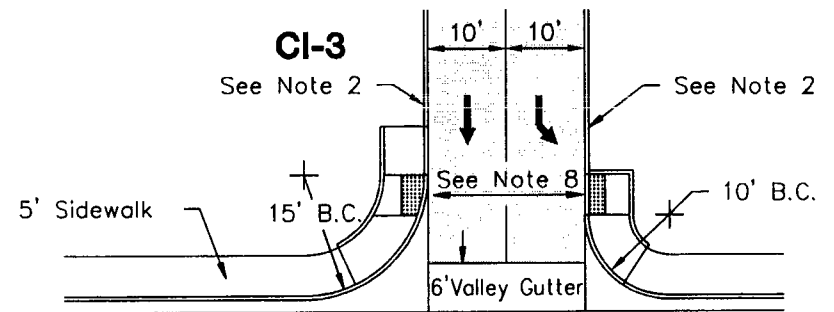

TWO LANES
ONE WAY EGRESS

DETAIL NO.
2258

City of Scottsdale
Standard Details

APPROVED BY:
Scottsdale Standards & Specifications Committee

COMMERCIAL/INDUSTRIAL DRIVEWAYS-TYPE CI

DETAIL NO.
2258

BENCH CONFIRM MFR & MODEL NO.
W/ C.O.S. TRANSPORTATION DIVISION
EXPANSION BOLT TO CONCRETE SLAB
PER MANUFACTURERS SPECIFICATION.
LOCATION SHALL CONFORM TO ADA
REQUIREMENTS. APPROVAL BY C.O.S.
REQUIRED.

1/2"x4" EXPANSION FELT
BOTH SIDES OF BOTTOM
PANELS (TYP OF 4).

4" CONC SLAB
ON 4" A.B.C.

TRASH RECEPT W/ LID -
CONFIRM LOCATION, MFR
& MODEL NO. W/ C.O.S.
TRANSPORTATION DIVISION.
(MIN. 32 GAL CAPACITY).
EXPANSION BOLT TO CONC.
SLAB PER MANUFACTURERS
SPECIFICATION.

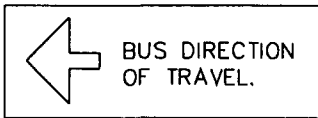
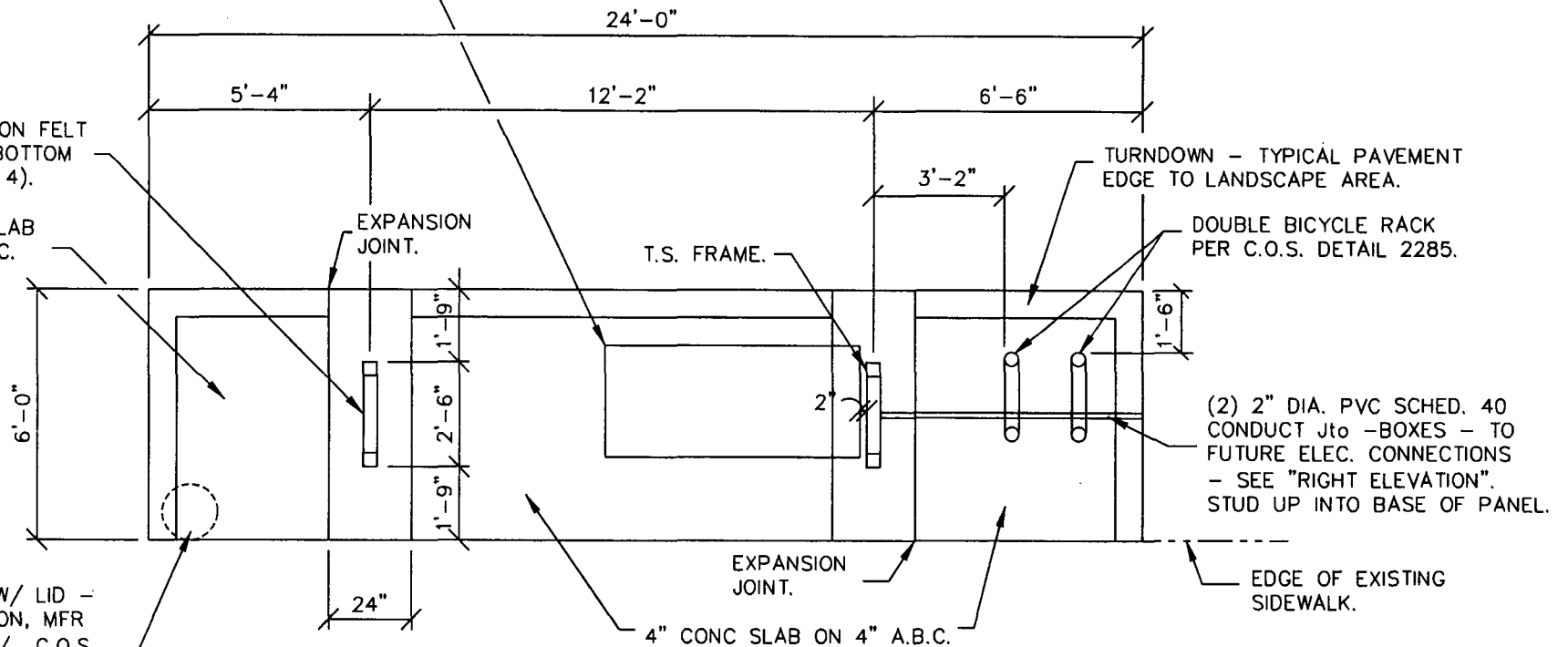

BUS SHELTER FOUNDATION PLAN

N.T.S.

NOTES:

1. SEE SPECIAL REQUIREMENTS (SEE SHEET S1)
2. DEVELOPER OR DEVELOPER'S CONTRACTOR TO DETERMINE SOURCE OF FEED FOR ELECTRICAL SUPPLY, USE 2" SCHEDULE 40 PVC CONDUIT TO EXTEND FROM THE UPRIGHT TO THE SERVICE SOURCE WITH MIN. 3' COVER. IF NO ELECTRICAL SUPPLY EXISTS, STUB CONDUIT 3' BEYOND SHELTER PAD AND CAP BOTH ENDS. CONTACT CITY STAFF TO COORDINATE DIRECTION OF STUB OUT.

DETAIL NO.
2265-1

City of Scottsdale
Standard Details

APPROVED BY:
Scottsdale Standards &
Specifications Committee

BUS SHELTER

DETAIL NO.
2265-1

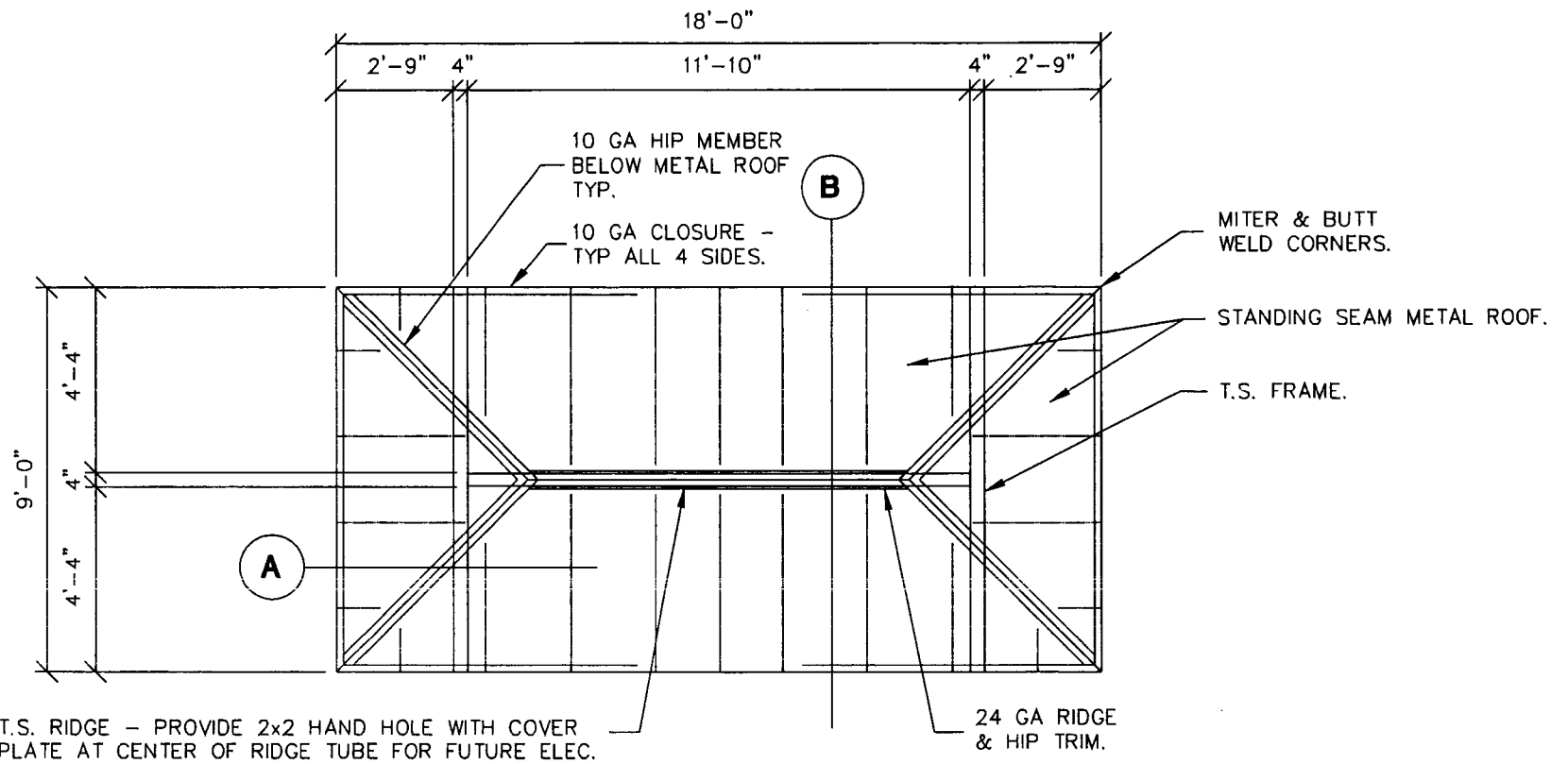

BUS SHELTER FRAMING PLAN

N.T.S.

DETAIL NO.
2265-2

City of Scottsdale
Standard Details

APPROVED BY:
Scottsdale Standards &
Specifications Committee

BUS SHELTER

DETAIL NO.
2265-2

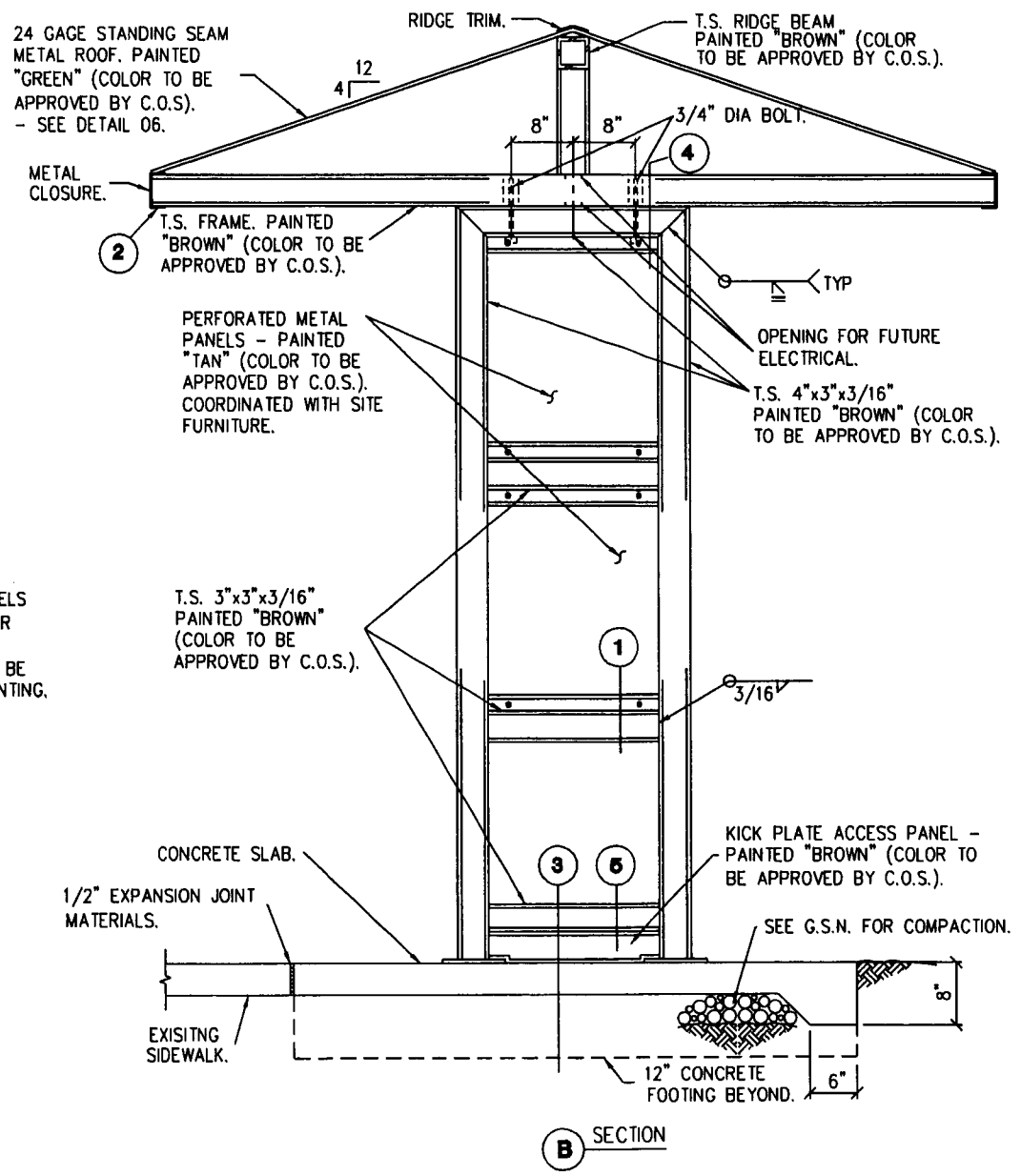
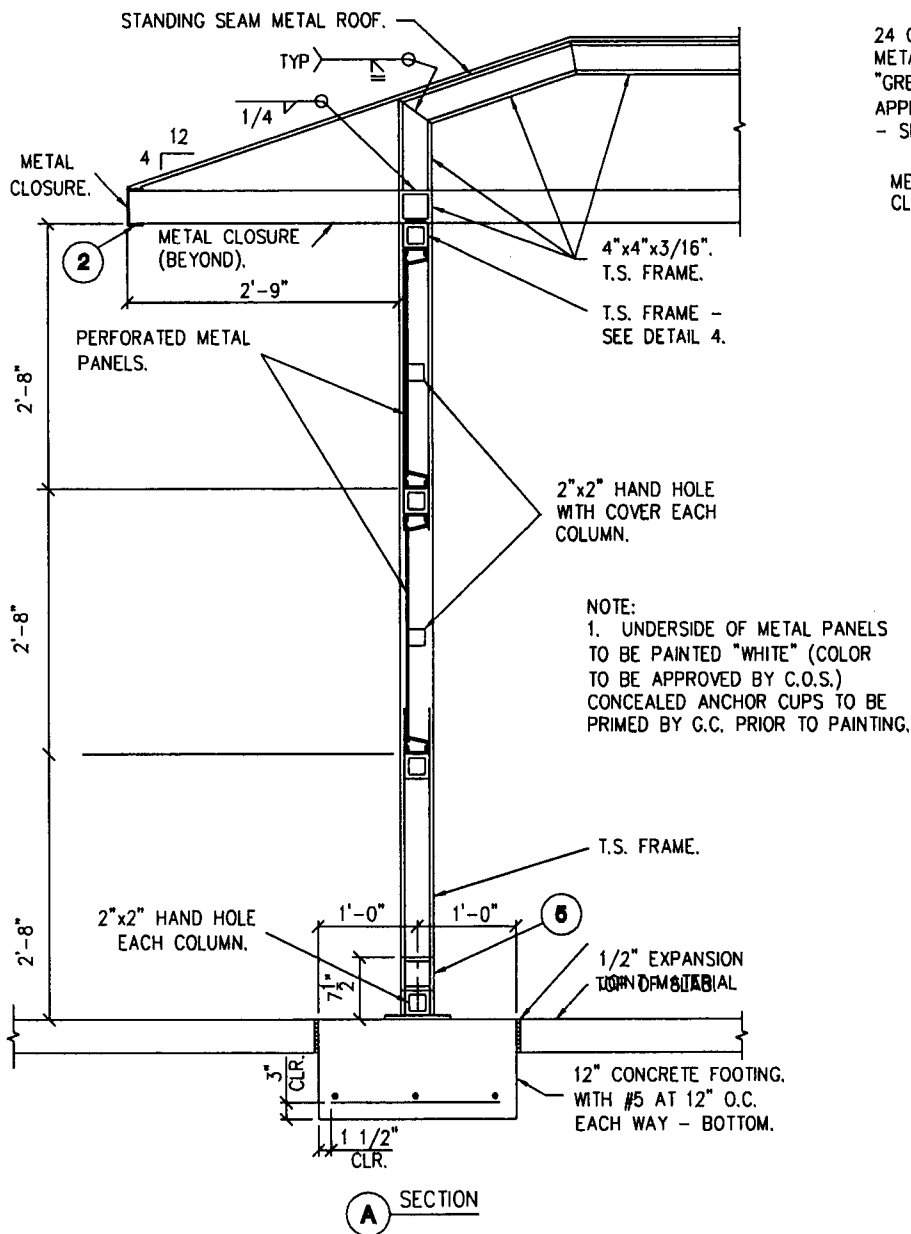

DETAIL NO.
2265-3

City of Scottsdale
Standard Details

APPROVED BY:
Scottsdale Standards &
Specifications Committee

BUS SHELTER

DETAIL NO.
2265-3

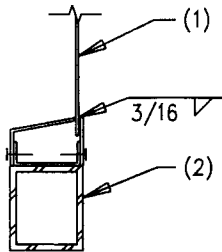

- NOTES:**
1. PREFORATED PANEL. COORDINATE WITH SITE FURNITURE.
 2. STEEL TUBE.

01 PANEL TO FRAME CONNECTION
03-520 NO SCALE

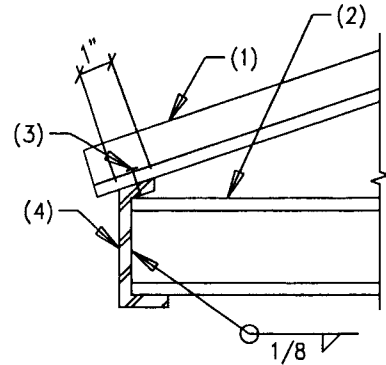

- NOTES:**
1. STANDING SEAM METAL DECK.
 2. STEEL TUBE.
 3. BLACK OXIDE SCREW FASTENER AT 6" O.C. (MIN 4" AT EACH END).
 4. CLOSURE PANEL.

02 TYPICAL CLOSURE
03-520 NO SCALE

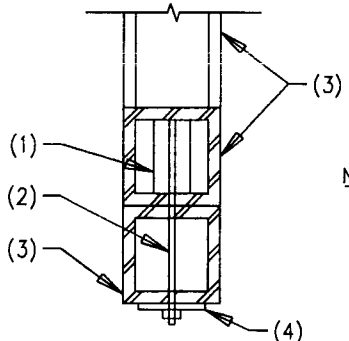

- NOTES:**
1. 3/4" THREAD INSERT.
 2. 3/4" DIA. BOLT.
 3. STEEL TUBE.
 4. 3"x2"x1/4" PLATE WASHER.

04 CONNECTION AT ROOF STRUCTURE
03-520 NO SCALE

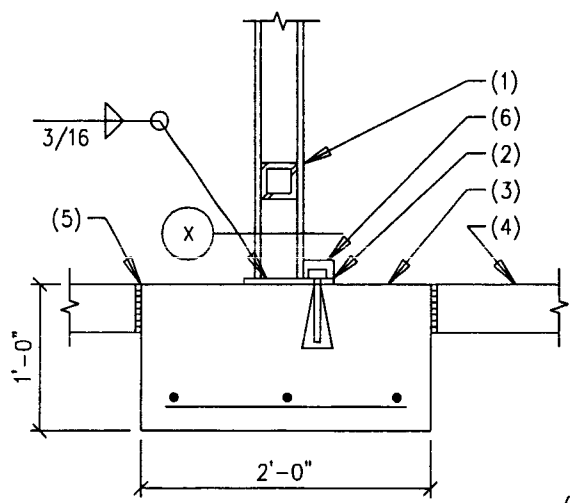

- NOTES:**
1. STEEL TUBE.
 2. BASE PLATE 1/2"x6 1/4"x7 1/2" WITH 2 - 3/4" DIA. x 7" EXPANSION BOLT.
 3. CONCRETE FOOTING.
 4. CONCRETE SLAB.
 5. EXPANSION JOINT MATERIAL.
 6. BOLT COVER SEE DETAIL 08.

03 FOOTING AT T.S. FRAME
03-520 NO SCALE

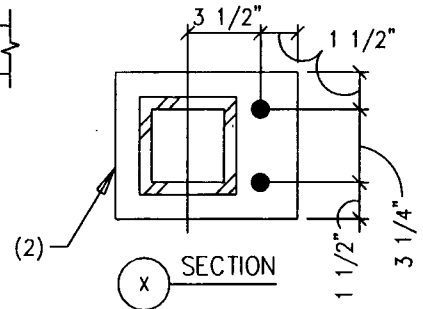

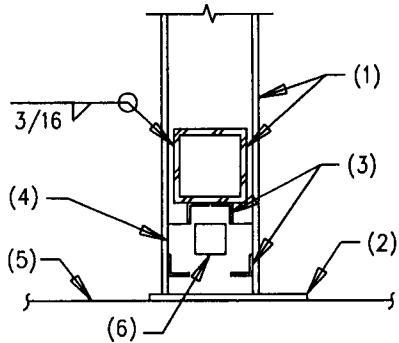

- NOTES:
1. STEEL TUBE.
 2. BASE PLATE - SEE DETAIL 03.
 3. 1"x1" ANGLE.
 4. 16 GAGE PANEL.
 5. TOP OF SLAB.
 6. 2"x2" HAND HOLE AT TUBE FRAME BEYOND - SEE SECTION A FOR LOCATIONS.

05 KICK PLATE ACCESS PANEL

03-520 NO SCALE

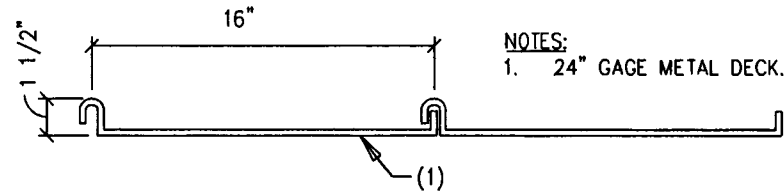

- NOTES:
1. 24" GAGE METAL DECK.

06 STANDING SEAM METAL DECK

03-520 NO SCALE

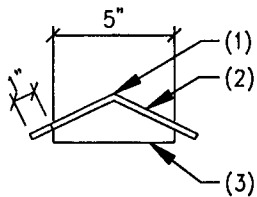

- NOTES:
1. $S_y = .058$
 $I_x = .0219$
 $F_y = 50$ KSI.
 2. 10 GAGE HIP MEMBER BELOW METAL ROOF - TYP.
 3. 22 GAGE METAL SNAP COVER PLATE - CREASE MIDDLE; TRIM EDGES TO FIT END CONDITIONS.

07 METAL COVER PLATE

03-520 NO SCALE

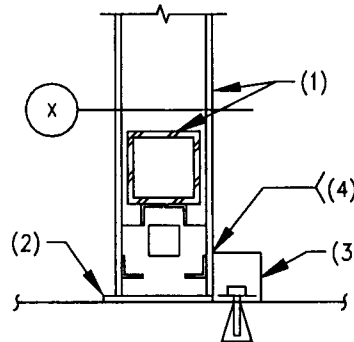

- NOTES:
1. STEEL TUBE.
 2. BASE PLATE.
 3. 16 GAGE METAL COVER.
 4. TACK WELD.

NOTE:
FOR INFORMATION SHOWN BUT NOT NOTED SEE DET 05.

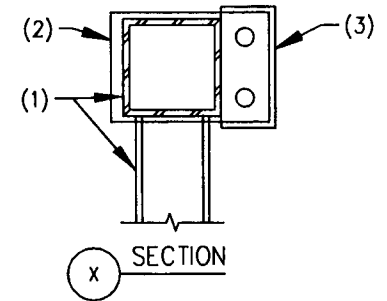

X SECTION

08 BOLT COVER

03-520 NO SCALE

GENERAL STRUCTURAL NOTES

BUILDING CODE:

2003 EDITION OF THE UNIFORM BUILDING CODE, WITH CITY OF SCOTTSDALE AMENDMENTS.

LOADS:

LATERAL:

WIND LOAD = 90 MPH WIND SPEED, EXPOSURE C. SEISMIC ZONE 2B (Z = 0.075)

FOUNDATIONS:

COMPACT SUB GRADE AND BASE MATERIAL TO 95% OF THE ASTM D698 MAXIMUM DRY DENSITY.

CONCRETE:

MINIMUM 28 DAY STRENGTH 3,000 PSI

ALL CAST-IN-PLACE CONCRETE CONSTRUCTION SHALL CONFORM TO THE LATEST EDITION OF THE ACI. FOR CONCRETE WITHOUT PLASTICIZER, MAXIMUM SLUMP 4 1/2" AT POINT OF PLACEMENT U.N.O. IF PLASTICIZER IS USED, A HIGHER FINAL SLUMP MAY BE ALLOWED UPON STRUCTURAL ENGINEER'S APPROVAL.

REINFORCING:

ALL REINFORCING PER CRSI SPECIFICATIONS AND HANDBOOK. ASTM A615 (Fy = 60 KSI/GRADE 60) DEFORMED BARS FOR ALL BARS.

ALL REINFORCING SHALL BE CHAIRED TO ENSURE PROPER CLEARANCES. SUPPORT OF FOUNDATION REINFORCING MUST PROVIDE ISOLATION FROM MOISTURE CORROSION BY USE OF A PLASTIC OR CONCRETE CHAIR. DUCT-TAPE COVERED REINFORCING IS NOT AN ACCEPTABLE CHAIR.

ALL DIMENSIONS REFERENCED IN DRAWINGS AS "CLEAR" SHALL BE FROM FACE OF STRUCTURE TO EDGE OF REINFORCING, AND SHALL NOT BE LESS THAN STATED, NOR GREATER THAN "CLEAR" DIMENSION PLUS 3/8". ALL OTHERS SHALL BE PLUS OR MINUS 1/4" TYPICAL UNLESS NOTED OTHERWISE.

STRUCTURAL STEEL:

ALL CONSTRUCTION PER LATEST AISC HANDBOOK. ALL TUBE STEEL SHALL BE ASTM A500(Fy=46 KSI). ALL MISCELLANEOUS STEEL UNLESS NOTED OTHERWISE SHALL BE ASTM A36 (Fy = 36 KSI).

UNLESS NOTED OTHERWISE, ALL WELDS PER LATEST EDITION OF THE AWS STANDARDS. ALL WELDING SHALL BE PERFORMED BY WELDERS HOLDING VALID CERTIFICATES AND HAVING CURRENT EXPERIENCE IN THE TYPE OF WELD SHOWN ON THE DRAWINGS OR NOTES. CERTIFICATES SHALL BE THOSE ISSUED BY AN ACCEPTED

STRUCTURAL STEEL: CONT'D

TESTING AGENCY. ALL WELDING DONE BY E70 SERIES LOW HYDROGEN RODS UNLESS NOTED OTHERWISE. FOR GRADE 60 REINFORCING BARS, USE E90 SERIES. THESE DRAWINGS DO NOT DISTINGUISH BETWEEN SHOP AND FIELD WELDS; THE CONTRACTOR MAY SHOP WELD OR FIELD WELD AT THEIR DISCRETION. SHOP WELDS AND FIELD WELDS SHALL BE SHOWN ON THE SHOP DRAWINGS SUBMITTED FOR REVIEW.

STEEL DECKING:

ALL STANDING SEAM DECK SHALL CARRY A U.L. 90 UPLIFT RATING. INSTALLATION SHALL CONFORM TO STANDARDS SET FORTH IN THE ARCHITECTURAL SHEET METAL MANUAL PUBLISHED BY SMACNA.

WELDERS EXPERIENCED IN LIGHT GAGE STEEL DECK WORK SHALL PERFORM ALL WELDING. DECK WELDING MAY BE ACHIEVED WITH E60 SERIES NON LOW HYDROGEN RODS OR E70 SERIES LOW HYDROGEN RODS.

SCREWS WHERE INDICATED SHALL BE #12-24 TRAXX PER ICBO 3056 OR APPROVED EQUIVALENT.

SHOP DRAWINGS:

SHOP DRAWINGS SHALL BE SUBMITTED FOR ALL STRUCTURAL ITEMS.

THE CONTRACTOR SHALL REVIEW ALL SHOP DRAWINGS PRIOR TO SUBMITTAL. ITEMS NOT IN ACCORDANCE WITH CONTRACT DOCUMENTS SHALL BE FLAGGED UPON CONTRACTOR'S REVIEW.

MANUFACTURER OR FABRICATOR SHALL CLOUD ANY CHANGES, SUBSTITUTIONS, OR DEVIATIONS FROM CONTRACT DOCUMENTS. ANY OF THE FOREMENTIONED WHICH ARE NOT CLOUDED OR FLAGGED BY SUBMITTING PARTIES, SHALL NOT BE CONSIDERED APPROVED AFTER ENGINEER'S REVIEW, UNLESS NOTED ACCORDINGLY.

THE ENGINEER HAS THE RIGHT TO APPROVE OR DISAPPROVE ANY CHANGES TO CONTRACT DOCUMENTS AT ANYTIME BEFORE OR AFTER SHOP DRAWING REVIEW.

THE SHOP DRAWINGS DO NOT REPLACE THE CONTRACT DOCUMENTS. ITEMS OMITTED OR SHOWN INCORRECTLY AND ARE NOT FLAGGED BY THE STRUCTURAL ENGINEER OR ARCHITECT SHALL NOT BE CONSIDERED CHANGES TO CONTRACT DOCUMENTS. IT IS THE CONTRACTOR'S RESPONSIBILITY TO ENSURE ITEMS ARE CONSTRUCTED TO CONTRACT DOCUMENTS. THE ADEQUACY OF ENGINEERING DESIGNS AND LAYOUT PERFORMED BY OTHERS RESTS WITH THE DESIGNING OR SUBMITTING AUTHORITY.

SHOP DRAWINGS: CONT'D

REVIEWING IS INTENDED ONLY AS AN AID TO THE CONTRACTOR IN OBTAINING CORRECT SHOP DRAWINGS. RESPONSIBILITY FOR CORRECTNESS SHALL REST WITH THE CONTRACTOR.

SPECIAL REQUIREMENTS

1. AN ARTIST-DESIGNED SHELTER MAY BE SUBSTITUTED FOR STANDARD SHELTER BY APPROVAL OF THE CITY OF SCOTTSDALE TRANSIT SECTION. HOWEVER, IT MUST INCORPORATE ALL THE FUNCTIONAL ELEMENTS INCLUDED IN THE STANDARD SHELTER. SEE TRANSIT & DESIGN REVIEW STAFF FOR DETAILS.

2. STANDARD BUS STOP SIGN LOCATION, NEW OR RELOCATED SIGNS SHALL BE APPROVED BY THE TRAFFIC/TRANSIT STAFF.

3. ADDITIONAL REQUIREMENTS MAY INCLUDE:

- A) LEANING RAIL.
- B) LED REAL TIME BUS INFORMATION SIGN.
- C) BUS ROUTE/TRAFFIC INFORMATION KIOSKS.

D) PEDESTRIAN RAILING AROUND THE BACK OF SHELTER ADJACENT TO STEEP SLOPES OR DROP-OFFS.

4. CITY OF SCOTTSDALE TRANSIT BUS SHELTERS SHALL BE PROVIDED WITH A GROUNDING SYSTEM THAT MAY CONSIST OF ONE OF THE FOLLOWING METHODS:

A) 25 FEET OF #4 STANDARD COPPER (UNINSULATED) INSTALLED IN THE BASE OF ONE OF THE UPRIGHT FOUNDATIONS. THE GROUNDING CONDUCTOR WILL EXTEND OUT OF THE POURED CONCRETE FOUNDATION WITH A LENGTH NOT TO EXCEED 3 FEET. THE GROUNDING CONDUCTOR WILL BE WRAPPED IN A CLOCKWISE ROTATION, ONE WRAP, AROUND ON THE THE UPRIGHT ANCHOR BOLTS. A FLAT FENDER WASHER WILL BE INSTALLED ON TOP OF THE CONDUCTOR WITH THE ANCHOR BOLT NUT ON TOP OF THE FLAT WASHER AND SECURED.

B) A SECOND METHOD WILL CONSIST OF A 5/8"x 8'-0" GROUND ROD DRIVEN IN THE ELECTRICAL PULLBOX ADJACENT TO THE BUS SHELTER. A GROUND ROD TERMINAL NUT (ACORN NUT) WILL BE INSTALLED ON TOP OF THE GROUND ROD SECURING A #8 AWG BARE SOLID COPPER WIRE. THE GROUND WIRE WILL BE INSTALLED FROM THE JUNCTION BOX, UNBROKEN AND UNSPLICED, TO THE BUS SHELTER UPRIGHT WHERE IT WILL BE TERMINATED. A SET-SCREW TERMINAL LUG WILL BE FASTENED TO THE STRUCTURE UPRIGHT UNDER THE BOTTOM KICKPANEL. THE AREA UNDER THE TERMINAL LUG WILL BE CLEANED OF ALL RUST, SCALE AND PAINT. THE #8 BARE BOND CONDUCTOR WILL BE TERMINATED IN THE SET-SCREW TERMINAL LUG.

BOTH GROUNDING METHODS WILL BE DONE IN ACCORDANCE WITH ARTICLE 250 OF NATIONAL ELECTRICAL CODE.

DETAIL NO.

2265-6

**City of Scottsdale
Standard Details**

APPROVED BY:

**Scottsdale Standards &
Specifications Committee**

BUS SHELTER

DETAIL NO.

2265-6

ABBREVIATIONS

NOTE: ABBREVIATIONS MAY OR MAY NOT HAVE PERIODS, BUT SHALL BE READ AS SAME.

A.B. _____ ANCHOR BOLT
 A.B.C. _____ AGGREGATE BASE COURSE
 ACI _____ AMERICAN CONCRETE INSTITUTE
 A/C _____ AIR CONDITIONER
 A.F.F. _____ ABOVE FINISHED FLOOR
 AISC _____ AMERICAN INSTITUTE OF STEEL CONSTRUCTION
 AISI _____ AMERICAN IRON AND STEEL INSTITUTE
 AITC _____ AMERICAN INSTITUTE OF TIMBER CONSTRUCTION
 ALT. _____ ALTERNATE
 ANSI _____ AMERICAN NATIONAL STANDARDS INSTITUTE
 APA _____ AMERICAN PLYWOOD ASSOCIATION
 ARCH'L _____ ARCHITECTURAL
 ASTM _____ AMERICAN SOCIETY FOR TESTING AND MATERIALS
 AWS _____ AMERICAN WELDING SOCIETY
 @ _____ AT (MEASUREMENT)
 BM _____ BEAM
 B.F.F. _____ BELOW FINISHED FLOOR
 BLK _____ BLOCK
 B.O.B. _____ BOTTOM OF BEAM
 B.O.D. _____ BOTTOM OF DECK
 B.O.F. _____ BOTTOM OF FOOTING
 BRG _____ BEARING
 C _____ CAMBER
 C.C. _____ CENTERLINE TO CENTERLINE
 C.G. _____ CENTER OF GRAVITY
 C.I.P. _____ CAST IN PLACE
 C.L. _____ CENTERLINE
 C.L.B. _____ CENTERLINE OF BEAM
 C.L.C. _____ CENTERLINE OF COLUMN
 C.L.F. _____ CENTERLINE OF FOOTING
 C.L.W. _____ CENTERLINE OF WALL
 CLR _____ CLEAR
 CONC _____ CONCRETE
 CONC C.J. _____ CONCRETE CONTROL JOINT
 CONC S.J. _____ CONCRETE SAWCUT JOINT
 C.M.U. _____ CONCRETE MASONRY UNIT
 CONN _____ CONNECTION
 CONT _____ CONTINUOUS
 C.O.S. _____ CITY OF SCOTTSDALE
 CRSI _____ CONCRETE REINFORCING STEEL INSTITUTE
 DL _____ DEAD LOAD
 ∅ OR DIA _____ DIAMETER

DN _____ DOWN
 DWG(S) _____ DRAWING(S)
 E.C. _____ END TO CENTERLINE
 E.E. _____ END TO END
 E.O.S. _____ EDGE OF SLAB
 EQ _____ EQUAL
 EQUIP _____ EQUIPMENT
 EXP. BOLT (E.B.) _____ EXPANSION BOLT
 EXP. JT (E.J.) _____ EXPANSION JOINT
 E.W. _____ EACH WAY
 F.F. _____ FINISHED FLOOR
 F.O.M. _____ FACE OF MEMBER
 F.O.S. _____ FACE OF STEEL
 F.O.W. _____ FACE OF WALL
 GA _____ GAGE (UNIT OF MEASUREMENT)
 GALV _____ GALVANIZED
 G.S.N. _____ GENERAL STRUCTURAL NOTES
 GLB (GLULAM) _____ GLUED-LAMINATED BEAM
 HORIZ _____ HORIZONTAL REINFORCING
 IBC _____ INTERNATIONAL BUILDING CODE
 ICBO _____ INTERNATIONAL CONFERENCE OF BUILDING OFFICIALS
 I.F.W. _____ INSIDE FACE OF WALL
 I.O.D. _____ INTERPRETATION OF DRAWINGS
 K(KIP) _____ 1000 POUNDS
 KLF _____ KIPS PER LINEAR FOOT
 LBS (#) _____ POUNDS
 LGS _____ LIGHT GAGE STEEL
 LGSEA _____ LIGHT GAGE STEEL ENGINEERS ASSOCIATION
 L.O.D. _____ LOCATION OF DETAILS
 LL _____ LIVE LOAD
 LLH _____ LONG LEG HORIZONTAL
 LLV _____ LONG LEG VERTICAL
 MAS _____ MASONRY
 MAS C.J. _____ MASONRY CONTROL JOINT
 MAX _____ MAXIMUM
 MBMA _____ METAL BUILDING MANUFACTURERS ASSOCIATION
 MECH'L _____ MECHANICAL
 MFR('S) _____ MANUFACTURER('S)
 MIN _____ MINIMUM
 N/A _____ NOT APPLICABLE
 N.T.S. _____ NOT TO SCALE
 O.C. _____ ON CENTER
 O.F.W. _____ OUTSIDE FACE OF WALL
 OPP _____ OPPOSITE
 OSHA _____ OCCUPATIONAL SAFETY AND HEALTH ADMINISTRATION

PCI _____ PRECAST/PRESTRESSED CONCRETE INSTITUTE
 P.C. _____ PRECAST CONCRETE
 PLF _____ POUNDS PER LINEAR FOOT
 ± _____ PLUS OR MINUS
 PREFAB _____ PREFABRICATED
 PSF _____ POUNDS PER SQUARE FOOT
 PSI _____ POUNDS PER SQUARE INCH
 PTI _____ POST-TENSIONING INSTITUTE
 REINF _____ REINFORCING
 SDI _____ STEEL DECK INSTITUTE
 SLH _____ SHORT LEG HORIZONTAL
 SLV _____ SHORT LEG VERTICAL
 SJI _____ STEEL JOIST INSTITUTE
 SIM _____ SIMILAR
 SQ. _____ SQUARE
 SSMA _____ STEEL STUD MANUFACTURERS ASSOCIATION
 STD _____ STANDARD
 STL _____ STEEL
 TL _____ TOTAL LOAD
 T.O.B. _____ TOP OF BEAM
 T.O.C.T. _____ TOP OF CONCRETE TOPPING
 T.O.D. _____ TOP OF DECK
 T.O.F. _____ TOP OF FOOTING
 T.O.L. _____ TOP OF LEDGER
 T.O.M. _____ TOP OF MASONRY
 T.O.P. _____ TOP OF PLATE
 T.O.P.C. _____ TOP OF PRECAST CONCRETE
 T.O.S. _____ TOP OF STEEL
 T.O.W. _____ TOP OF WALL
 TPI _____ TRUSS PLATE INSTITUTE
 TYP _____ TYPICAL
 T&G _____ TONGUE AND GROOVE
 UBC _____ UNIFORM BUILDING CODE
 U.N.O. _____ UNLESS NOTED OTHERWISE
 VERT _____ VERTICAL REINFORCING
 WCLA _____ WEST COAST LUMBER ASSOCIATION
 WCLIB _____ WEST COAST LUMBER INSPECTION BUREAU
 W.W.F. _____ WELDED WIRE FABRIC
 WWPA _____ WESTERN WOOD PRODUCTS ASSOCIATION
 W/ _____ WITH
 W/C _____ WATER TO CEMENT RATIO
 W/O _____ WITHOUT

DETAIL NO.
2265-7

**City of Scottsdale
Standard Details**

APPROVED BY:
**Scottsdale Standards &
Specifications Committee**

BUS SHELTER

DETAIL NO.
2265-7

REVISED 4/19/05

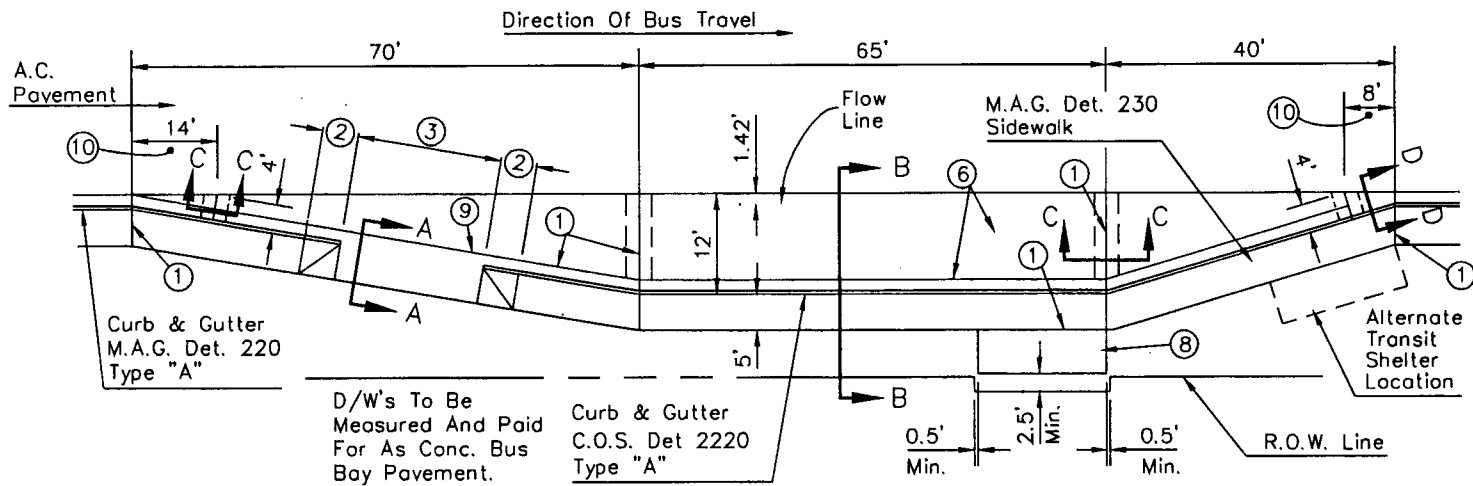

PLAN VIEW

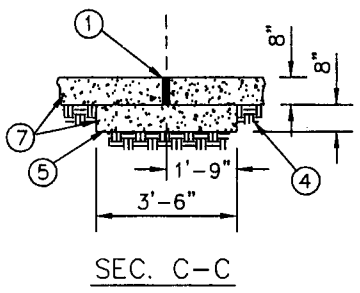

SEC. C-C

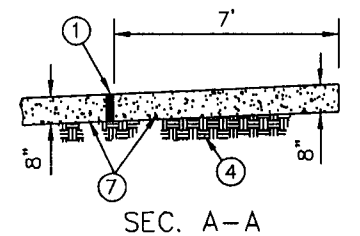

SEC. A-A

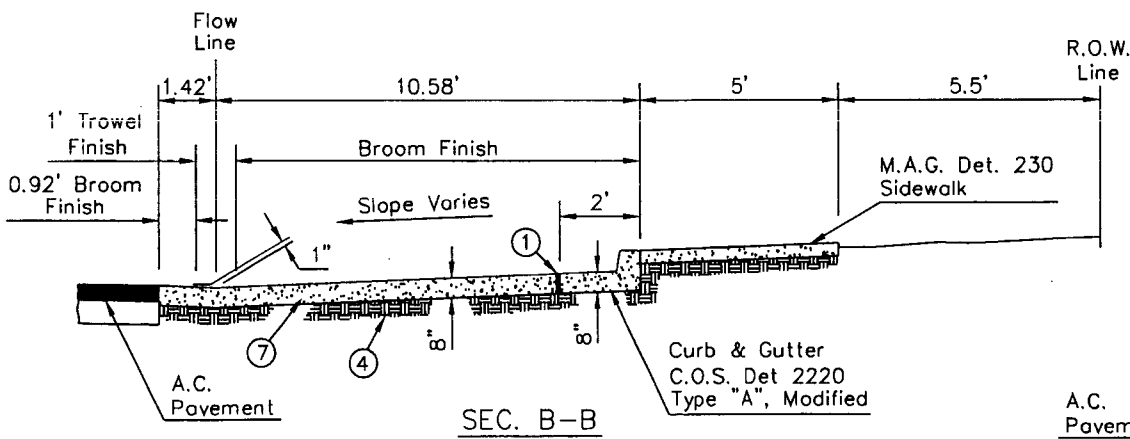

SEC. B-B

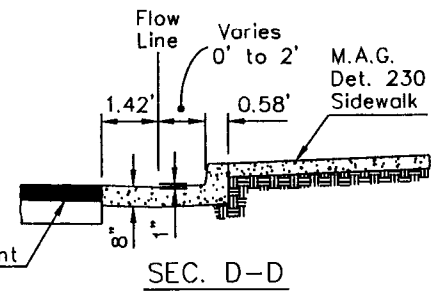

SEC. D-D

- ① 1/2" BITUMINOUS PREFORMED EXPANSION JOINT FILLER, A.S.T.M. D-1751 PER MAG SEC. 729, INSTALL PER COS SEC. 340.3
- ② TRANSITION CURB FACE FROM 6" TO 0" HEIGHT IN 5'
- ③ D/W WIDTHS & LOCATIONS VARY, SEE PLANS. MAINTAIN 10' MIN. CLEARANCE BETWEEN DRIVEWAYS AND SHELTER PAD. WHEN DRIVEWAY WIDTH EXCEEDS 22', PROVIDE A CONTRACTION JOINT ON D/W & SUBGRADE PREPARATION PER MAG SECTION 301.
- ④ CONCRETE PAD TO BE POURED SEPARATELY FROM CONCRETE BUS BAY PAVEMENT.
- ⑤ CONTRACTION JOINTS IN THE BUS BAY PAVEMENT SHALL MATCH THOSE IN THE CURB.
- ⑥ CONCRETE SHALL BE CLASS "A" PER MAG SECTION 725
- ⑦ TRANSIT SHELTER PAD, PER COS STD DETAIL 2269.
- ⑧ NEW CONCRETE D/W TO BE POURED WITH BUS BAY PAVEMENT.
- ⑨ CURB & GUTTER TO BUS BAY PAVEMENT TRANSITION.

DETAIL NO. **2266-1** **City of Scottsdale**
Standard Details

APPROVED BY:
Scottsdale Standards & Specifications Committee

CLOSED END BUS BAY - TYPE "A"

DETAIL NO. **2266-1**

REVISED 4/19/05

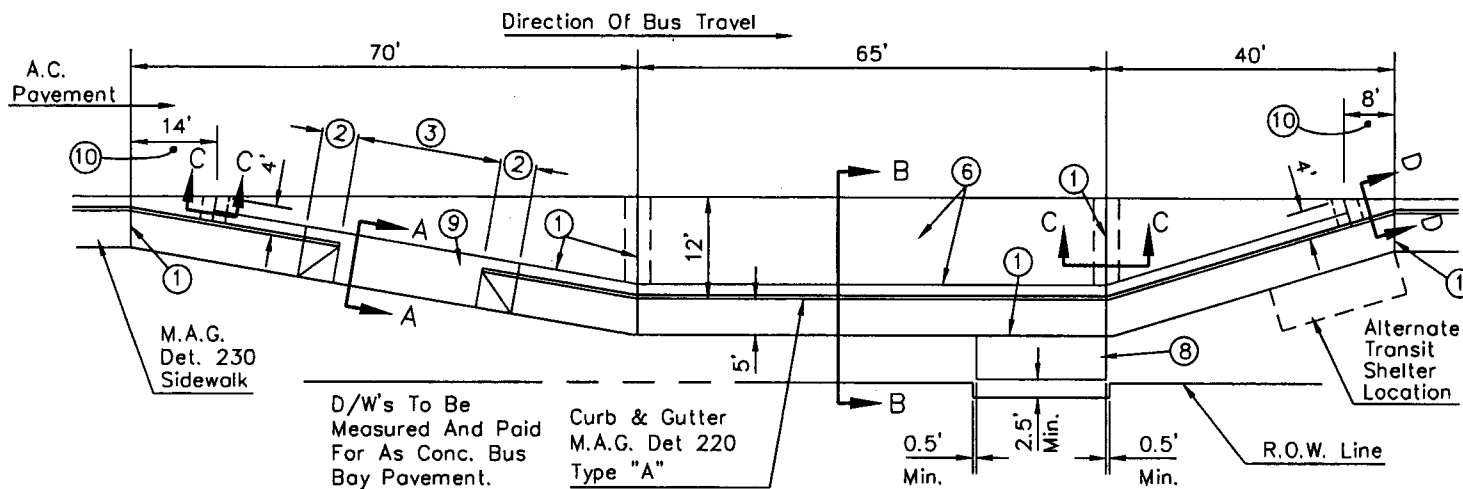

PLAN VIEW

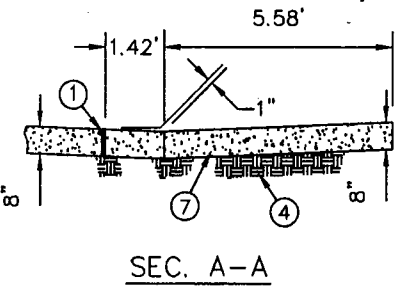

SEC. A-A

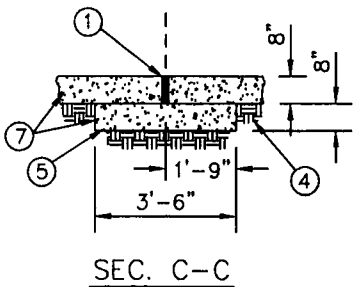

SEC. C-C

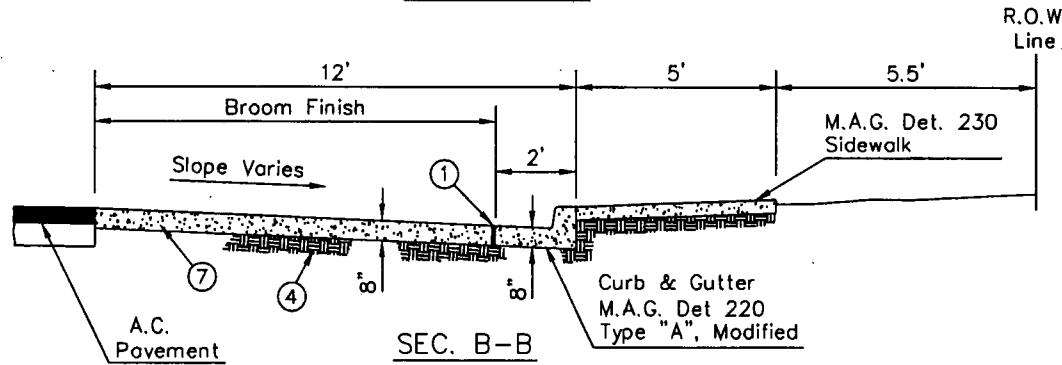

SEC. B-B

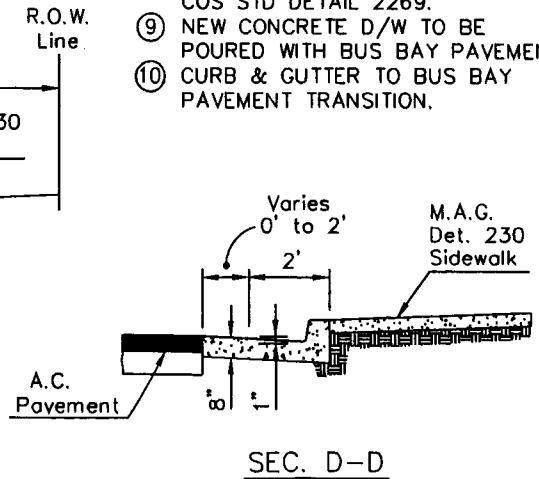

SEC. D-D

- ① 1/2" BITUMINOUS PREFORMED EXPANSION JOINT FILLER, A.S.T.M. D-1751 PER MAG SECTION 729.
- ② TRANSITION CURB FACE FROM 6" TO 0" HEIGHT IN 5'
- ③ D/W WIDTHS & LOCATIONS VARY, SEE PLANS. MAINTAIN 10' MIN. CLEARANCE BETWEEN DRIVEWAYS AND SHELTER PAD. WHEN DRIVEWAY WIDTH EXCEEDS 22', PROVIDE A CONTRACTION JOINT ON D/W CL.
- ④ SUBGRADE PREPARATION PER MAG SECTION 301.
- ⑤ CONCRETE PAD TO BE POURED SEPARATELY FROM CONCRETE BUS BAY PAVEMENT.
- ⑥ CONTRACTION JOINTS IN THE BUS BAY PAVEMENT SHALL MATCH THOSE IN THE CURB.
- ⑦ CONCRETE SHALL BE CLASS "A" PER MAG SECTION 725
- ⑧ TRANSIT SHELTER PAD, PER COS STD DETAIL 2269.
- ⑨ NEW CONCRETE D/W TO BE POURED WITH BUS BAY PAVEMENT.
- ⑩ CURB & GUTTER TO BUS BAY PAVEMENT TRANSITION.

DETAIL NO. **2266-2** City of Scottsdale Standard Details APPROVED BY: **Scottsdale Standards & Specifications Committee**

CLOSED END BUS BAY - TYPE "B"

DETAIL NO. **2266-2**

REVISED 1/4/93

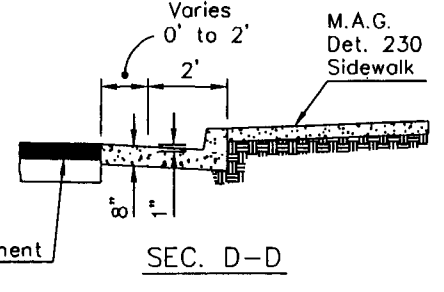
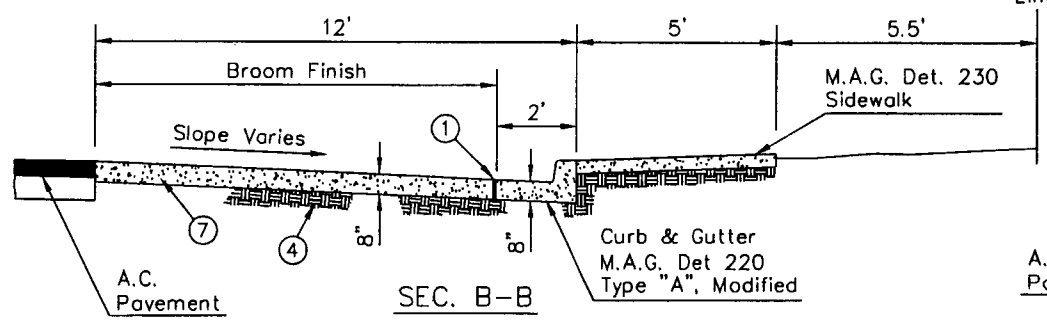
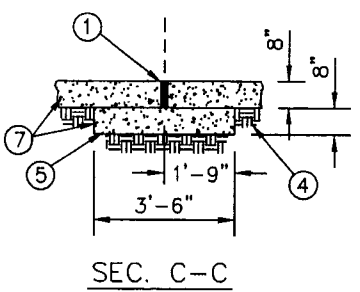
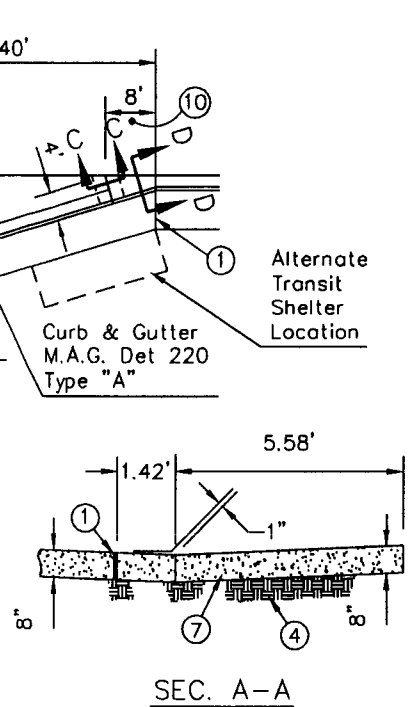
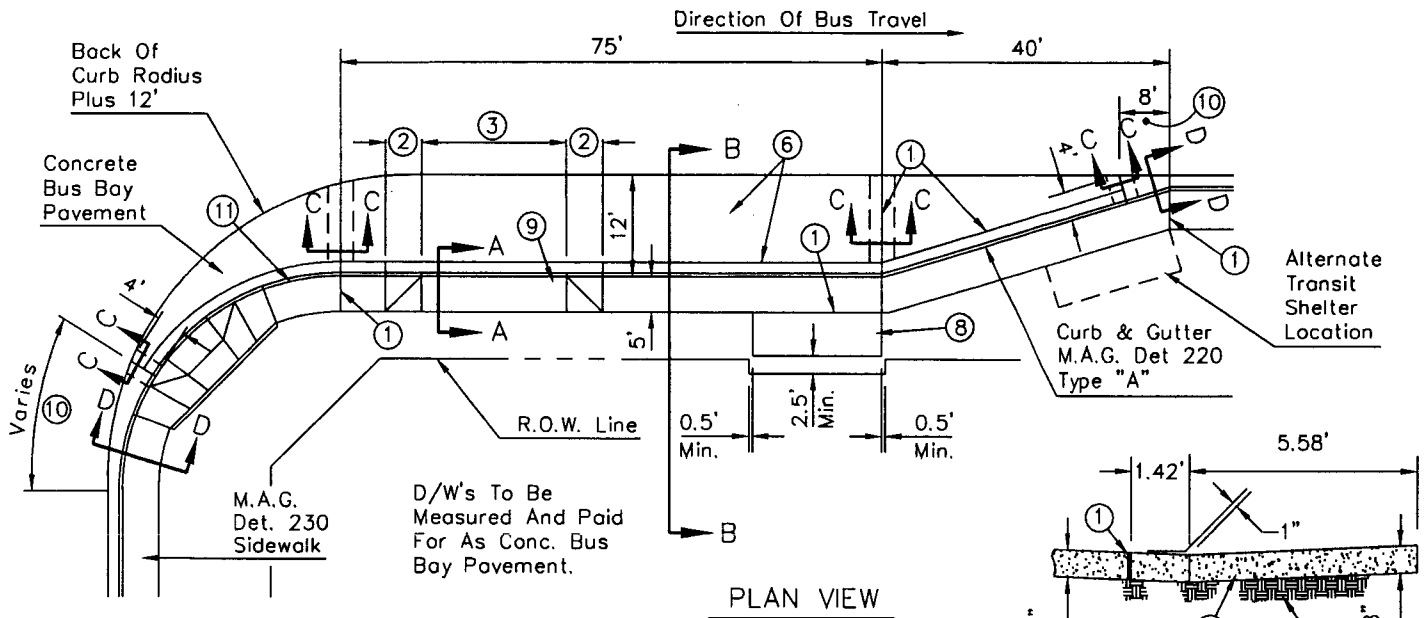

- ① 1/2" BITUMINOUS PREFORMED EXPANSION JOINT FILLER, A.S.T.M. D-1751 PER MAG SECTION 729.
- ② TRANSITION CURB FACE FROM 6" TO 0" HEIGHT IN 5'
- ③ D/W WIDTHS & LOCATIONS VARY, SEE PLANS. MAINTAIN 10' MIN. CLEARANCE BETWEEN DRIVEWAYS AND SHELTER PAD. WHEN DRIVEWAY WIDTH EXCEEDS 22', PROVIDE A CONTRACTION JOINT ON D/W C/L.
- ④ SUBGRADE PREPARATION PER MAG SECTION 301.
- ⑤ CONCRETE PAD TO BE POURED SEPARATELY FROM CONCRETE BUS BAY PAVEMENT.
- ⑥ CONTRACTION JOINTS IN THE BUS BAY PAVEMENT SHALL MATCH THOSE IN THE CURB.
- ⑦ CONCRETE SHALL BE CLASS "A" PER MAG SECTION 725
- ⑧ TRANSIT SHELTER PAD, PER COS STD DETAIL 2269.
- ⑨ NEW CONCRETE D/W TO BE POURED WITH BUS BAY PAVEMENT. CURB & GUTTER TO BUS BAY PAVEMENT TRANSITION.
- ⑩ CURB & GUTTER TO BUS BAY PAVEMENT TRANSITION.
- ⑪ CURB RADIUS AS SHOWN ON THE PLANS

DETAIL NO. 2267

City of Scottsdale Standard Details

APPROVED BY: Scottsdale Standards & Specifications Committee

FAR - SIDE BUS BAY

DETAIL NO. 2267

REVISED 7/1/97

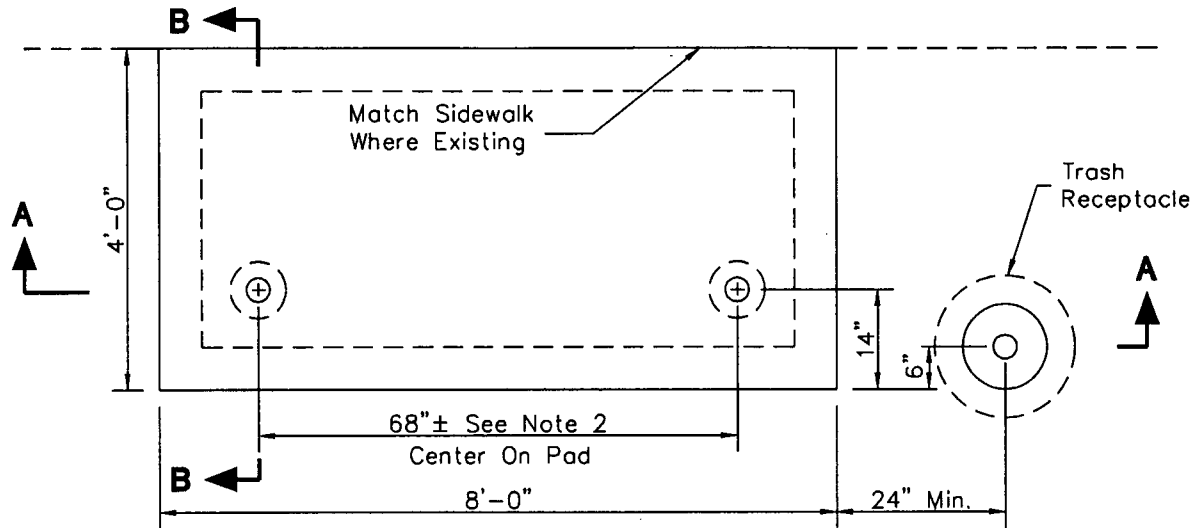

BASE SLAB PLAN

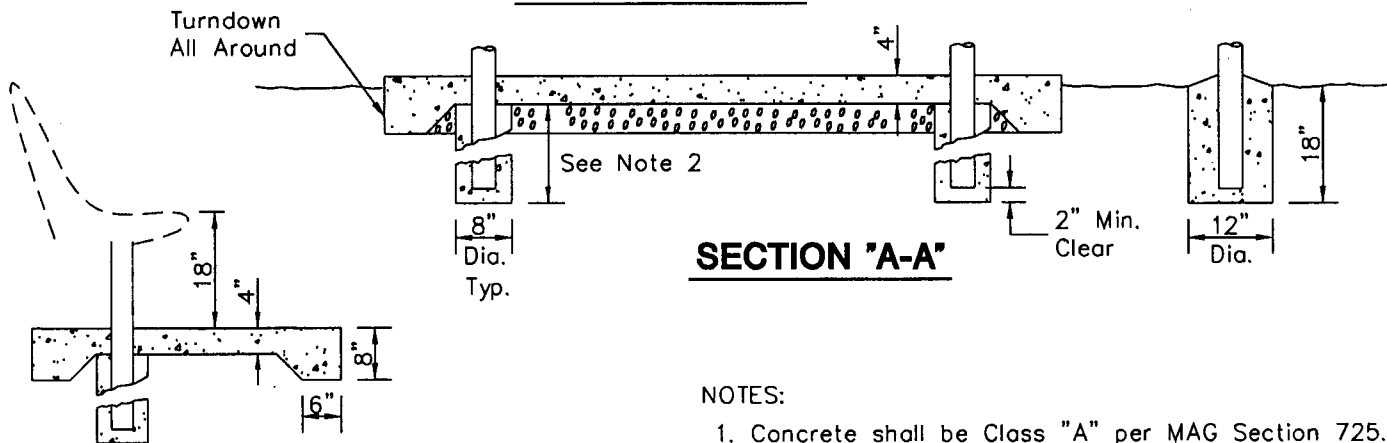

SECTION "A-A"

SECTION "B-B"

NOTES:

1. Concrete shall be Class "A" per MAG Section 725. Slab surface shall be trowel finish with salt pitted appearance and random sweat. Use integral color when specified on the plans.

2. Dimensions may vary with bench style - Verify and adjust to provide clearance and bench height shown.

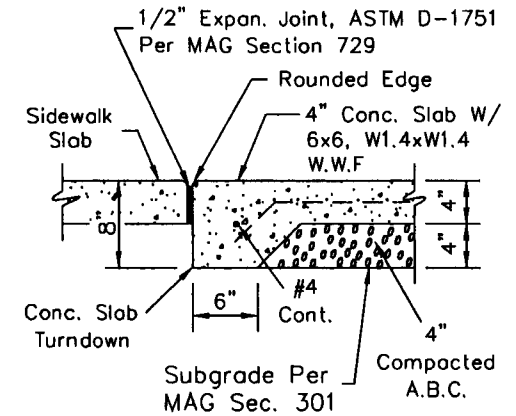

SLAB EDGE AT SIDEWALK

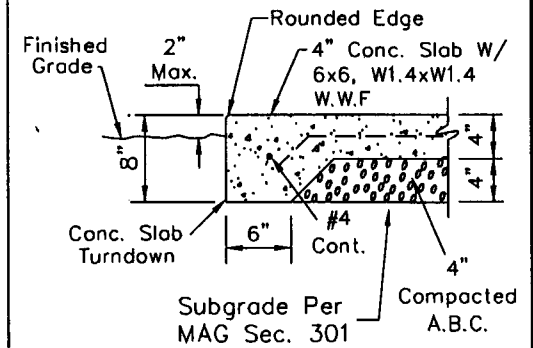

SLAB EDGE AT GRADE

DETAIL NO.
2268

**City of Scottsdale
Standard Details**

APPROVED BY:
**Scottsdale Standards &
Specifications Committee**

**BASE SLAB AND FOUNDATIONS FOR
BUS STOP BENCH AND RECEPTACLES**

DETAIL NO.
2268

REVISED 7/1/97

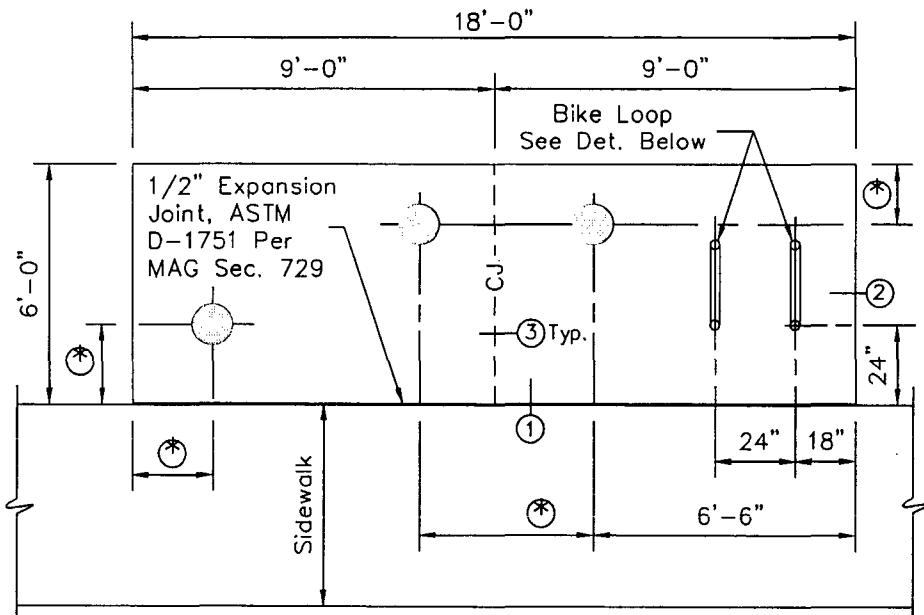

SHELTER SLAB PLAN

NOTES:

1. Concrete shall be Class "A" per MAG Sec. 725. Slab surface shall be trowel finish with salt pitted appearance and random sweat. Use integral color when specified on the plans.
2. "⊛" Blockout locations for bench and trash receptacle as shown on Plans or specified by the Engineer.

LEGEND

--- CJ --- Control Joints

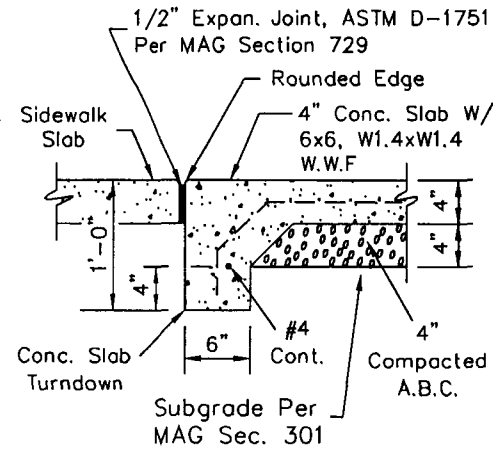
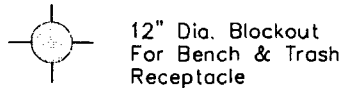

① SLAB EDGE AT SIDEWALK

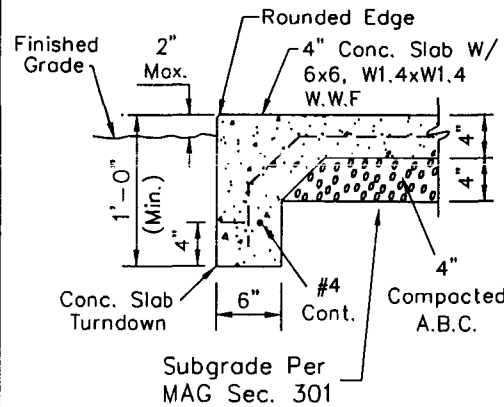

② SLAB EDGE AT GRADE

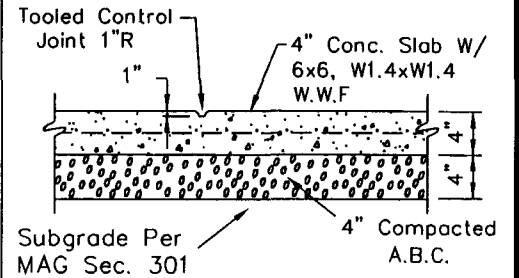

③ SLAB CONTROL JOINTS

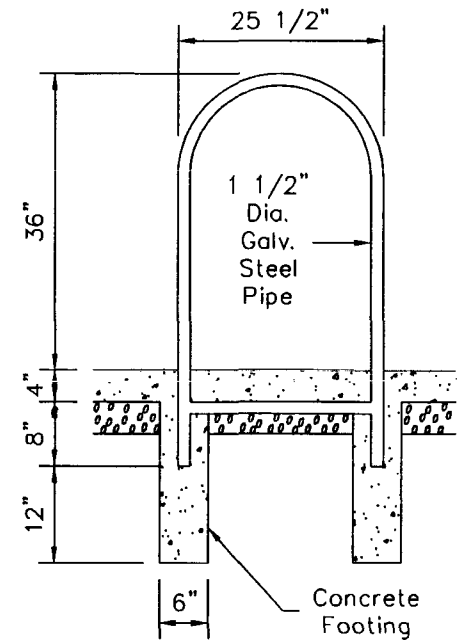

BIKE LOOP DETAIL

DETAIL NO. 2269

City of Scottsdale
Standard Details

APPROVED BY:
Scottsdale Standards & Specifications Committee

TRANSIT SHELTER PAD

DETAIL NO. 2269

REVISED 2/27/01

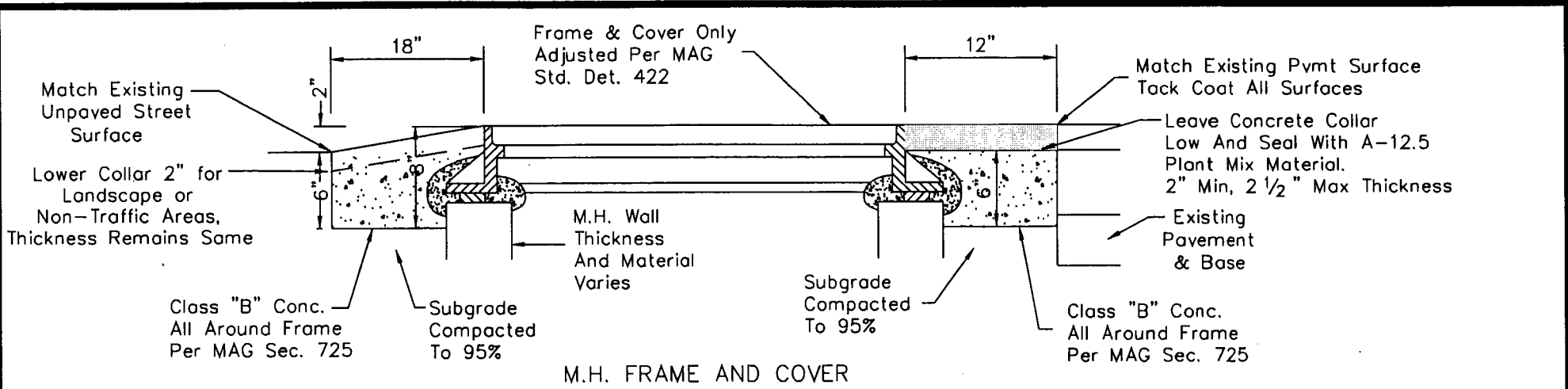

UNPAVED LOCATIONS

PAVED LOCATIONS

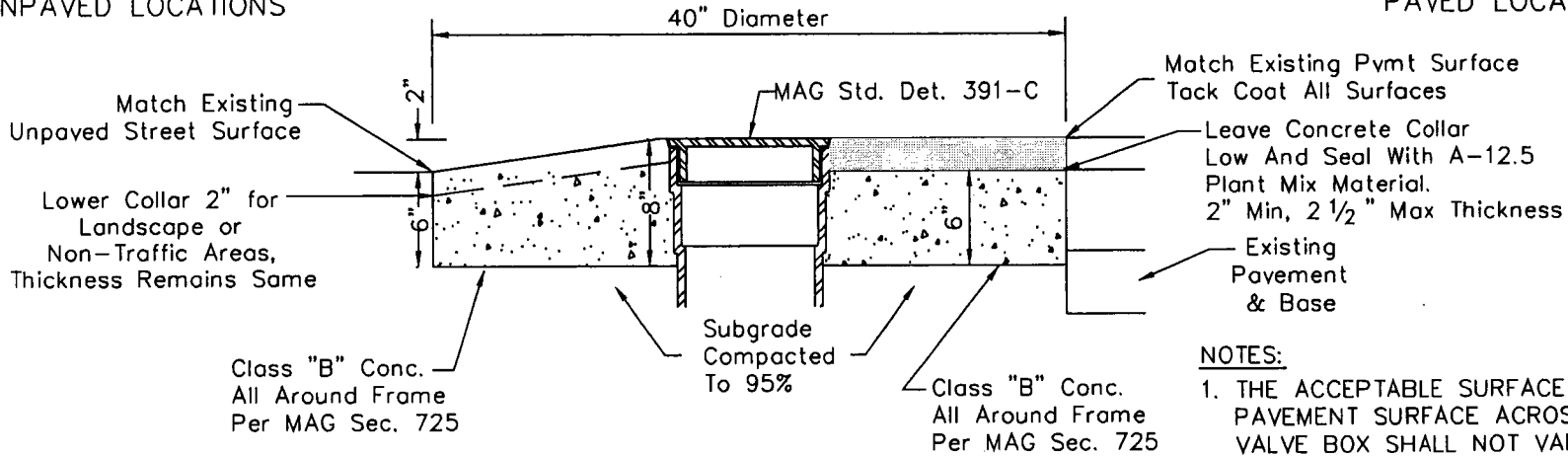

NOTES:

1. THE ACCEPTABLE SURFACE PROFILE FROM THE PAVEMENT SURFACE ACROSS THE MANHOLE OR VALVE BOX SHALL NOT VARY MORE THAN 1/4 INCH FROM THE LOWER EDGE OF A 12 FOOT STRAIGHTEDGE WHEN THE STRAIGHTEDGE IS PLACED PARALLEL AND PERPENDICULAR TO THE CENTERLINE OF THE ROADWAY.

DETAIL NO.
2270

**City of Scottsdale
Standard Details**

APPROVED BY:
**Scottsdale Standards &
Specifications Committee**

FRAME & COVER GRADE ADJUSTMENT

DETAIL NO.
2270

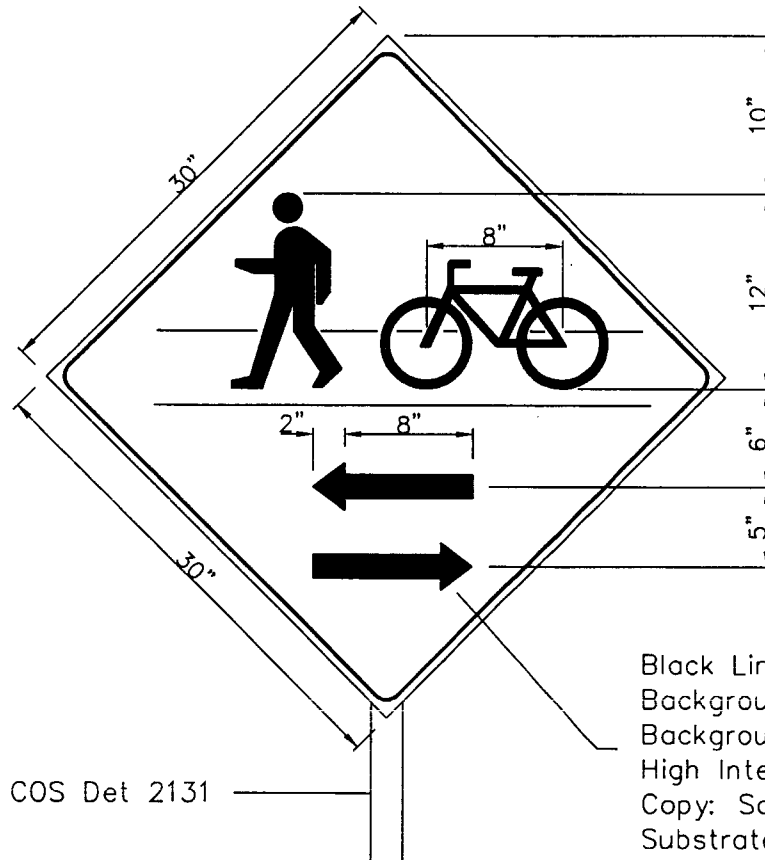

Install Per COS Det 2131

Black Lines On Yellow Reflectorized
Background (Typ.)
Background: Super Engineer Grade Or
High Intensity Sheeting
Copy: Same As Above
Substrate: 0.080 Gauge Treated Aluminum

MULTI-USE PATH CROSSING SIGN

DETAIL NO.
2281
City of Scottsdale
Standard Details

APPROVED BY:
Scottsdale Standards &
Specifications Committee

MULTI-USE PATH CROSSING SIGN

DETAIL NO.
2281

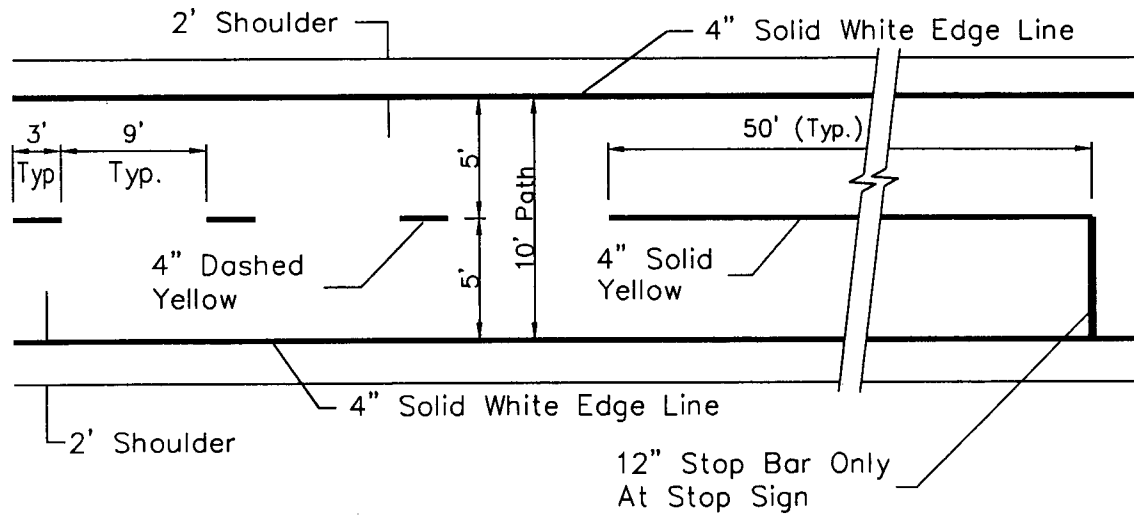

MULTI-USE PATH STRIPING DETAILS

NOTE:

Striping shall be reflectorized paint with glass beads per COS Specifications Sec. 402.2

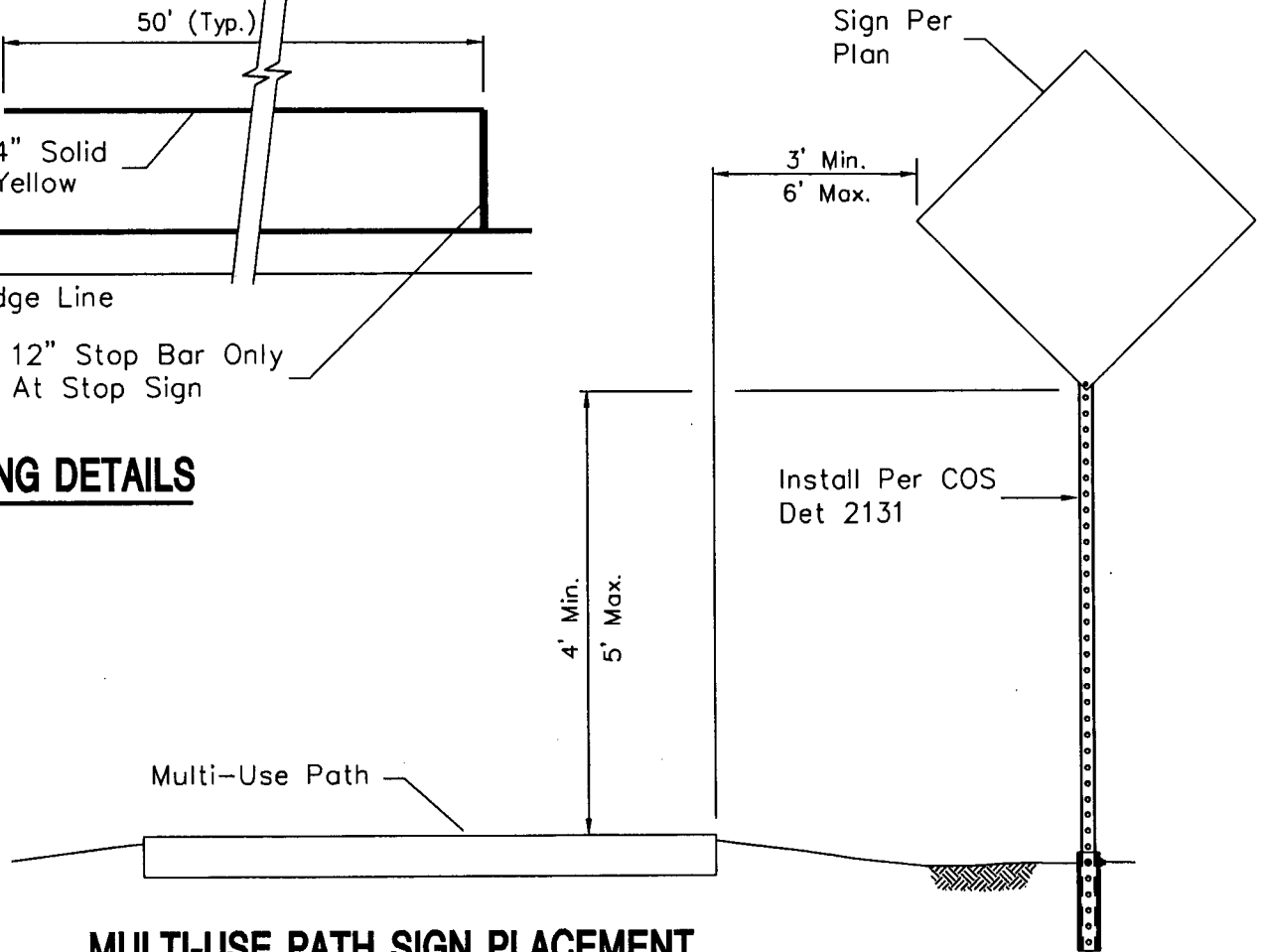

MULTI-USE PATH SIGN PLACEMENT

DETAIL NO.
2282

**City of Scottsdale
Standard Details**

APPROVED BY:
**Scottsdale Standards &
Specifications Committee**

MULTI-USE PATH STRIPING AND SIGNING

DETAIL NO.
2282

* See Shoulder Detail

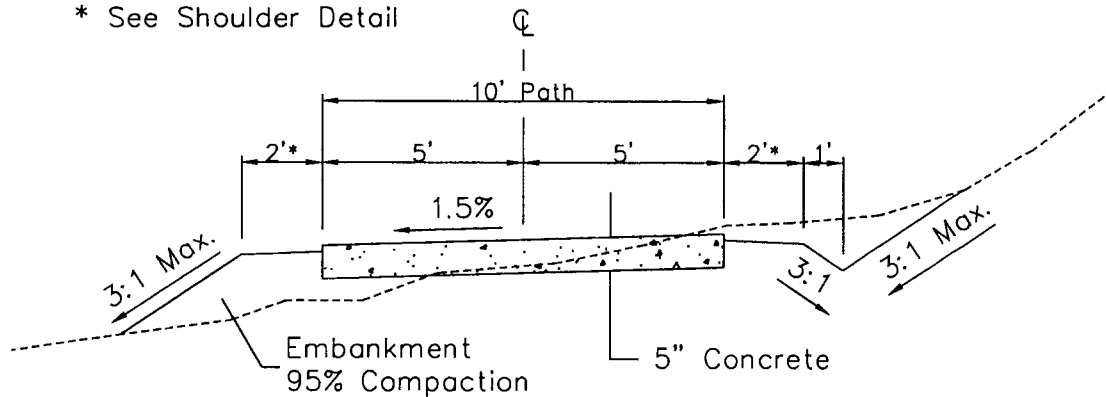

MULTI-USE PATH DETAIL

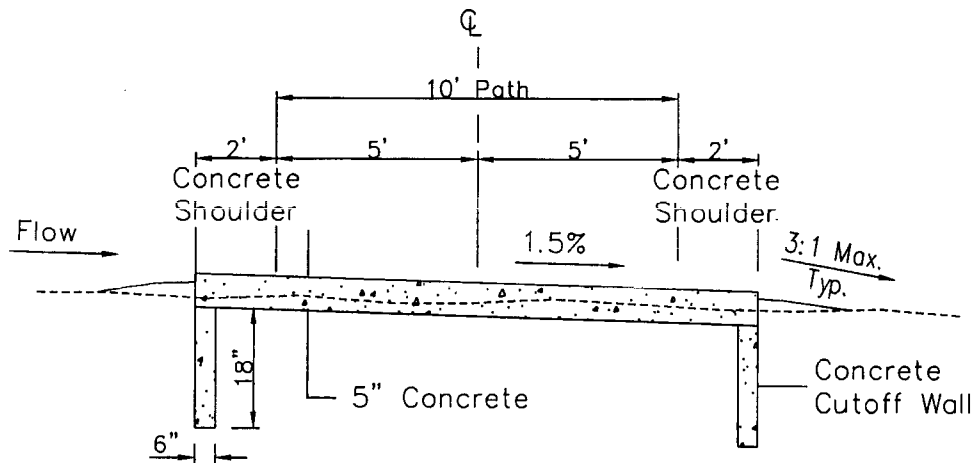

MULTI-USE PATH WET AREA CROSSING

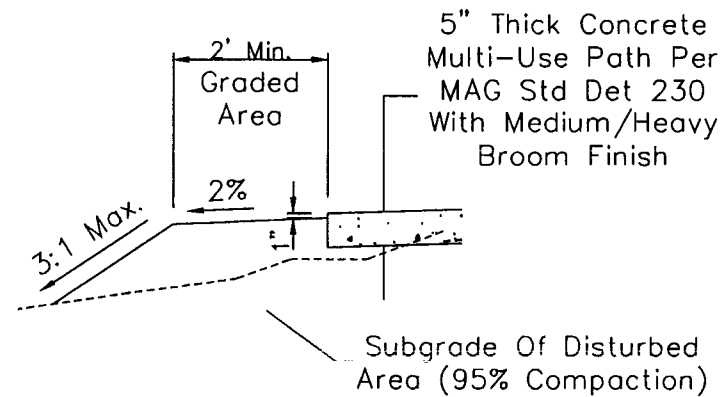

SHOULDER DETAIL

Note: A 3' x 3' Test Panel Shall Be Poured and the finish approved by COS Bicycle Staff At (480)312-7696.

REVISED: 2/26/01

DETAIL NO. **2283** City of Scottsdale Standard Details

APPROVED BY: **Scottsdale Standards & Specifications Committee**

MULTI-USE PATH DETAILS

DETAIL NO. **2283**

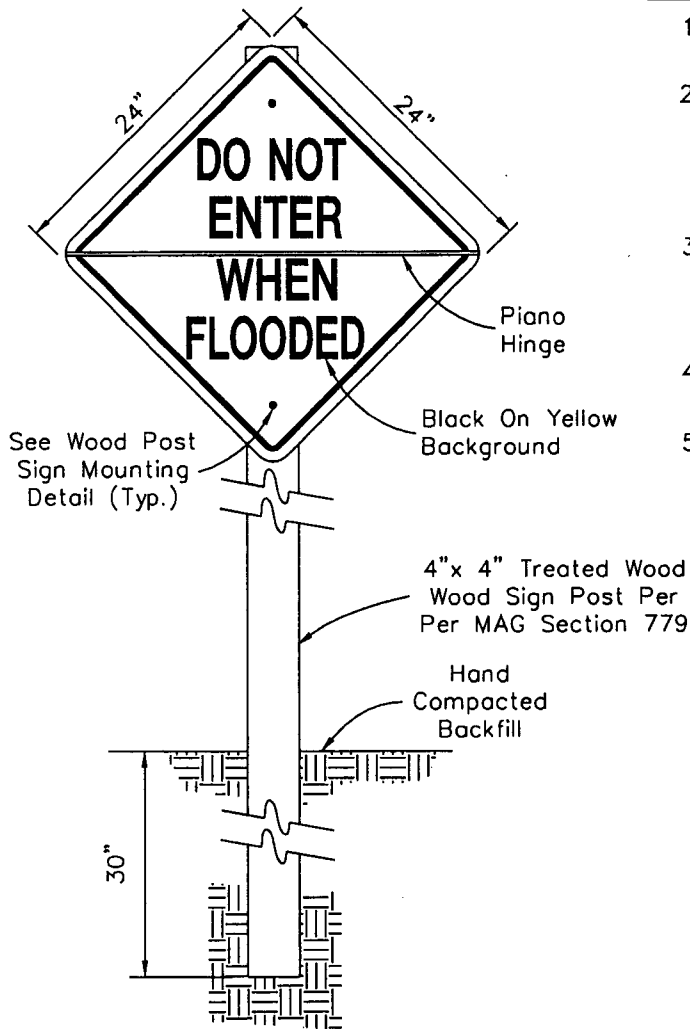

NOTES:

1. Signs shall conform to C.O.S. Supplemental Specifications, Section 402.3.
2. Signs to be mounted on square perforated tubing per C.O.S. Std Det 2131 within C.O.S. Right-of-Way. Treated wood post may be used for trail markers located outside C.O.S. Right-of Way.
3. Legends and borders shall be vinyl sheeting on a reflectorized vinyl background (colors as noted) unless otherwise approved by the City of Scottsdale.
4. Sign height and placement shall conform to C.O.S. Std. Det. 2282.
5. For additional information regarding sign fabrication, contact the City of Scottsdale Sign Shop, 312-5646.

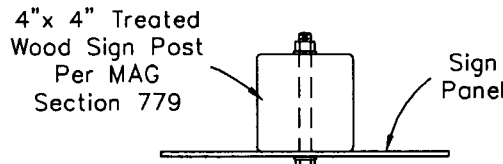

Fasten With (2) 1/2" x 2" Lag Screws With (2) Flat Washers or (2) 1/2" x 4 1/2" Bolts With (4) Flat Washers, Burr Threads And Nuts With Center Punch.

WOOD POST SIGN MOUNTING DETAIL

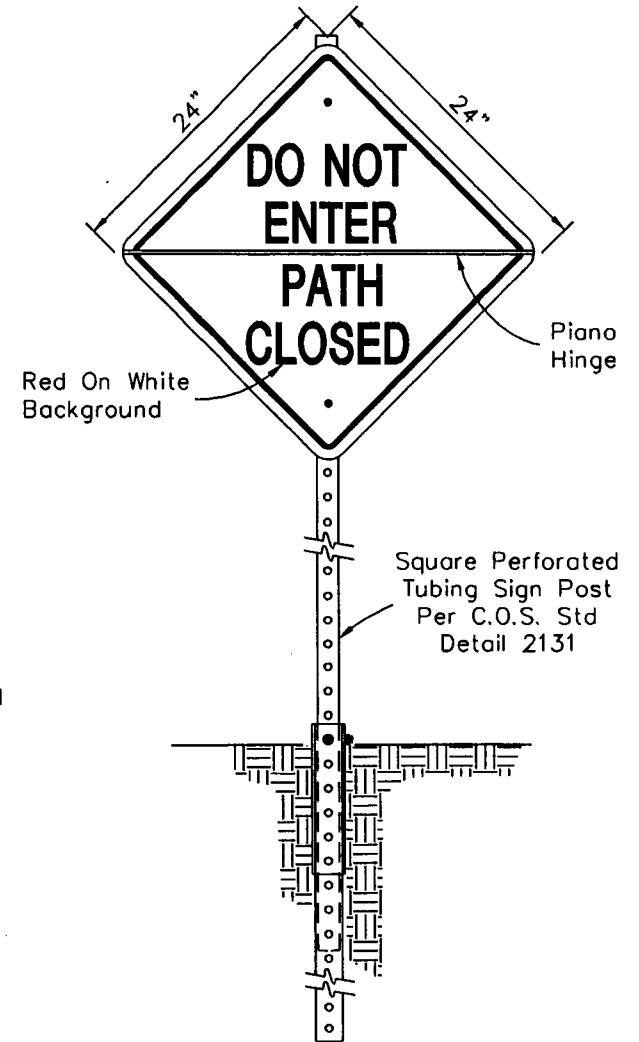

DETAIL NO. 2284	City of Scottsdale Standard Details	APPROVED BY: Scottsdale Standards & Specifications Committee	MULTI-USE PATH WET CROSSING SIGN	DETAIL NO. 2284
---------------------------	--	--	---	---------------------------

REVISED 4/07/05

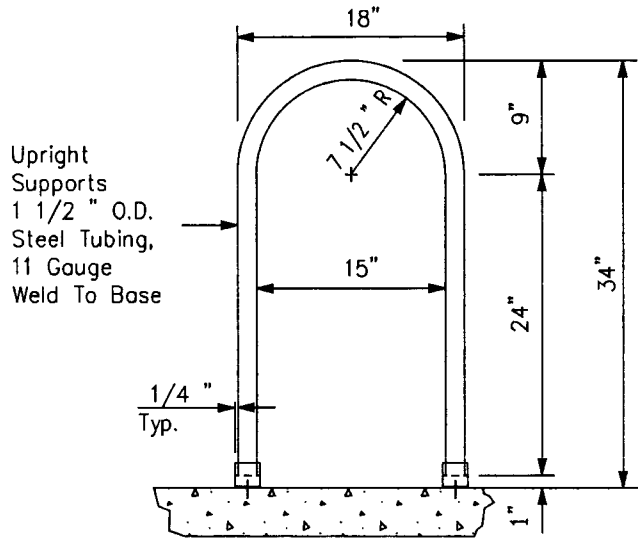

1/8" x 2" x 2" x 0'-2"
Angle Anchor Brackets
w/ 1/2" ϕ Hole. Weld
To Base. (4 Req'd)

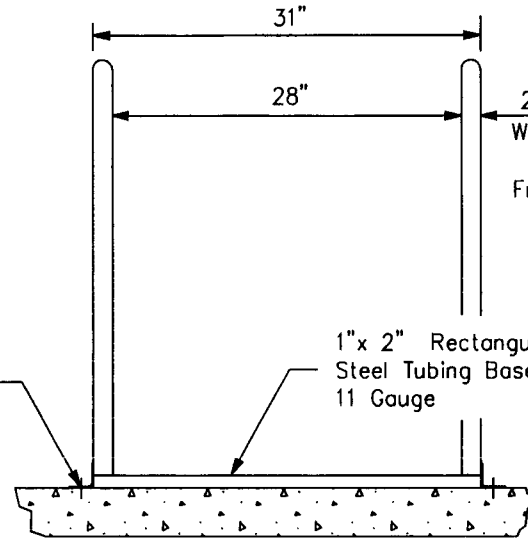

2' Min. Clearance From
Walls Or Obstructions On
Both Sides And Back.
Front To Have A 6' Min.
Clear Area.

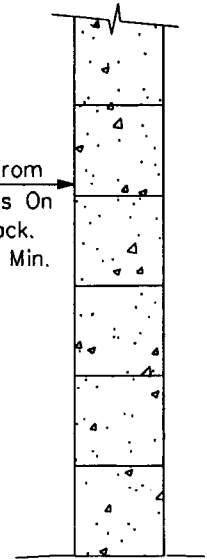

NOTES:

1. Double rack holds 4 bicycles.
2. Finish to be weather resistant, baked-on powder polymer coating.
3. Anchor rack to concrete w/ 3/8" ϕ x 2 1/2" wedge anchors and tamper resistant or welded nuts, (4 Req'd) or set tubing 12" below grade in 24" deep x 6" wide concrete footing.
4. Concrete base may be covered with turf or decomposed granite.
5. Placement of bicycle rack shall be convenient to main entrance and in a highly visible area.

1/8" x 2" x 2" x 0'-2"
Angle Anchor Brackets
w/ 1/2" ϕ Hole. Weld
To Base. (4 Req'd)

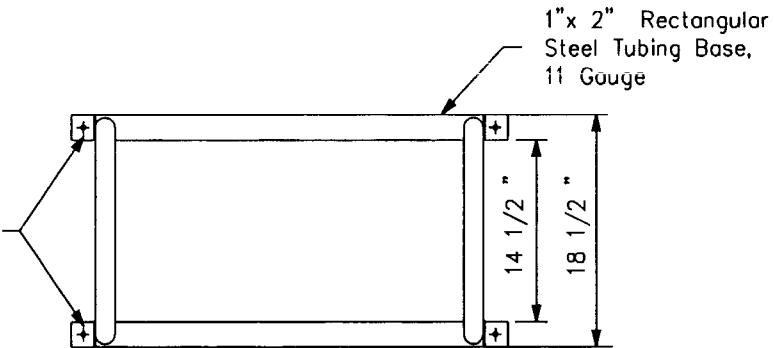

DETAIL NO.
2285

**City of Scottsdale
Standard Details**

APPROVED BY:

DOUBLE BICYCLE RACK

DETAIL NO.
2285

REVISED 5/4/05

CURVE DATA - TO BACK OF CURB			
CURVE	RADIUS	LENGTH	DELTA
C1	0.50'	1.43'	164°12'35"
C2	80.00'	22.05'	15°47'25"
C3	3.00'	9.42'	180°00'00"

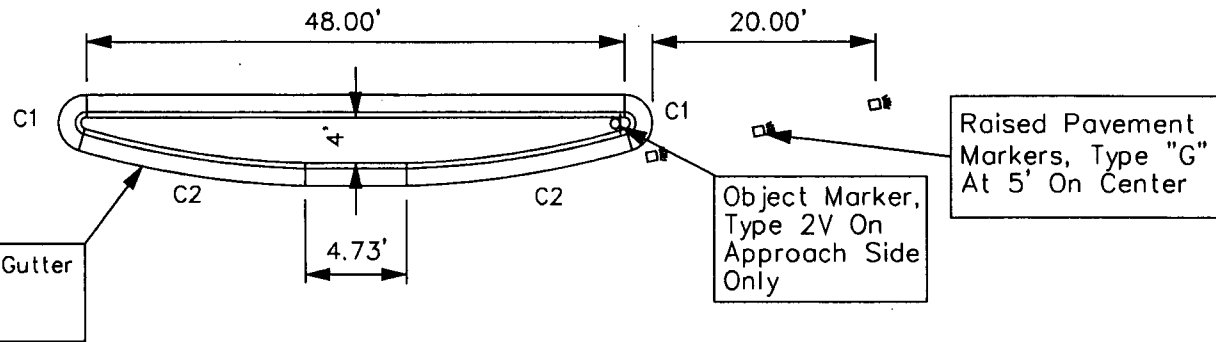

SIDE ISLAND DETAIL

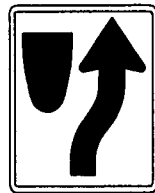

R4-7
24" x 30"

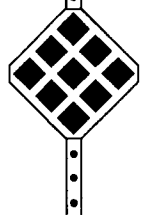

OM1-2
18" x 18"

Signage Per COS
Standard Detail
2133 or as
Specified.

R4-7 Sign And Object Marker
At Both Ends. For A Series Of
Medians Place R4-7 Sign At
Approach End Of First Median
Only.

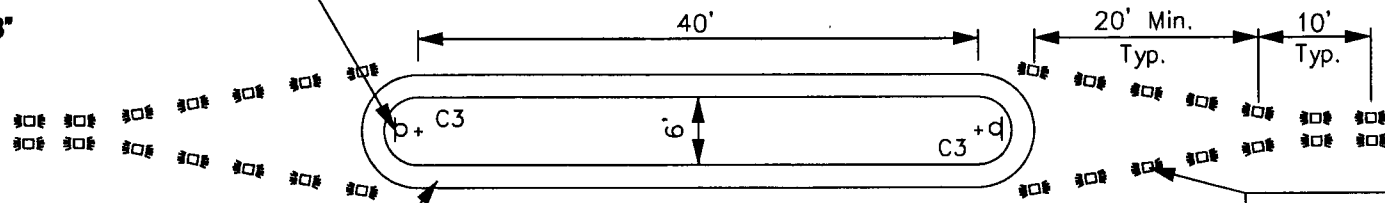

MEDIAN ISLAND DETAIL

Raised Pavement
Markers, Type "D"
At 5' On Center.
Both Ends

DETAIL NO.
2290

**City of Scottsdale
Standard Details**

APPROVED BY:
**Scottsdale Standards &
Specifications Committee**

MEDIAN ISLAND DETAILS

DETAIL NO.
2290

REVISED 5/4/05

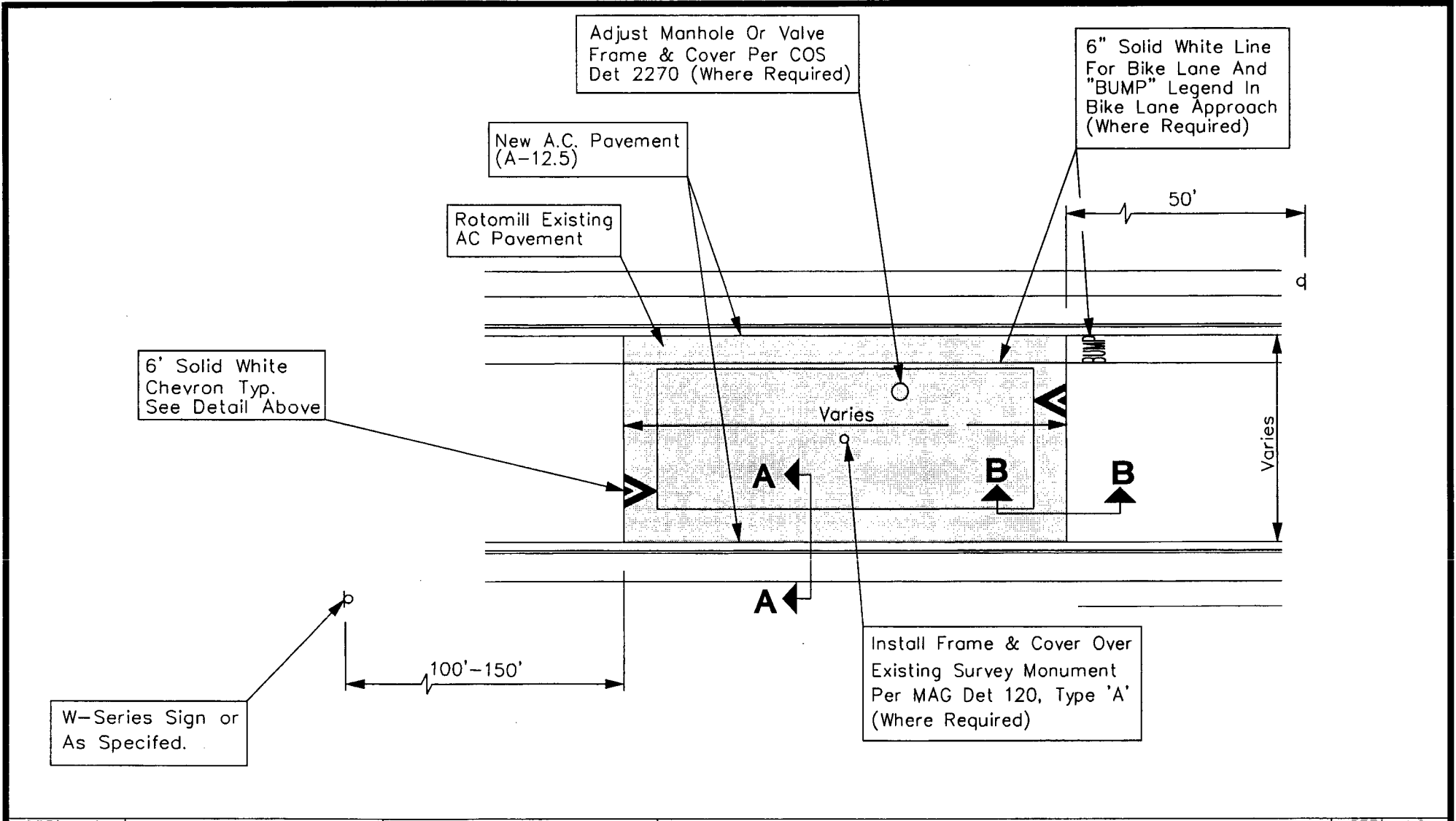

DETAIL NO. 2292-1	City of Scottsdale Standard Details	APPROVED BY: Scottsdale Standards & Specifications Committee	SPEED TABLE DETAILS	DETAIL NO. 2292-1
-----------------------------	--	--	----------------------------	-----------------------------

REVISED 5/4/05

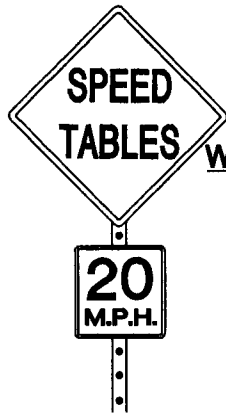

Warning Sign
30" x 30"

W13-1
18" x 18"

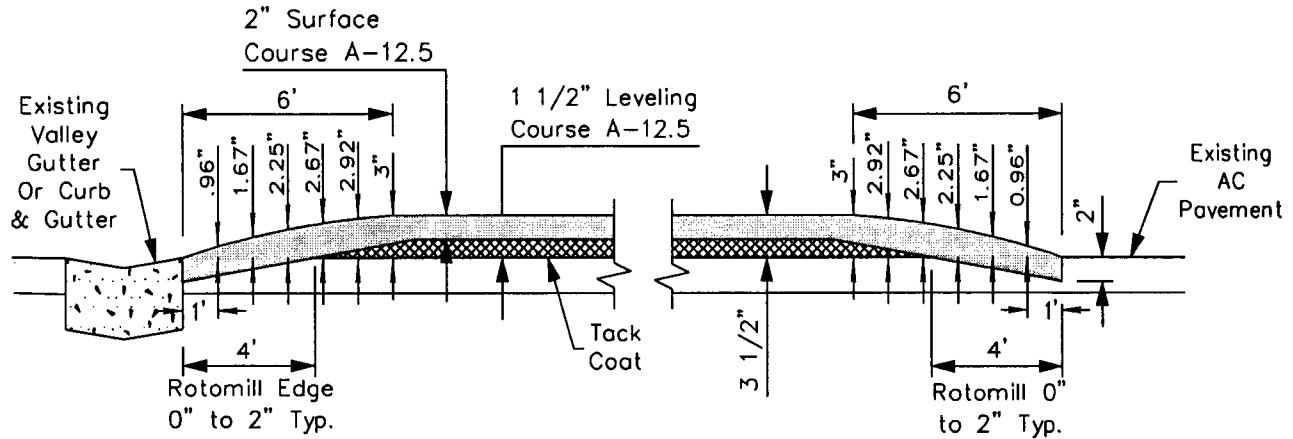

SECTION A-A
MATCH EX. CONCRETE
TYPICAL ALL LOCATIONS

SECTION B-B
MATCH EX. AC PAVEMENT
TYPICAL ALL LOCATIONS

Edge of Pavement
Or Travel Lane

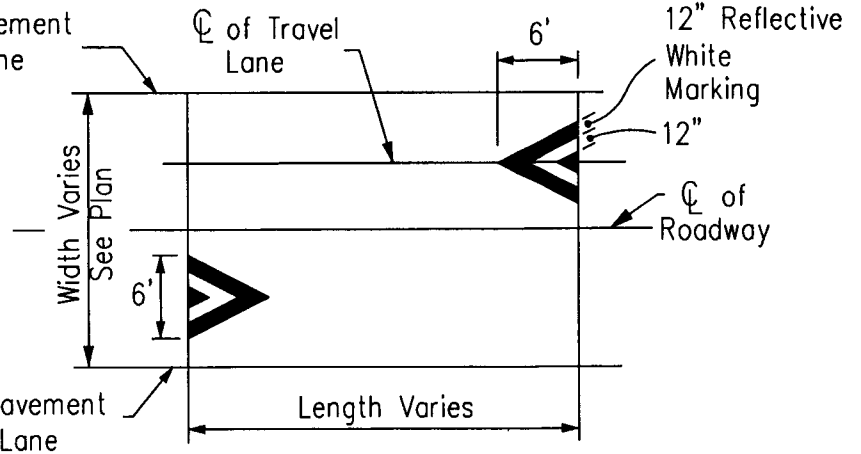

CHEVRON DETAIL

DETAIL NO.
2292-2

City of Scottsdale
Standard Details

APPROVED BY:
Scottsdale Standards & Specifications Committee

SPEED TABLE DETAILS

DETAIL NO.
2292-2

REVISED 4/29/05

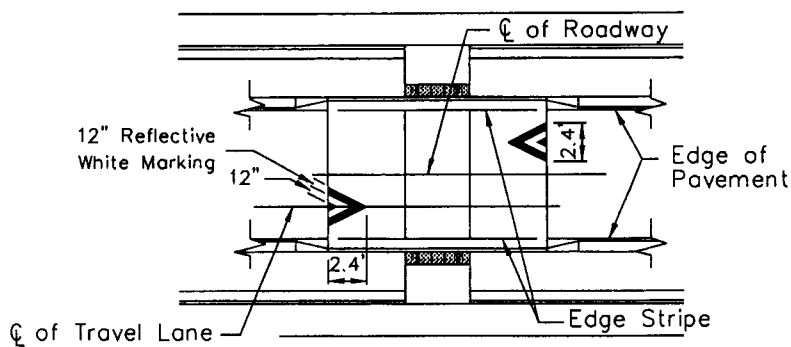

Chevron Detail

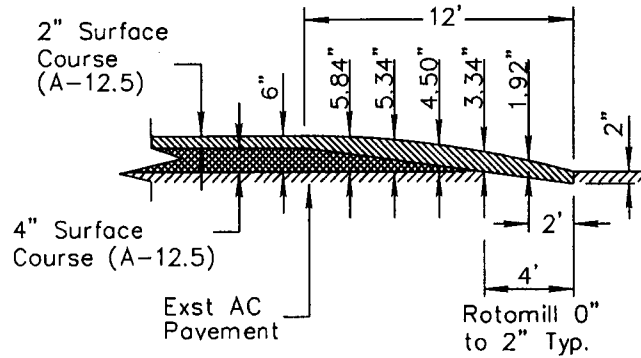

Section A-A

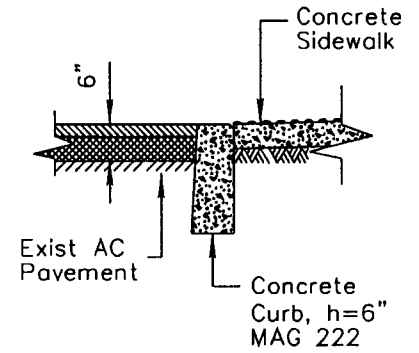

Section B-B

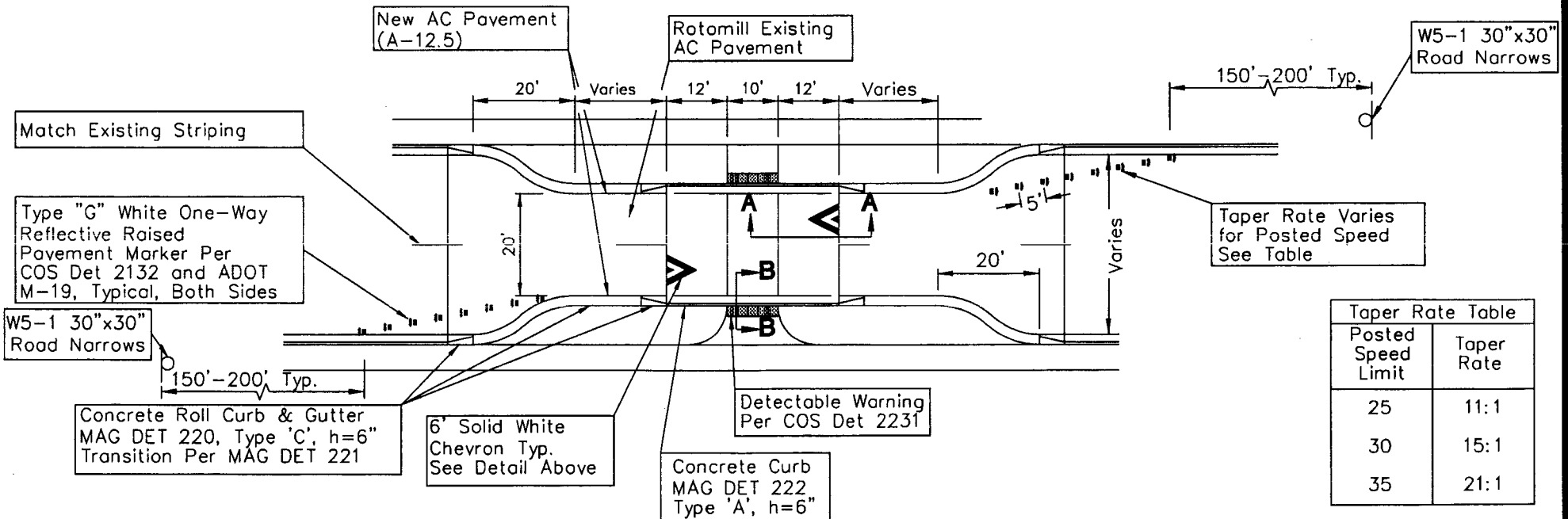

Posted Speed Limit	Taper Rate
25	11:1
30	15:1
35	21:1

DETAIL NO.
2293

City of Scottsdale
Standard Details

APPROVED BY:
Scottsdale Standards & Specifications Committee

MID-BLOCK PEDESTRIAN TABLE

DETAIL NO.
2293

REVISED 4/29/05

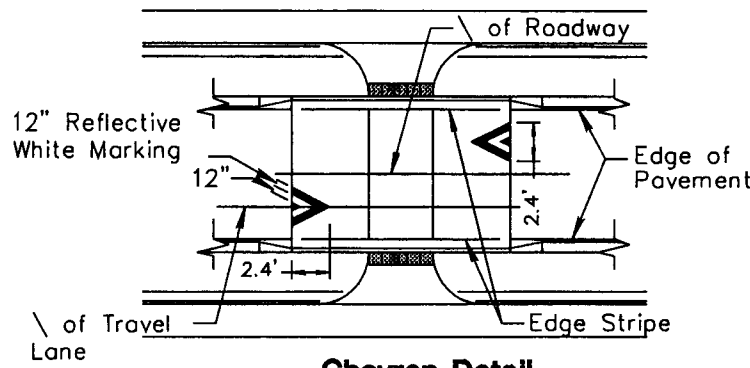

Chevron Detail

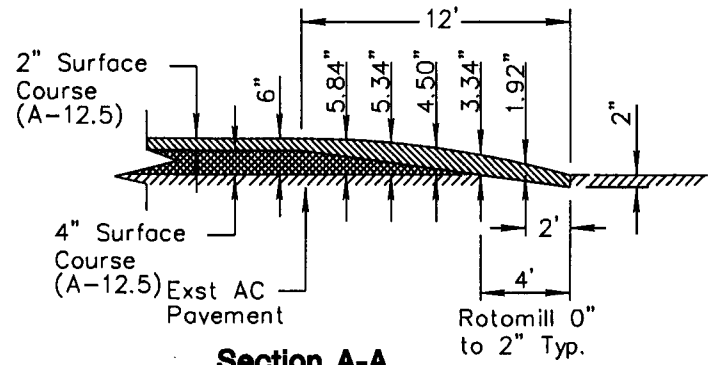

Section A-A

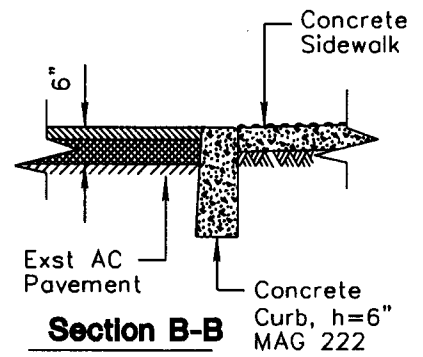

Section B-B

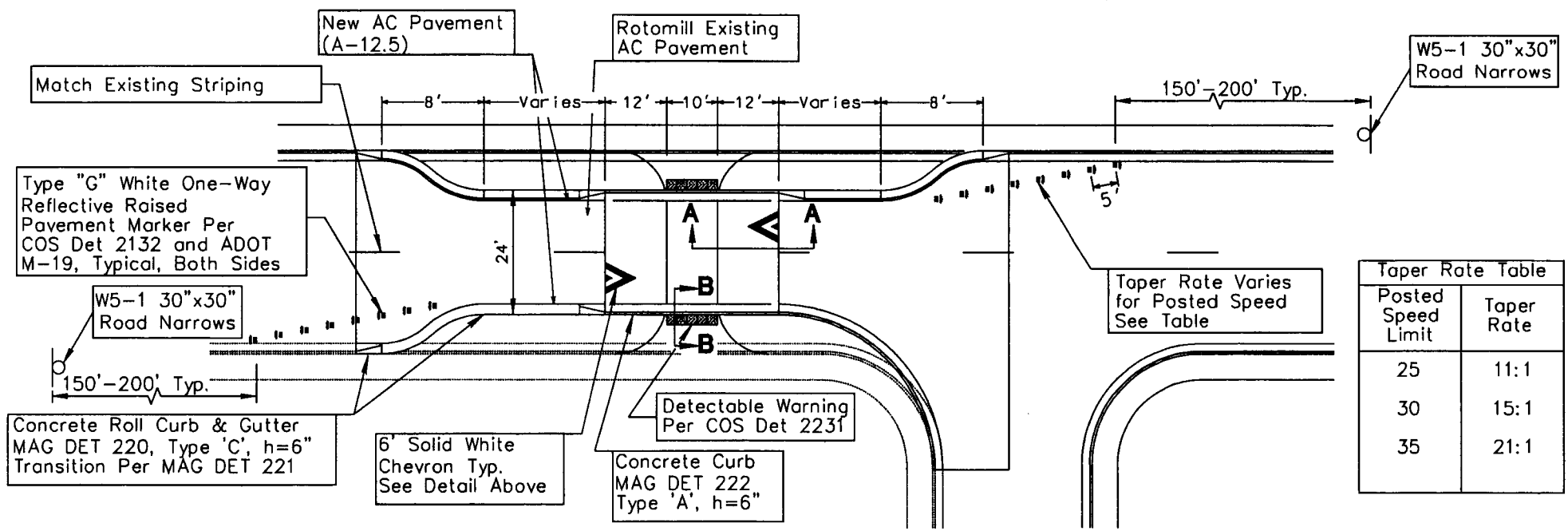

Posted Speed Limit	Taper Rate
25	11:1
30	15:1
35	21:1

REVISED 5/4/05

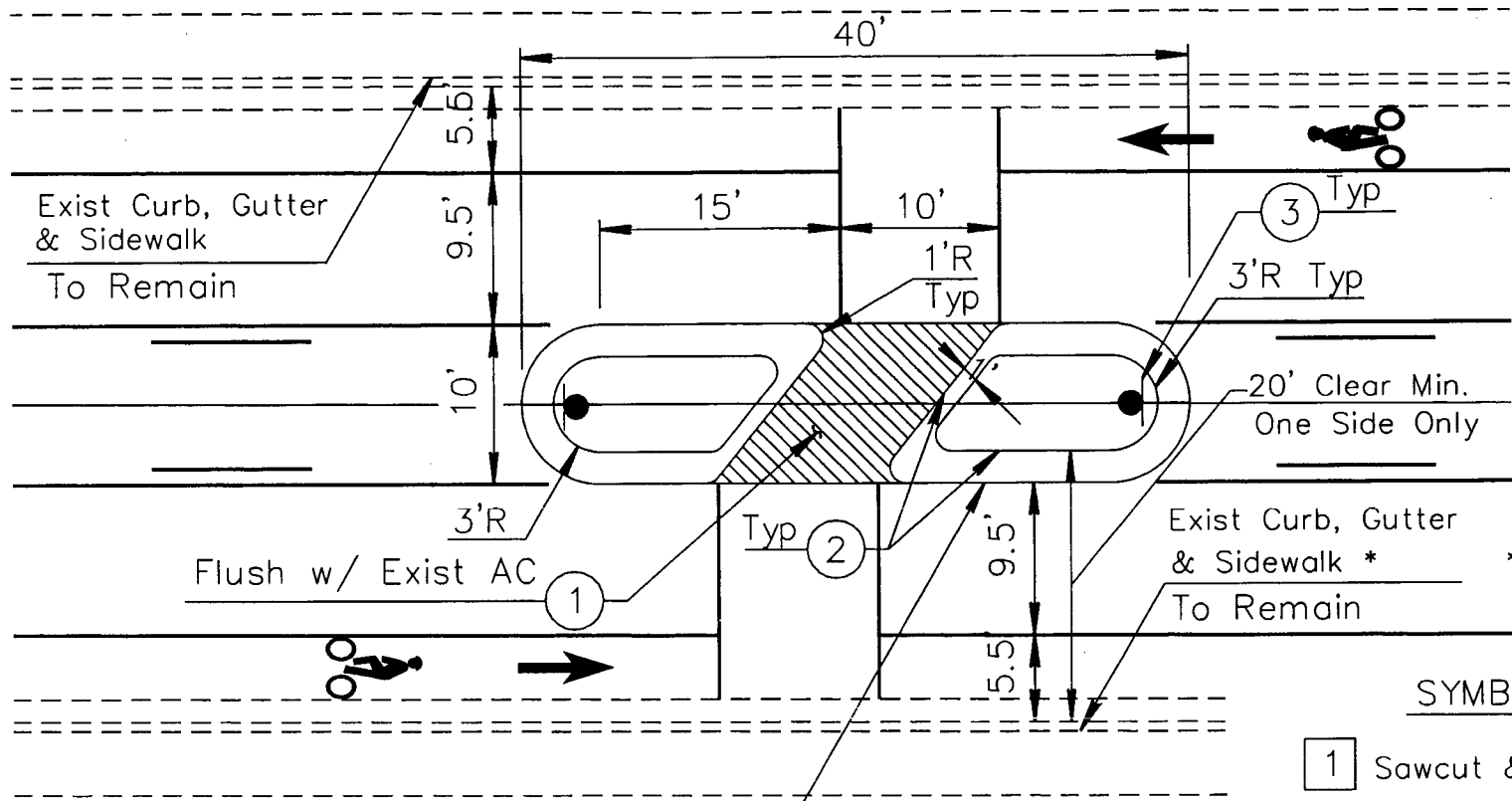

Sawcut at Lip of New Roll Curb (Typ)

SYMBOL LEGEND

- 1 Sawcut & Remove AC Pavement
- 1 8" Class "A" Concrete Pvmt per MAG Spec 324 & 725
- 2 Roll Curb per MAG Det 220 Type D
- 3 New Median Sign Panels & Post per COS Det 2133 Type A

* Or Replace With Rolled Curb To Obtain 20' Min

DETAIL NO. 2295

City of Scottsdale Standard Details

APPROVED BY: Scottsdale Standards & Specifications Committee

PEDESTRIAN REFUGE

DETAIL NO. 2295

REVISED 1/4/93

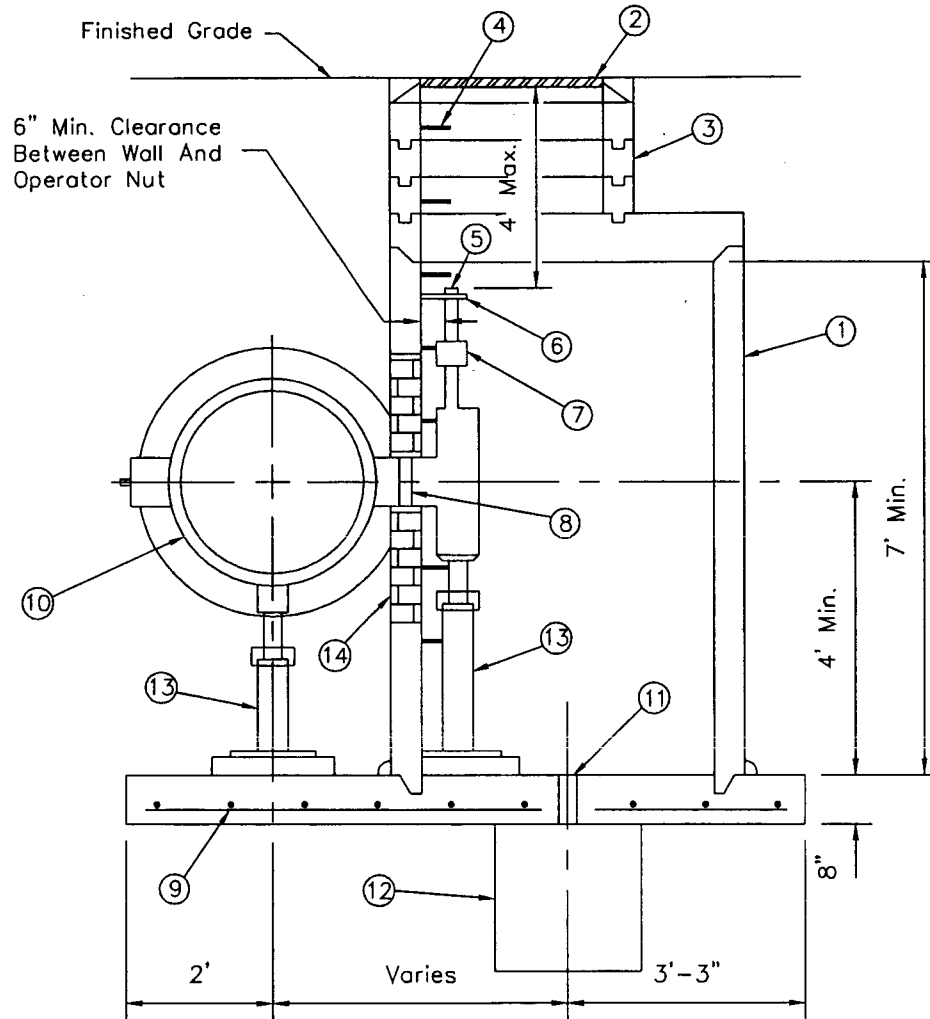

LEGEND

- ① 48" I.D. Manhole Shaft Per MAG Std. Detail 420, Type "B" Top
- ② 30" Manhole Frame & Cover Per MAG Std. Detail 424
- ③ Grouted Adjusting Rings
- ④ Polypropylene Manhole Steps Per MAG Std. Detail 428, 12" Spacing Typical
- ⑤ Operator Nut
- ⑥ Wall Bracket
- ⑦ Packing Gland
- ⑧ 6" Extension
- ⑨ #4 Rebar 12" On Center Each Way 2" Clear Typical
- ⑩ Butterfly Valve
- ⑪ 3" Diameter Drain
- ⑫ 8 Cu. Ft. Gravel Sump
- ⑬ Adjustable Pipe Saddle Support
- ⑭ Rectangular Cut-Out In Manhole Shaft, Fill Space Between Shaft And Pipe With 1" Sheet Foam, Brick And Mortar

SECTION

DETAIL NO. 2305-1	City of Scottsdale Standard Details	APPROVED BY: Scottsdale Standards & Specifications Committee	BUTTERFLY VALVE OPERATOR MANHOLE	DETAIL NO. 2305-1
-----------------------------	--	--	---	-----------------------------

REVISED 1/14/93

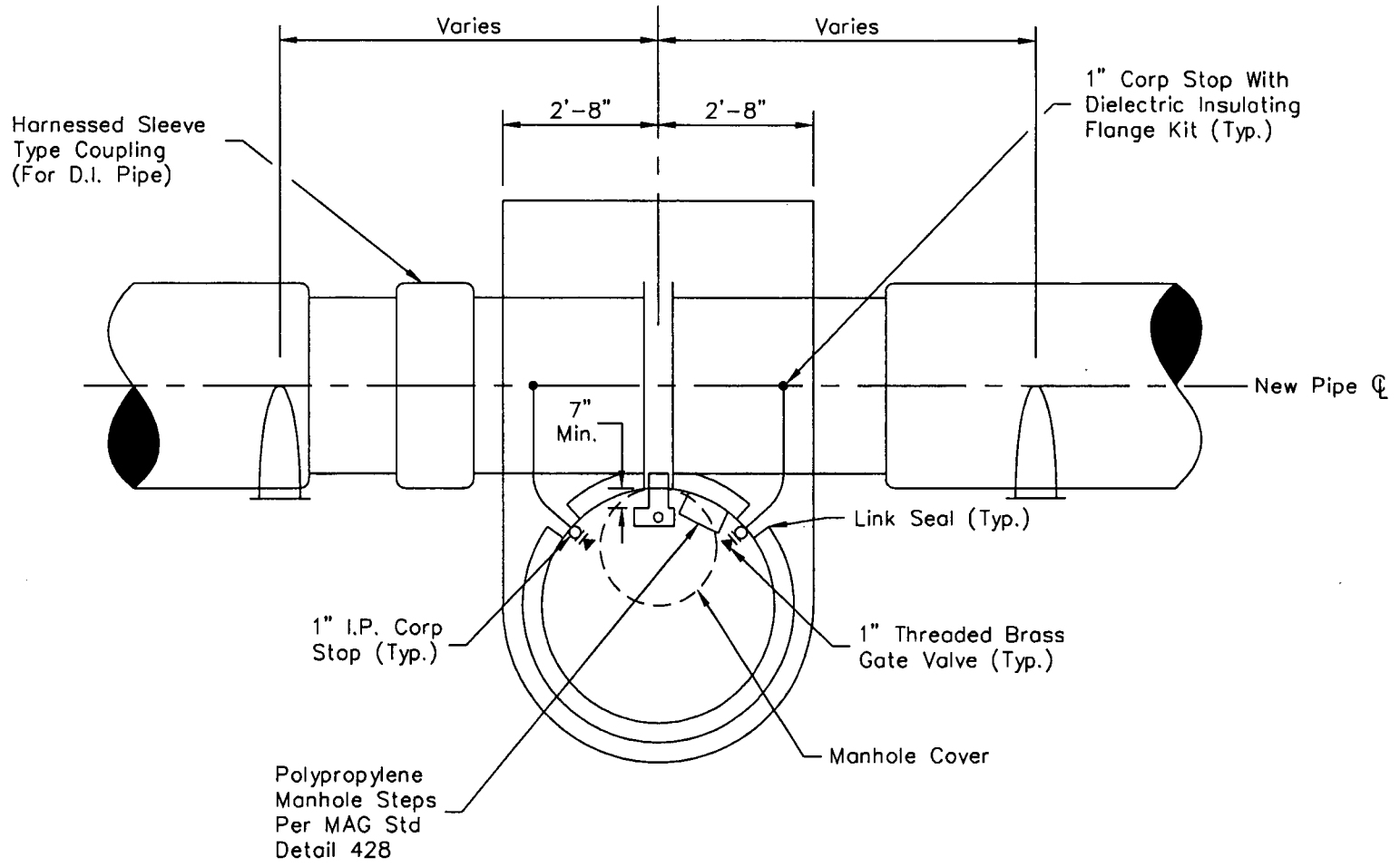

PLAN

DETAIL NO. 2305-2	City of Scottsdale Standard Details	APPROVED BY: Scottsdale Standards & Specifications Committee	BUTTERFLY VALVE OPERATOR MANHOLE	DETAIL NO. 2305-2
-----------------------------	--	--	---	-----------------------------

REVISED 2/22/99

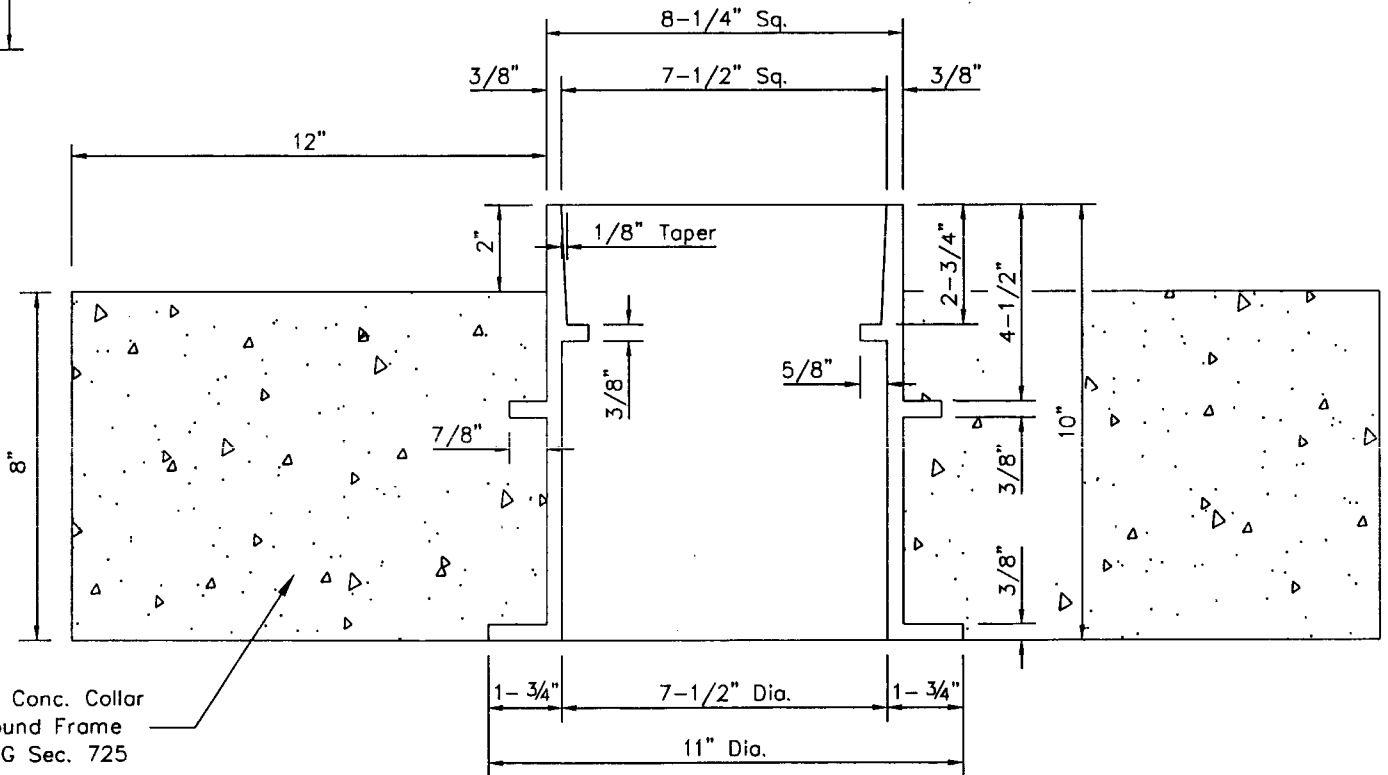
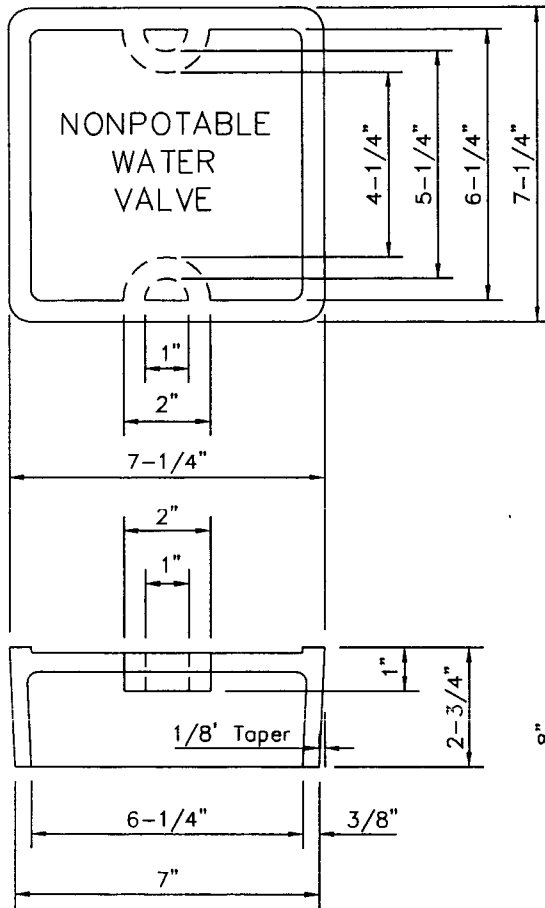

Class 'B' Conc. Collar
All Around Frame
Per MAG Sec. 725

NOTES

1. Round bottom for riser pipe, square top for cover.
2. All materials shall be cast iron per ASTM A48, Class 30B.
3. Nonpotable water valve box to be installed per M.A.G. Std. Detail 391.
4. The cast iron lid shall be marked "Nonpotable Water Valve" on the top side. Letters shall be 1" each and raised 1/8".

DETAIL NO.
2315

City of Scottsdale
Standard Details

APPROVED BY:
Scottsdale Standards &
Specifications Committee

NONPOTABLE WATER VALVE BOX & COVER

DETAIL NO.
2315



TOP VIEW

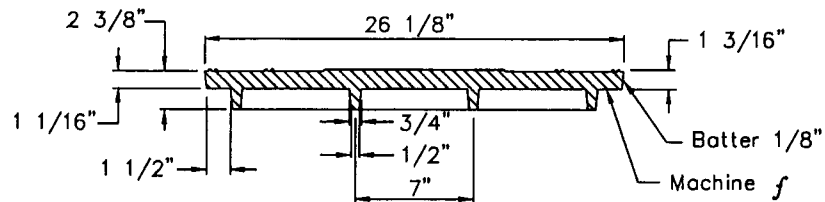

SECTION OF COVER

24" MANHOLE COVER

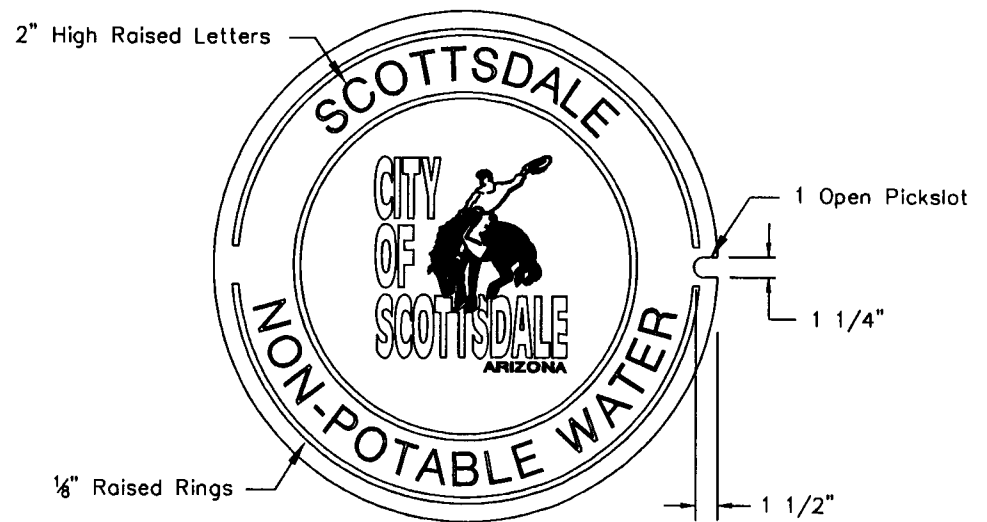

TOP VIEW

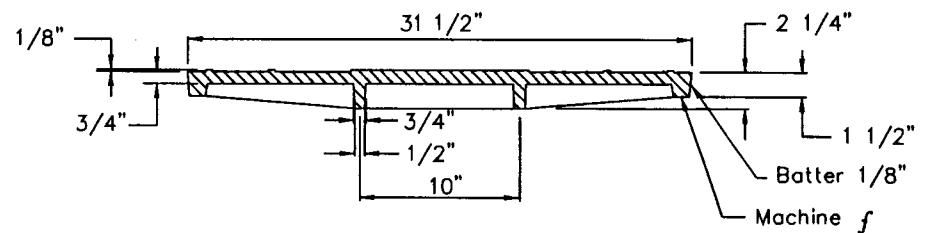

SECTION OF COVER

30" MANHOLE COVER

NOTES

1. Material: Cast Gray Iron ASTM A-48, Class 35B, Unpainted
2. The Total Width Of Individual Letters To Be Such That Letters And Words Are Equally Spaced And Balanced.
3. Letters To Be 2" In Height And Raised $\frac{1}{8}$ " Above Level Of Cover. Type Of Letters To Be Submitted For Approval.
4. Weight Of Castings Shall Be No More Than 2% Less Than Weight Specified. Castings Shall Conform To M.A.G. Section 787.

DETAIL NO.	City of Scottsdale	APPROVED BY:			DETAIL NO.
2320	Standard Details	Scottsdale Standards & Specifications Committee			2320
NON-POTABLE WATER MANHOLE COVER					

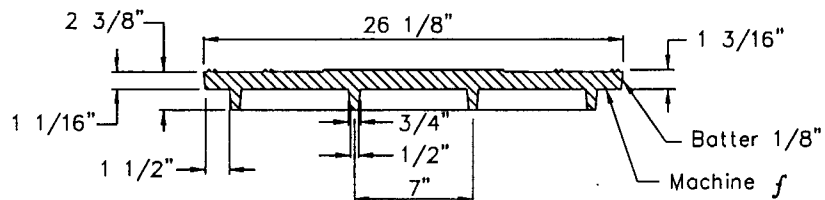
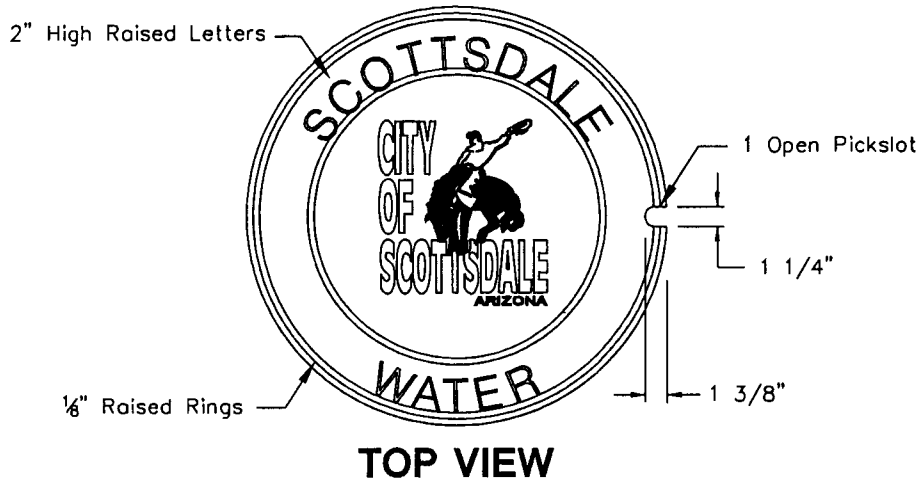

SECTION OF COVER
24" MANHOLE COVER

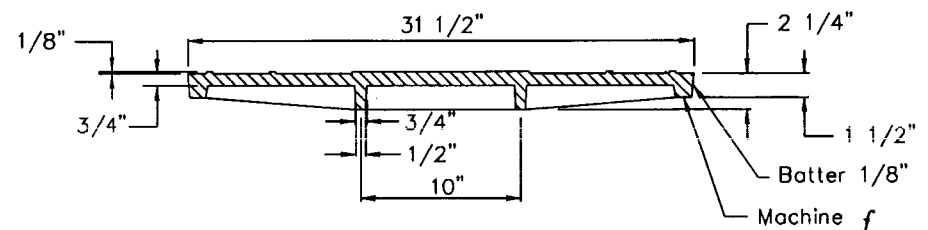
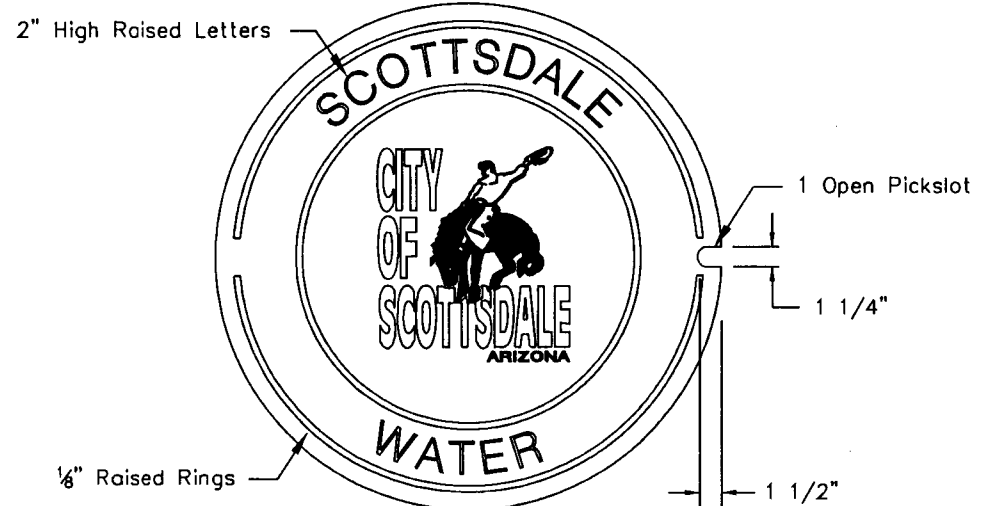

SECTION OF COVER
30" MANHOLE COVER

NOTES

1. Material: Cast Gray Iron ASTM A-48, Class 35B, Unpainted
2. The Total Width Of Individual Letters To Be Such That Letters And Words Are Equally Spaced And Balanced.
3. Letters To Be 2" In Height And Raised 1/8" Above Level Of Cover. Type Of Letters To Be Submitted For Approval.
4. Weight Of Castings Shall Be No More Than 2% Less Than Weight Specified. Castings Shall Conform To M.A.G. Section 787.

DETAIL NO.
2321

City of Scottsdale
Standard Details

APPROVED BY:
Scottsdale Standards & Specifications Committee

WATER MANHOLE COVER

DETAIL NO.
2321

REVISED 4/12/05

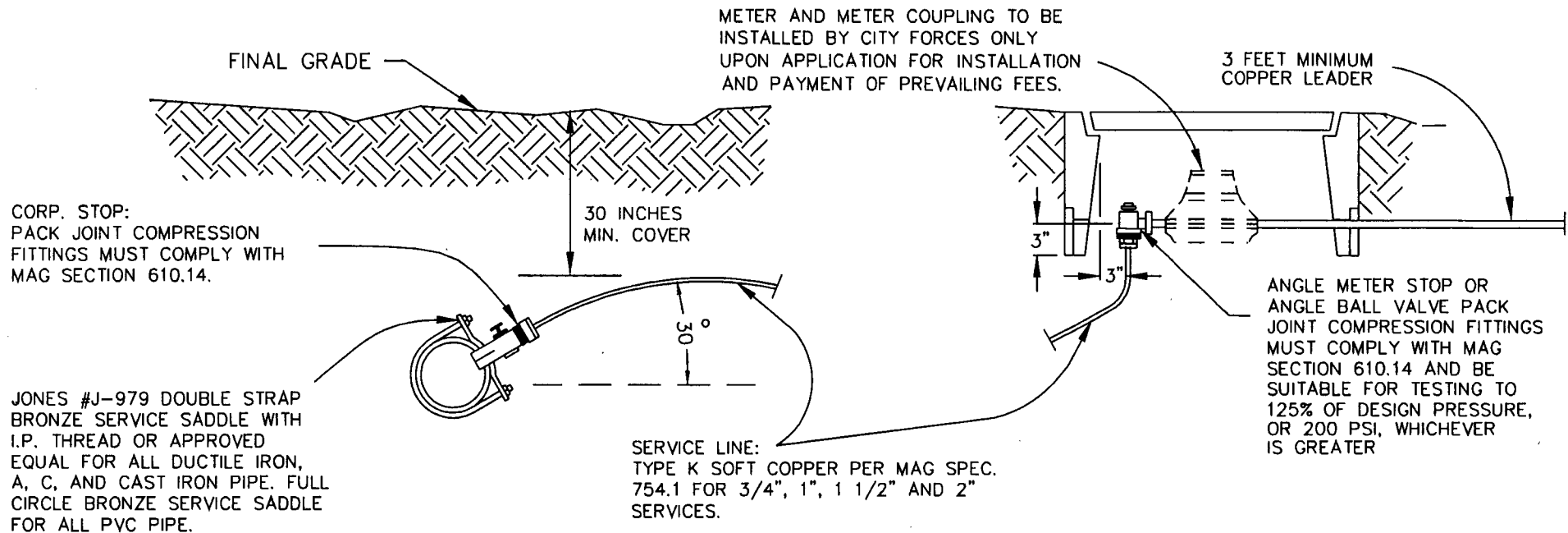

- NOTE:
1. All taps must be made using a service saddle.
 2. All service line sizes shall have the pack joint compression fittings for corp. stops and meter stops.
 3. Where a contractor is installing new water lines, he shall also install the water service connection. The installation shall include the service saddle, corp. stop, service pipe, appurtenant fittings, meter stop, concrete meter box and box cover, per M.A.G. Specifications.
 4. Copper service lines in the 3/4", 1", 1 1/2", and 2" sizes that cross streets will be one continuous piece. Only with the express written consent of Water & Wastewater Operations will joints be permitted under a road. When this occurs, pack joint fittings will be required; no soldered joints will be permitted.
 5. When all or part of a development is to be served by existing City of Scottsdale water mains, only authorized City of Scottsdale Water and Wastewater Operations personnel shall install the water service connection.
 6. Rough grade shall be set to 1 1/2 inches below top of meter box. Final landscape grade shall be set flush to top of meter box

DETAIL NO.
2330

City of Scottsdale
Standard Details

APPROVED BY:
Scottsdale Standards & Specifications Committee

WATER SERVICE LINE CONNECTION

DETAIL NO.
2330

REVISED 3/11/94

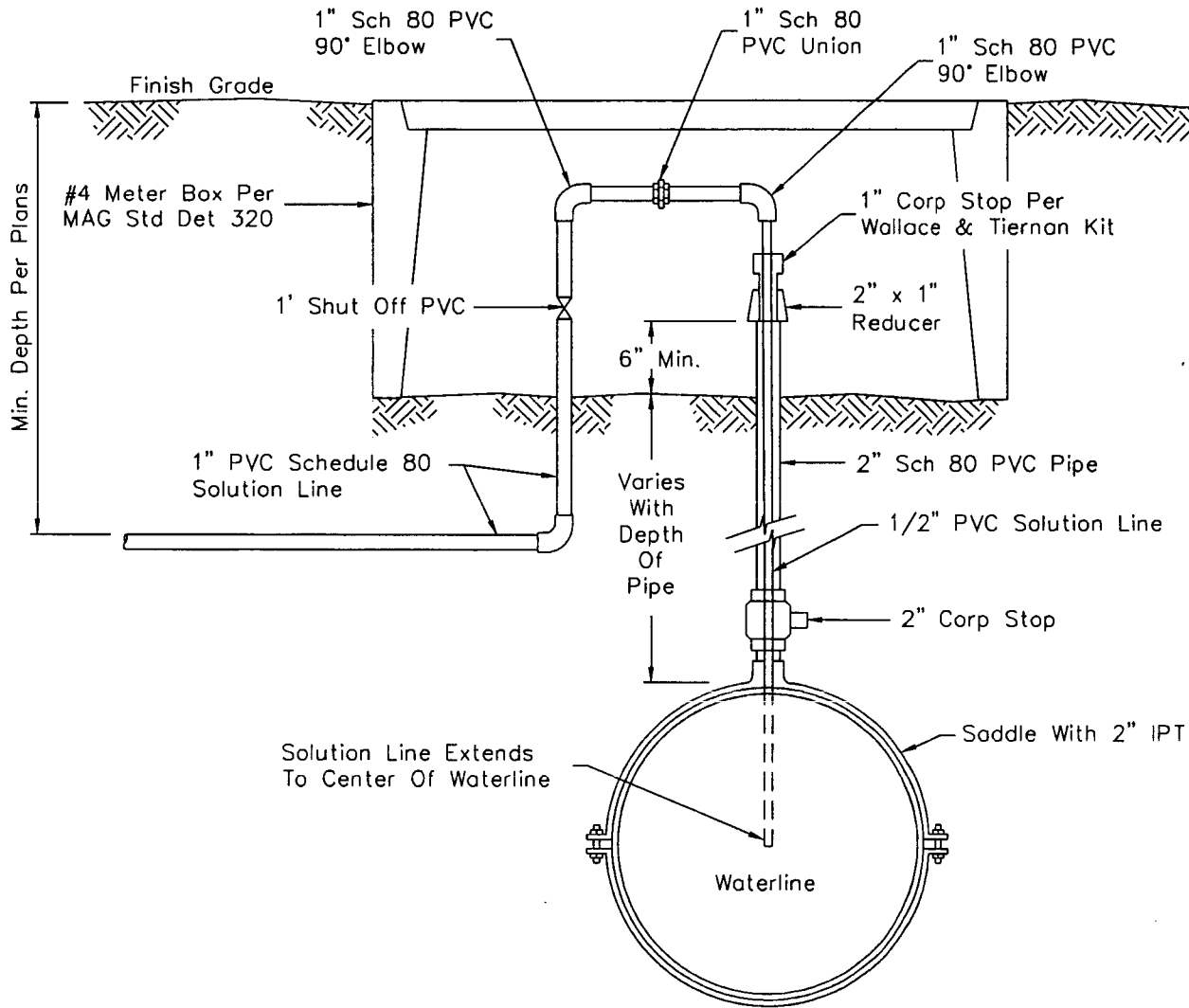

NOTE:
 Specifications on all fittings shall exceed the maximum pressures of the system.

DETAIL NO.
2332

**City of Scottsdale
 Standard Details**

APPROVED BY:
**Scottsdale Standards &
 Specifications Committee**

**CHLORINE INJECTION TAP
 FOR UNDERGROUND WATERLINES**

DETAIL NO.
2332

REVISED 1/4/93

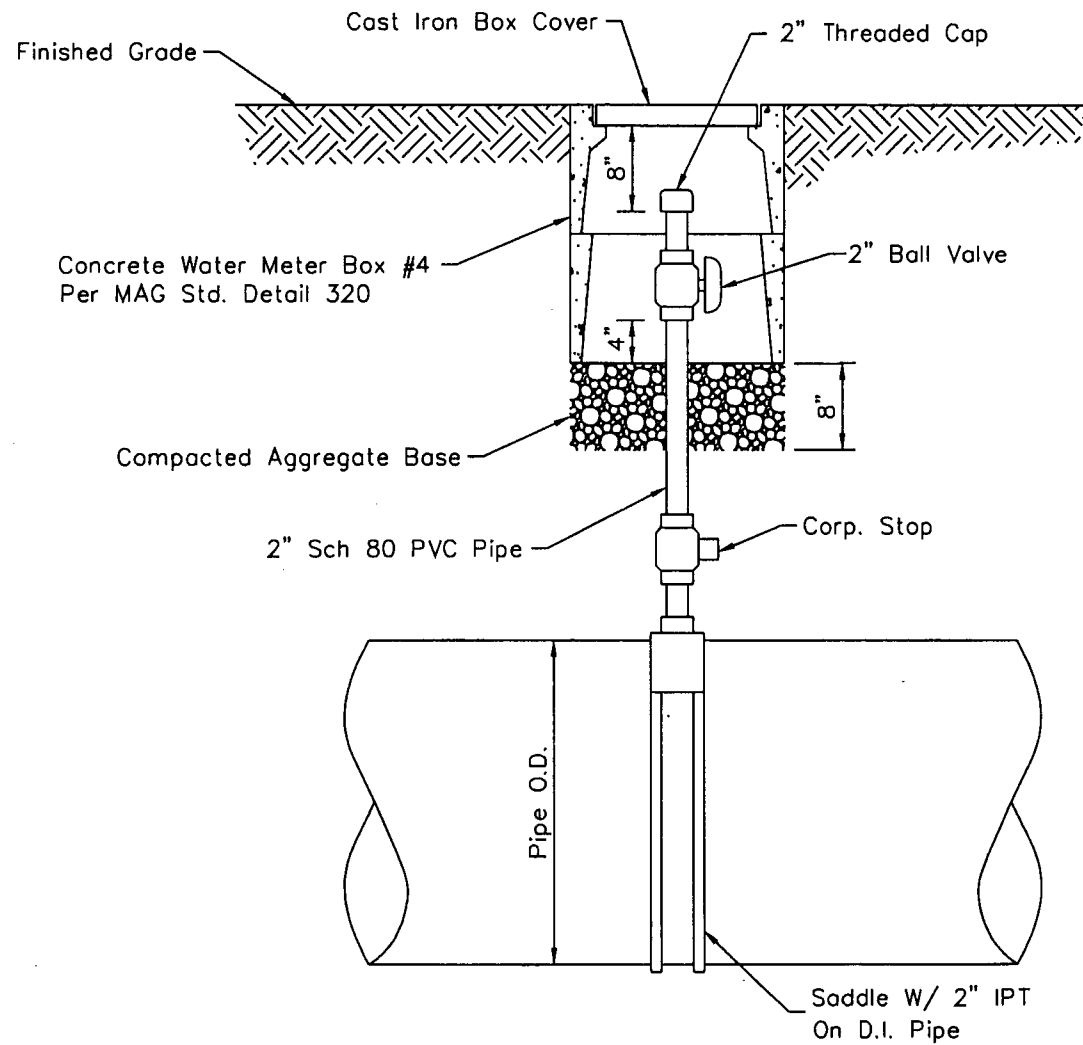

DETAIL NO.
2333

City of Scottsdale
Standard Details

APPROVED BY:
**Scottsdale Standards &
Specifications Committee**

TAP FOR FUTURE CHLORINE INJECTION

DETAIL NO.
2333

REVISED 2/27/01

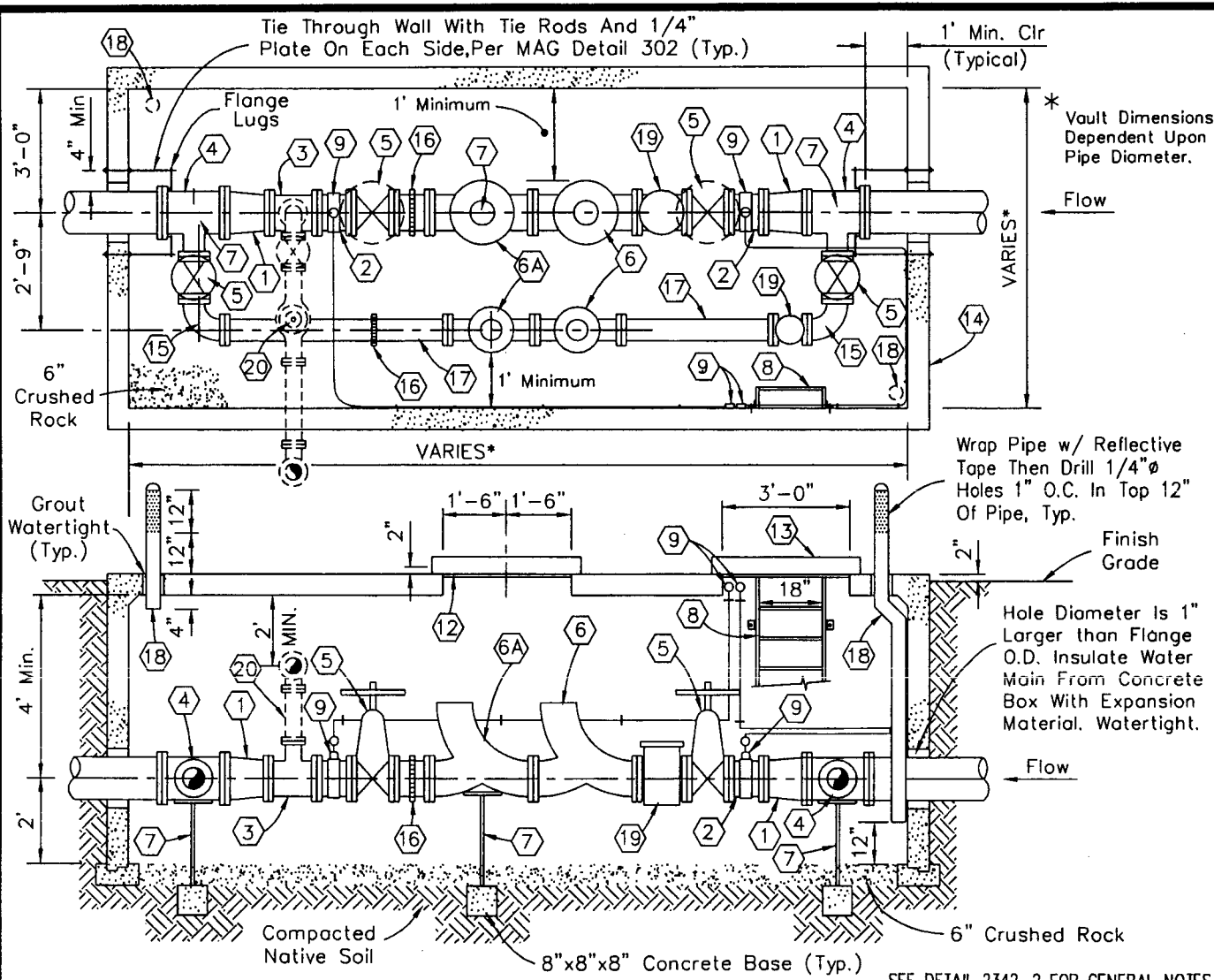

NOTES

- ① D.I.P. Flg Concentric Reducer
- ② D.I.P. Flg x Flg Spool Piece
- ③ D.I.P. Flg x Flg Tee. Install Only When Detail 2342-2 Is Used.
- ④ D.I.P. Flg Reducing Tee
- ⑤ Flg NRS Resilient Wedge Gate Valve, Inside Epoxy Coated, Low Zinc Stem w/ Wheel Handle
- ⑥ Flg PRV Bermad Model 723-20-V-I-U w/ Valve Position Indicator & Low Flow V-Port Plug And Must Have Stainless Steel Pilot Tubing, Or Approved Equal.
- ⑥A Flg PRV Bermad Model 723-20-V-I-U w/ Valve Or Approved Equal Will Be Installed When Pressure Differential Is 100 psi Or Greater.
- ⑦ 4" Galv Adjustable Pipe Supports w/ 1" Adj. Rod And Nut On 8"x 8"x 8" Concrete Base.
- ⑧ Galv Access Ladder Bolted To Wall, 6" Stand Off.
- ⑨ Saddle With 1" Corp., 3/8" Brass Reducer, 3/8" 3/8" Brass Tee w/ Oil Filled 0-200 Pressure Gauge. Install 3/8" Stainless Tubing Strapped To Wall As Shown w/ Oil Filled Gauges Mounted At Access Door. Gages To Be Readable From Outside Vault.
- ⑫ For 8" Valves Or Larger Install Utility Vault Raised/ Adjustable Access Door, Model 3636, Or Approved Equal, Centered Over Main Valves For Removal.
- ⑬ Utility Vault Raised/Adjustable Steel Access Door For Inspection, Model 3636 Or Approved Equal. Place In Corner With Ladder.
- ⑭ Precast Concrete Water Utility Vault, Per MAG Std Det 321 & 345-1, Inside Dimensions Vary Depending On Pipe Size.
- ⑮ D.I.P. Flg 90° Elbow
- ⑯ Victaulic Coupling Or Approved Equal w/ All Thread Tie Rods.
- ⑰ D.I.P. Flg Pipe Spool
- ⑱ 4" Galv. Steel Vent Pipe With Cap. Strap Pipe To Wall. Install Vents In Unpaved Areas Only.
- ⑳ Basket Type Strainer
- ⑳ 4" Pressure Relief Bermad Model 730-I-U w/ Valve Position Indicator Or Approved Equal Required When Pressure Differential Meets Or Exceeds 100 PSI. See Detail 2342-2.

* Engineer to note direction of flow and pressure setting on the plans.

DETAIL NO.
2342-1

**City of Scottsdale
Standard Details**

APPROVED BY:
**Scottsdale Standards &
Specifications Committee**

SEE DETAIL 2342-2 FOR GENERAL NOTES

PRESSURE REDUCING VALVE

DETAIL NO.
2342-1

REVISED 2/27/01

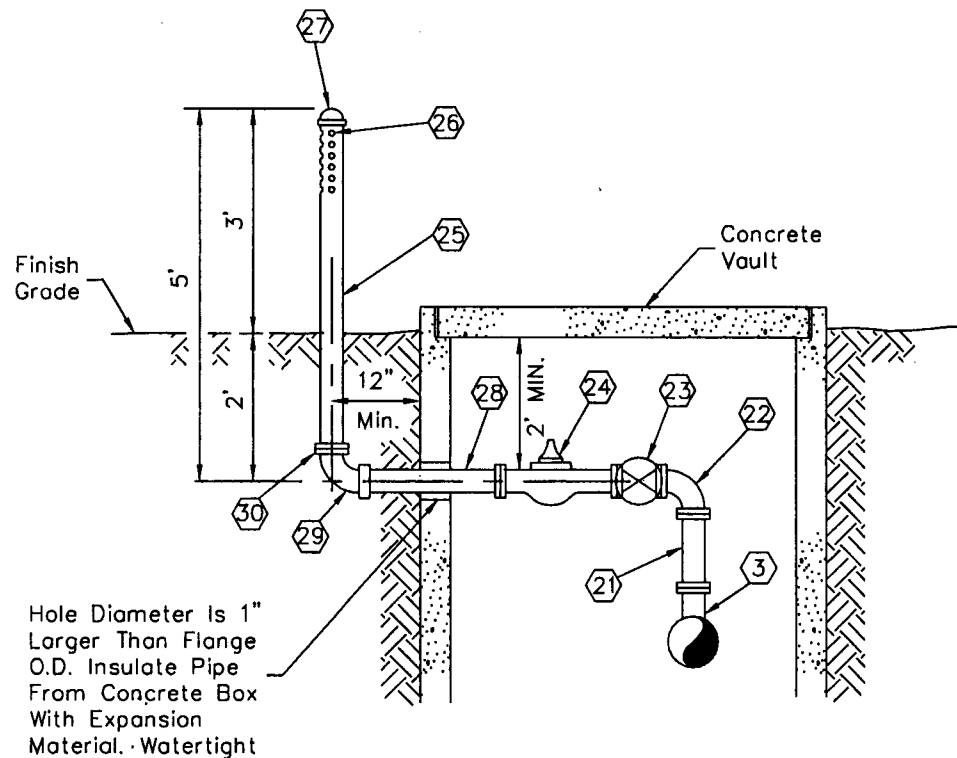

PRESSURE RELIEF OUTLET ASSEMBLY DETAIL

SEE NOTE 20 DETAIL 2342-1

NOTES

- 3 Flg x Flg Tee, See Detail 2342-1
- 21 4" Flg Connecting Piece
- 22 4" DIP Flg x Flg 90° Elbow, w/ Restrained Joints (Meg A Lug Or Approved Equal)
- 23 4" Flg NRS Resilient Wedge Gate Valve, Inside Epoxy Coated, Low Zinc Stem w/ Handwheel
- 24 4" Flg PRV Bermad Model 730-I-U Or Approved Equal, Epoxy Coated w/ Valve Position Indicator
- 25 4" SCH. 40 Steel Pipe (Painted Desert Beige)
- 26 6 Rows 2" O.C. Of 3-1"Ø Holes, 180° Spray Pattern
- 27 4" SCH 40 Steel Cap (Threaded)
- 28 4" Ductile Pipe Spool
- 29 4" DIP MJ x Flg 90° Elbow
- 30 Flanged Connection w/ Breakaway Bolts

GENERAL NOTES

1. All pipe and valves are to be rated per system pressure.
2. Pilot lines for all controls will be stainless steel tubing.
3. Stainless tubing bends will be uniform and made with a tubing bender.
4. Bypass line (small PRV) shall be 4" Min. D.I.P.
5. Airvents and relief outlet riser pipe shall not be located within 12 feet of an existing edge of pavement or within 2 feet of a barrier type curb or 2' back of sidewalk.

DETAIL NO.
2342-2

**City of Scottsdale
Standard Details**

APPROVED BY:
**Scottsdale Standards &
Specifications Committee**

PRESSURE REDUCING VALVE

DETAIL NO.
2342-2

REVISED 2/27/01

3" Dia. Sch 40 Steel Vent Pipe W/ Cap And Bracket as Manufactured By Blue Dot Steel Or Approved Equal. Wrap Pipe With Reflective Tape Then Drill 1/4" ϕ Holes 1" O.C. In Top 12" Of Pipe. Strap Pipe To Wall. Install Vents In Unpaved Areas Only.

NOTE: Meter Vaults To Be Pre-Cast Concrete Unless Otherwise Approved By Water Operations. See MAG Std Detail 321 For Vault Construction.

VAULT DIMENSION TABLE			
MAIN SIZE	3"	4"	6"
(A)	8'-4"	10'-6"	12'-0"
(B)	4'-6"	5'-0"	5'-0"

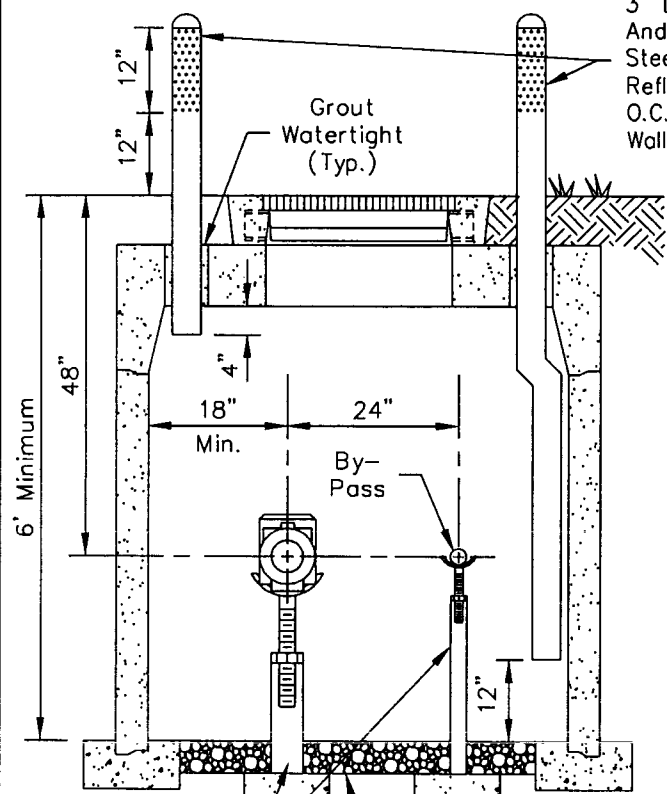

Adjustable Metal Pipe Support At Each Valve, And, Two Spaced Equally On Bypass Assembly

12"x12"x6" Concrete Base (Typ.)

4" Crushed Rock

Insulate Water Main From Concrete Box With 1" Ramneck Or Other Expansion Material Approved By The Engineer. Grout Balance Of Opening Per MAG Specifications.

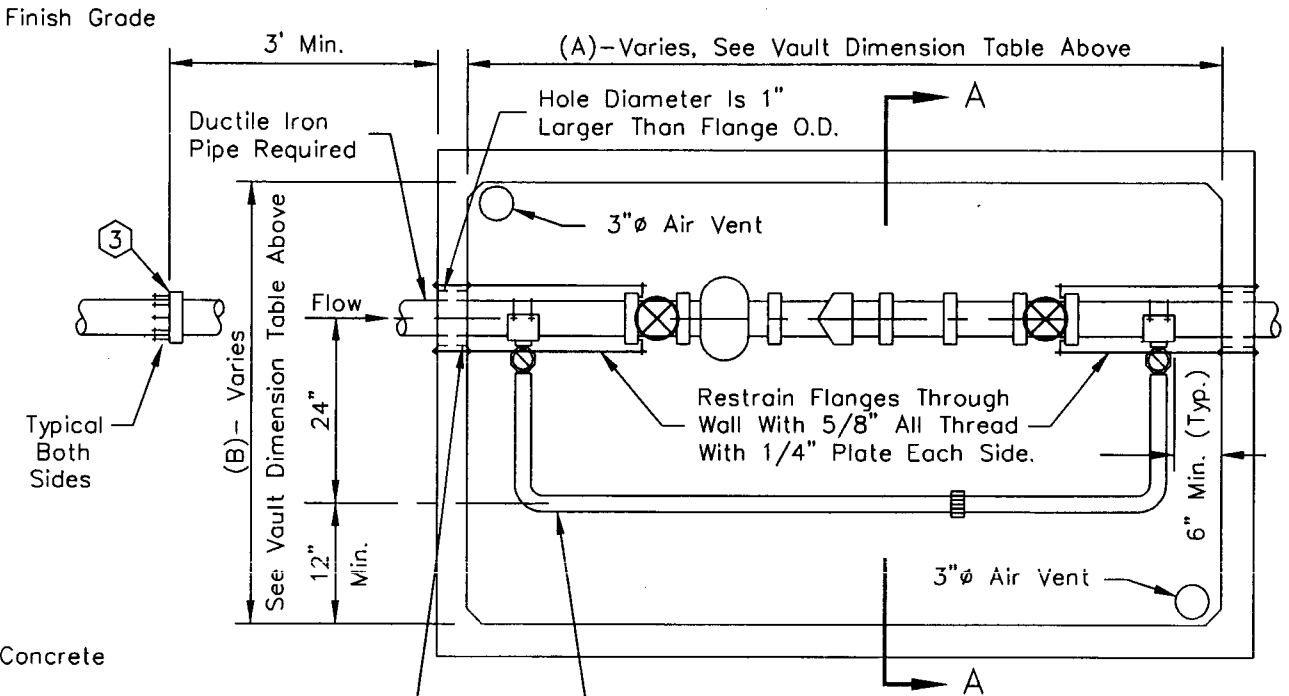

Except For 2" Copper Bypass All Fittings Will Be Flanged. Uniflange Not Acceptable Unless Approved By Water Operations. 2" Copper Bypass Will Be Joined With Silver Solder Except At 2" Corp Stop Which Will Be Pac Joint.

VAULT INSTALLATION

PLAN

SHEET 1 OF 2

DETAIL NO. 2345-1

City of Scottsdale Standard Details

APPROVED BY: Scottsdale Standards & Specifications Committee

3", 4", 6" WATER METER

DETAIL NO. 2345-1

REVISED 2/27/01

For Vault Construction
See MAG Std Det 321

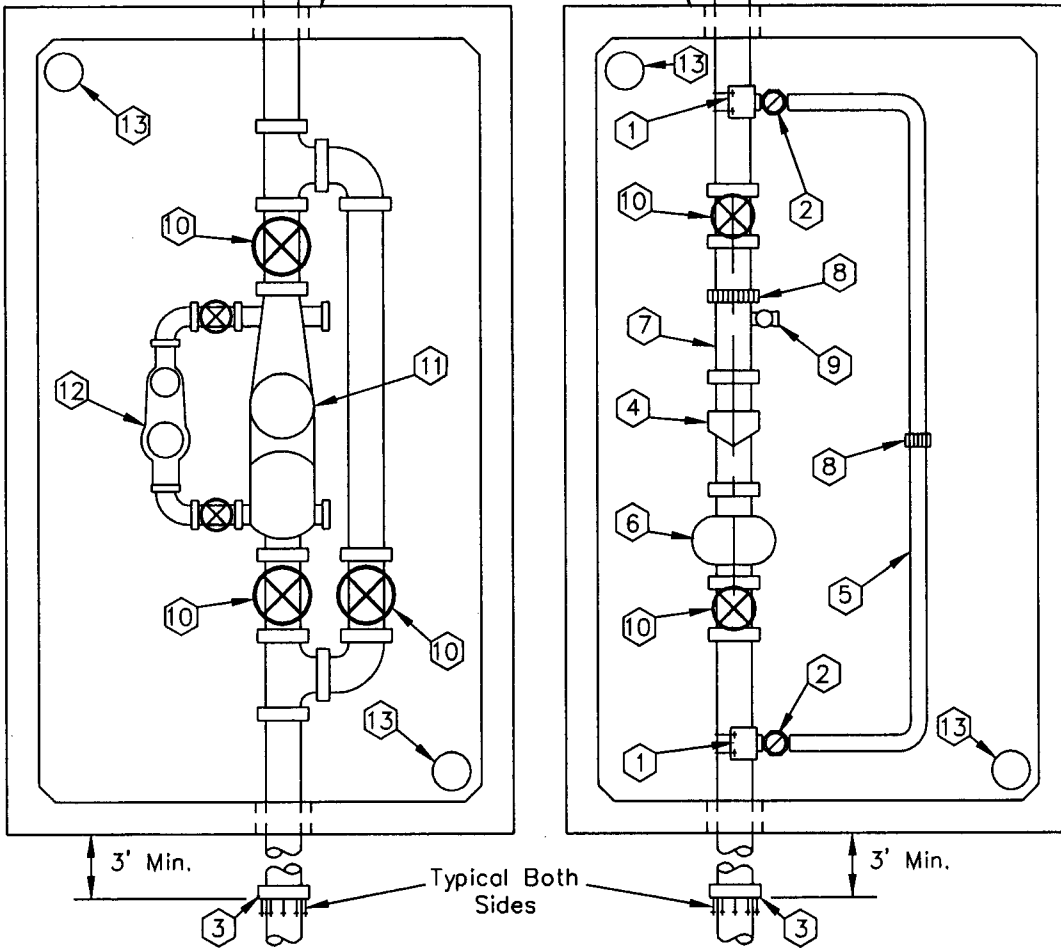

KEY NOTES

- ① Double Strap All Bronze Service Saddle, Or Flanged x Flanged Tee With Flanged X Flanged Valve For Sizes 3" Or Larger.
- ② Corp. Stop, 2"(Ball Type), Or R.W. Gate Valve With Non-Rising Stem Handwheel Operator For 3" Or Larger.
- ③ Adaptor, Flanged To Mech. Joint For A.C.P.
- ④ Turbine (High Flow) Or Compound Meter, See Note 4 Below.
- ⑤ 2" Ridged Type "K" Copper By-Pass Line, 3" Or Larger To Be Ductile Iron. Not Less Than One Pipe Size Smaller Than Meter In Note 4.
- ⑥ Strainer, Supplied with Meter.
- ⑦ Flanged Spool, (3 Pipe Diameters In Length, Min.).
- ⑧ Provide Victaulic Coupling Or Approved Equal For All Lines 3" Or Larger.
- ⑨ 2" Threaded Outlet And Ball Valve. Not Needed If Vertical Test Valve Is Provided On Meter.
- ⑩ Resilient Wedge Gate Valve, Flanged, With Hand Wheel, Open Left, With Non-Rising Stem.
- ⑪ Turbine (High Flow) Or Compound Meter, See Note 4 Below.
- ⑫ 2" Turbine Meter: Sensus "W-160" Or Hersey "MHR" Or Neptune Trident Turbine.
- ⑬ 3"∅ Air Vent, See Sheet 1 Of 2.

NOTES

- 1. For Larger Meters Special Vault Design Is Required.
- 2. Use Of Remote Reading Device At Option Of Utility.
- 3. An Approved Backflow Prevention Assembly Shall Be Required Downstream Of The Water Meter. Contact Water Resources, Backflow Prevention For Specific Information.
- 4. Meter To Be Provided By City Upon Payment Of Fees.

SHEET 2 OF 2

DETAIL NO. **2345-2**
City of Scottsdale
Standard Details

APPROVED BY:
Scottsdale Standards & Specifications Committee

3, 4", 6" WATER METER

DETAIL NO.
2345-2

REVISED 3/08/05

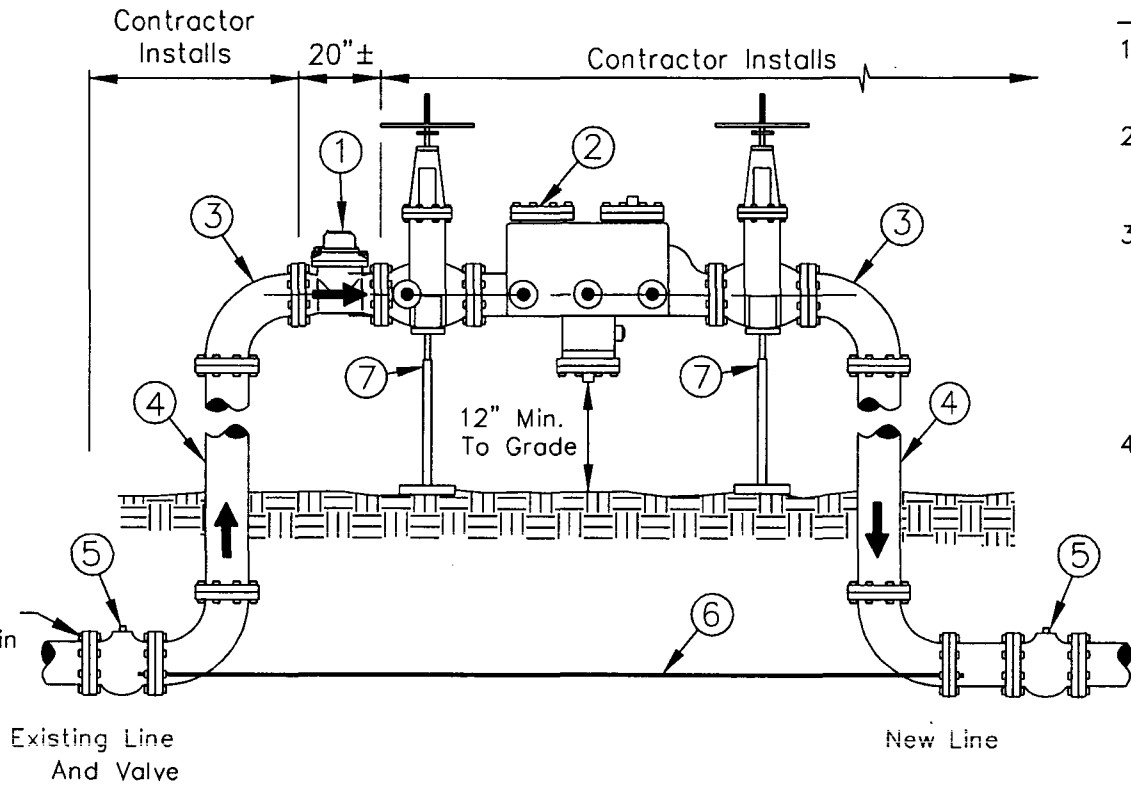

GENERAL NOTES

1. Contractor to supply and install above ground piping and fittings to accommodate 3" meter, backflow preventer and 2 - 90° ells.
2. Contractor to remove piping and fittings after acceptance of new water main and complete connection as per MAG Standards.
3. Approvals for backflow assemblies must have Seal Approval from the American Society of Sanitation Engineers. Backflow assemblies installed on fire suppression systems must also have approval from Underwriters Laboratories and/or Factory Mutual Research Corporation.
4. Backflow backflow assemblies must be tested by a certified tester that is recognized by the City of Scottsdale.

Adapt Size And Material To New Non-Approved Water Main

LIST OF MATERIALS

- | | |
|--|---|
| <ul style="list-style-type: none"> ① 3" Turbine Construction Meter With 3" Flanges, Supplied By City. ② 3" Approved Reduced Pressure Principle Backflow Prevention Assembly, Supplied By Contractor. ③ 3" Flanged Ductile Iron 90° Ell, Supplied By Contractor. ④ 3" Ductile Iron Spool. | <ul style="list-style-type: none"> ⑤ Line valves shall be within a 20' maximum distance upstream and downstream of flow meter or as approved by COS, and shall remain in-place after removal of temporary meter. ⑥ 3/4"Ø zinc coated threaded rod. ⑦ Adjustable Metal Pipe Support (Required). |
|--|---|

DETAIL NO. 2346	City of Scottsdale Standard Details	APPROVED BY: Scottsdale Standards & Specifications Committee	TEMPORARY CONSTRUCTION METER	DETAIL NO. 2346
---------------------------	---	--	-------------------------------------	---------------------------

REVISED 4/12/05

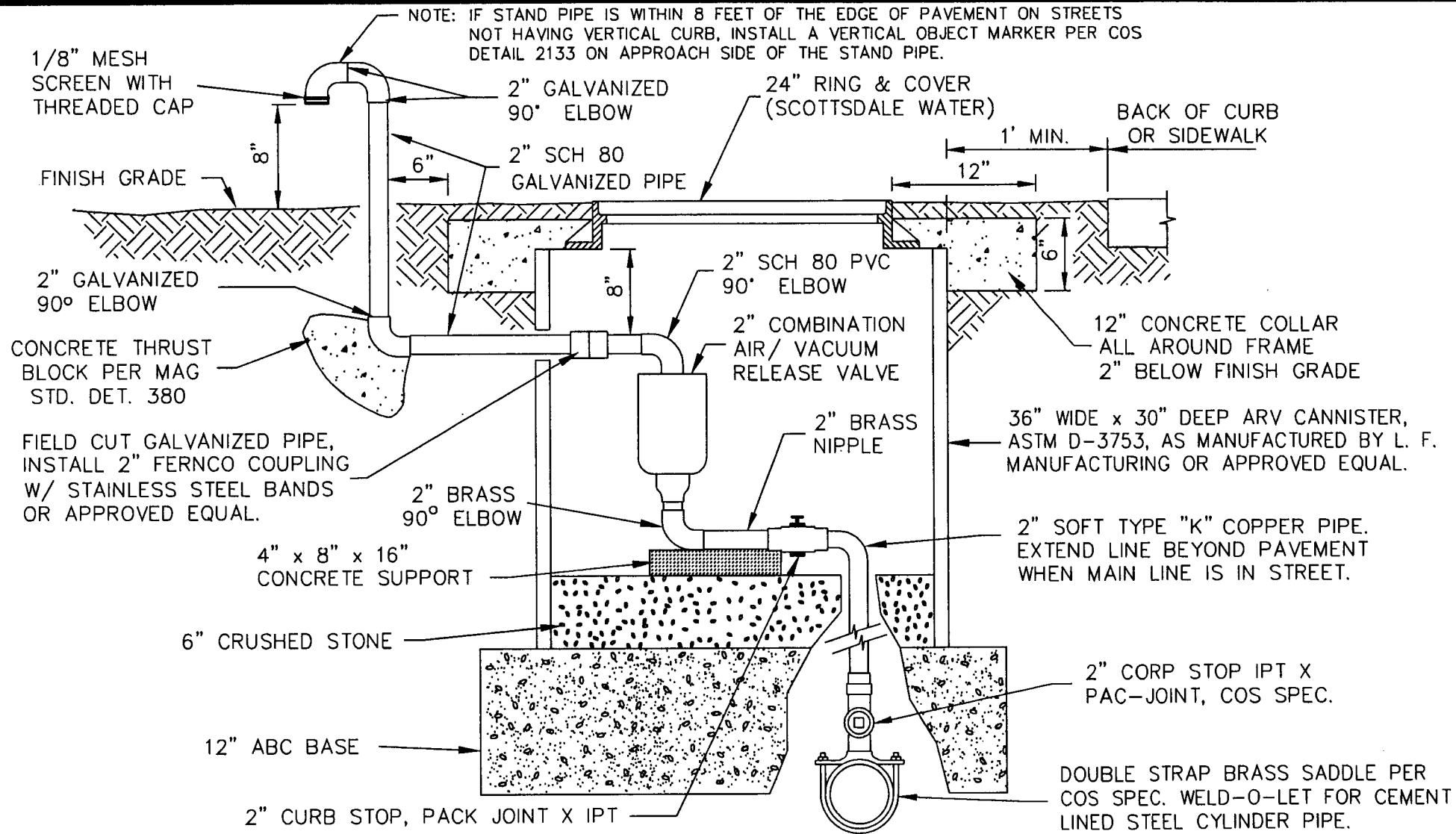

DETAIL NO.
2348

City of Scottsdale
Standard Details

APPROVED BY:
Scottsdale Standards & Specifications Committee

2" AIR/VACUUM RELEASE VALVE

DETAIL NO.
2348

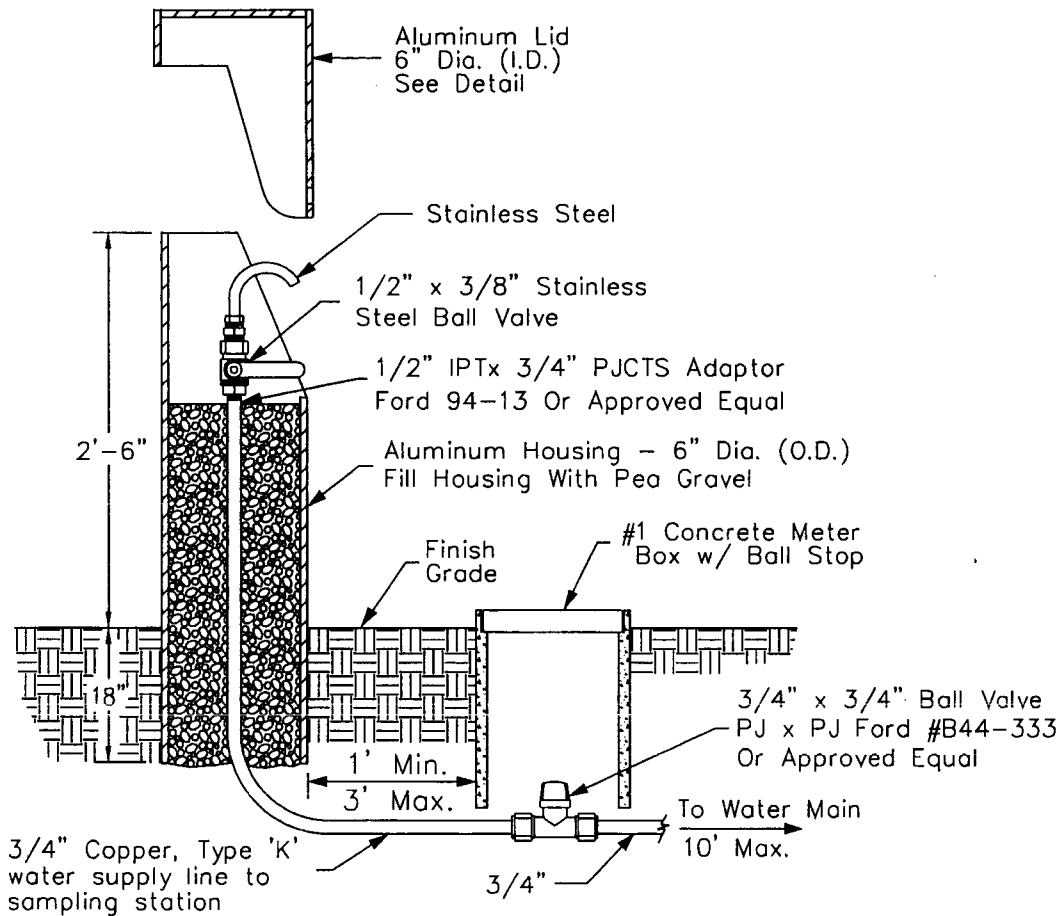

TYPICAL INSTALLATION

N.T.S.

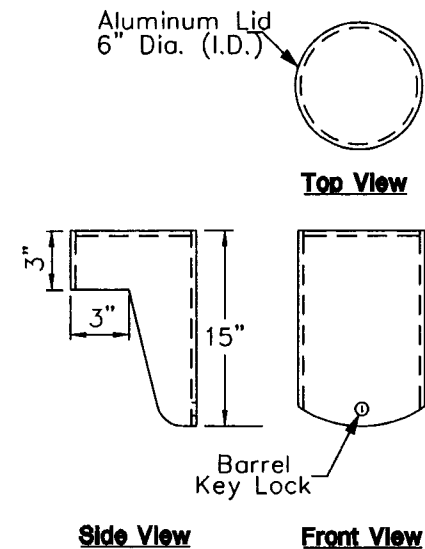

LID DETAILS

N.T.S.

NOTES:

1. Water Quality Sampling Station to be Korlean or approved equal.
2. Keys to locks shall be delivered to City of Scottsdale Water Quality Department upon acceptance.

DETAIL NO.
2349

**City of Scottsdale
Standard Details**

APPROVED BY:
**Scottsdale Standards &
Specifications Committee**

WATER QUALITY SAMPLING STATION

DETAIL NO.
2349

REVISED 5/5/04

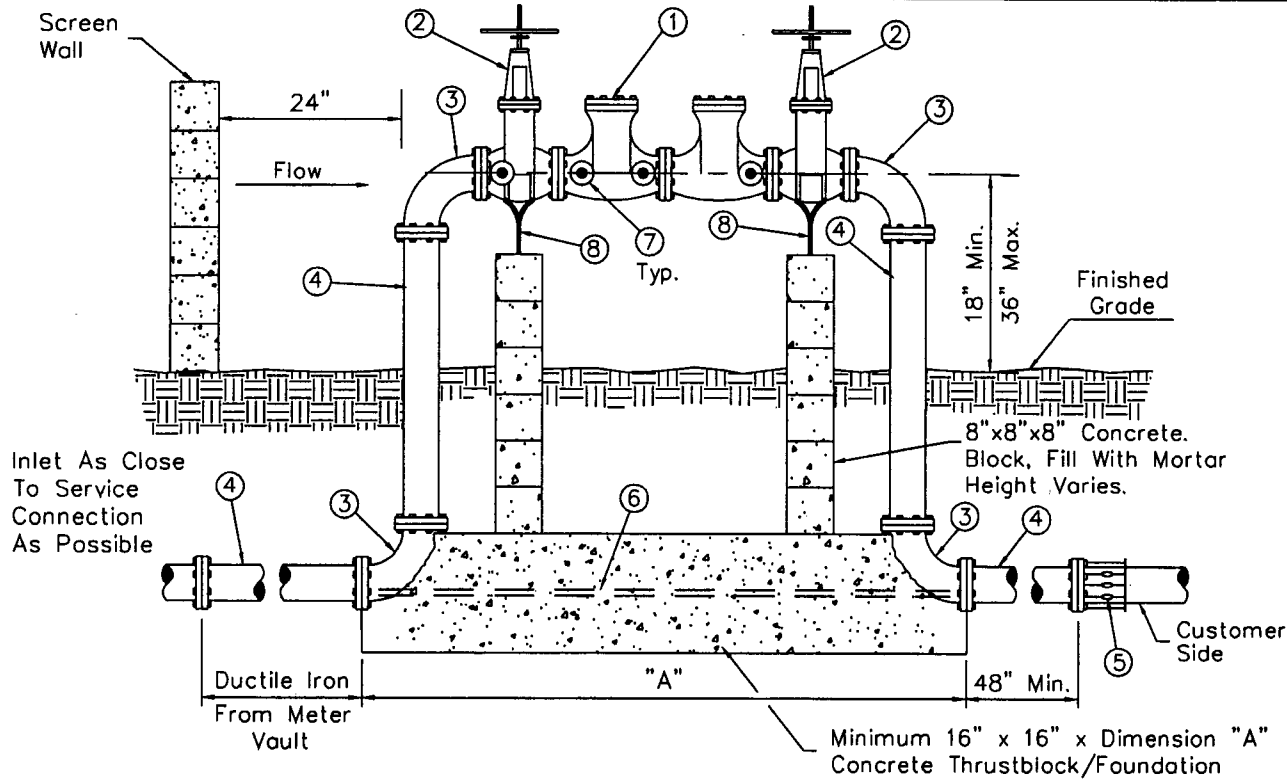

GENERAL NOTES

1. Backflow assemblies must be tested by a certified tester that is recognized by the City of Scottsdale.
2. Backflow preventers shall be painted light tan or a color to match the building. Do not paint the name plate or any brass parts on the assembly.
3. For backflow preventers requiring guard posts see Detail 2356. Backflow preventers enclosed by screening shall maintain a 24 inch clearance around the assembly.
4. Finished grade underneath the backflow preventer shall be at 95% compaction.
5. Backflow preventers on fire lines may require tamper switches on the shut off valves. Contact City Of Scottsdale Plan Review, Fire Dept.
6. Call for underground inspection before backfilling trench.
7. Vertical installations of assemblies on fire sprinkler systems are allowed using assemblies approved for use in the vertical position on fire systems.
8. Approvals for backflow assemblies must have Seal Approval from the American Society of Sanitation Engineers. Backflow assemblies installed on fire suppression systems must also have approval from Underwriters Laboratories and/or Factory Mutual Research Corporation.

LIST OF MATERIALS

- | | |
|---|---|
| <ul style="list-style-type: none"> ① Approved double check valve backflow prevention assembly. ② Resilient seated gate valve.
O.S. & Y. (fire line connection)
N.R.S. (non fire line) ③ 90° ell. Flanged D.I.P. 3" thru 10", Mega Lug or approved equal may be used on underground joints. ④ Pipe spool. Flanged D.I.P. 3" thru 10", Mega Lug or approved equal may be used on underground joints. ⑤ Flanged adapter (when required) | <ul style="list-style-type: none"> ⑥ 3/4" zinc coated threaded rod, (5/8" rod on 3" to 4" sizes), bolt to flanges as shown, typical both sides. ⑦ Test cocks with brass plugs or adaptors with caps installed. (4 required) ⑧ Adjustable metal pipe supports and concrete block supports with 1" adjusting rod and nut on assemblies 4" and larger. Install above grade. |
|---|---|

DETAIL NO.

2351

**City of Scottsdale
Standard Details**

APPROVED BY:

**Scottsdale Standards &
Specifications Committee**

**DOUBLE CHECK VALVE BACKFLOW PREVENTION ASSEMBLY
FOR ASSEMBLIES 3 INCHES THRU 10 INCHES**

DETAIL NO.

2351

REVISED 5/05/04

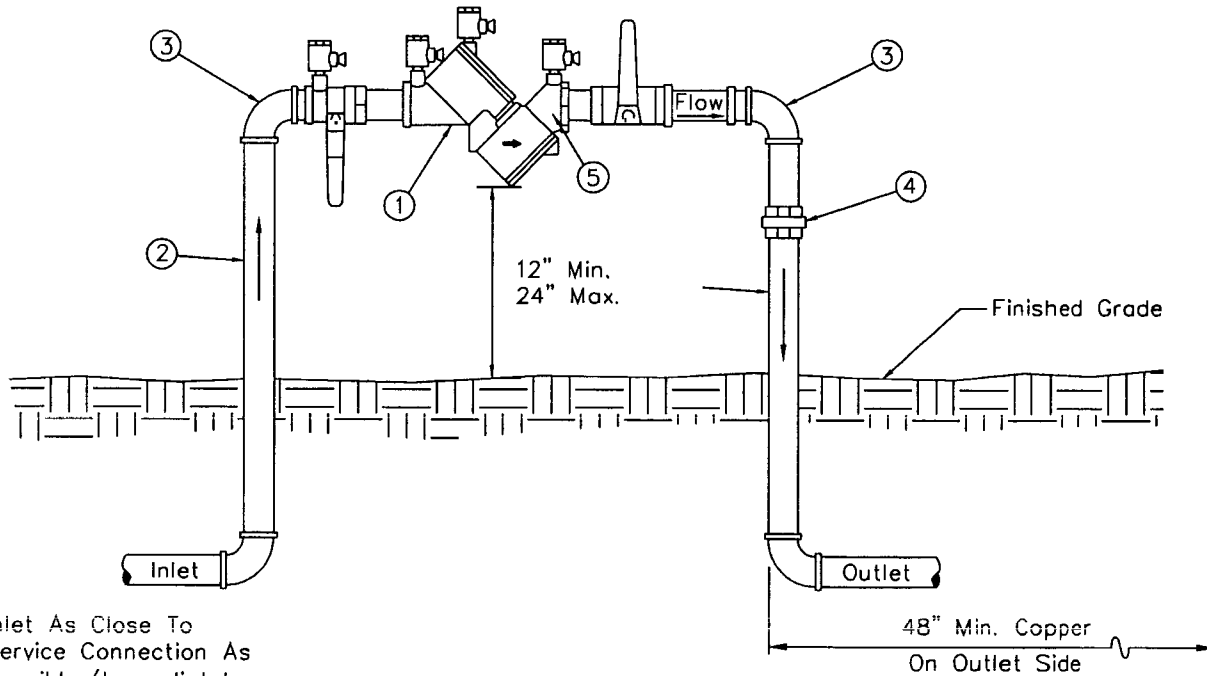

Inlet As Close To Service Connection As Possible (Immediately After Water Meter).
Copper On Inlet Side.

LIST OF MATERIALS

- ① Approved double check valve backflow prevention assembly, ball valves included.
- ② Pipe spool, type "L" hard copper, 3/4" thru 2 1/2".
- ③ 90° ell, copper, 3/4" thru 2 1/2".
- ④ Pipe union, brass or copper.
- ⑤ Test cocks with brass plugs or adaptors with caps installed. (4 required)

GENERAL NOTES

- 1. Backflow assemblies must be tested by a certified tester that is recognized by the City of Scottsdale.
- 2. Copper fittings shall be connected with lead free solder joints.
- 3. Finished grade underneath the backflow preventer shall be at 95% compaction.
- 4. All nipples to be copper or brass.
- 5. Piping under the City right of way must be type "K" copper.
- 6. Call for underground inspection before backfilling trench.
- 7. Vertical installations of assemblies on fire sprinkler systems are allowed using assemblies approved for use in the vertical position on fire systems.
- 8. Approvals for backflow assemblies must have Seal Approval from the American Society of Sanitation Engineers. Backflow assemblies installed on fire suppression systems must also have approval from Underwriters Laboratories and/or Factory Mutual Research Corporation.

DETAIL NO.
2352

City of Scottsdale
Standard Details

APPROVED BY:
Scottsdale Standards & Specifications Committee

DOUBLE CHECK VALVE BACKFLOW PREVENTION ASSEMBLY
FOR ASSEMBLIES 3/4 INCH THRU 2 1/2 INCHES

DETAIL NO.
2352

REVISED 5/05/04

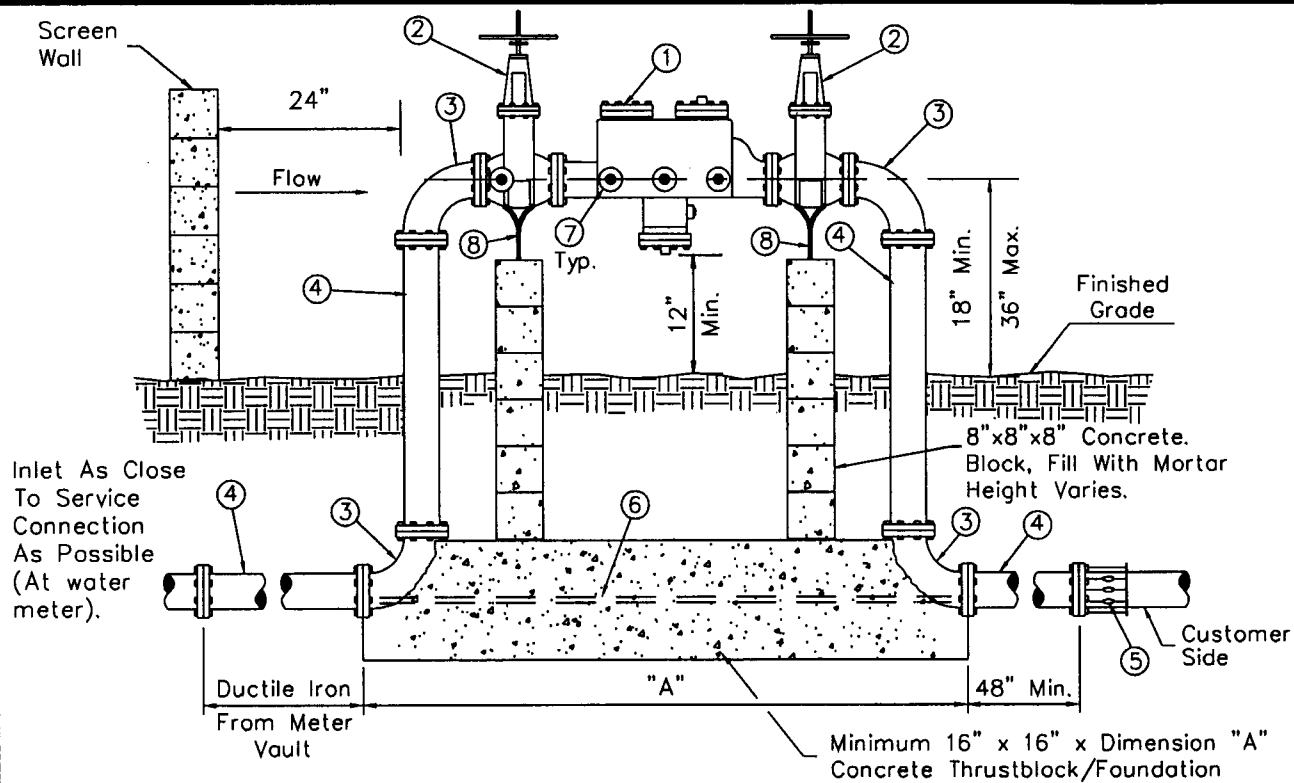

GENERAL NOTES

1. Backflow assemblies must be tested by a certified tester that is recognized by the City of Scottsdale.
2. Backflow preventers shall be painted light tan or a color to match the building. Do not paint the name plate or any brass parts on the assembly.
3. For backflow preventers requiring guard posts see Detail 2356. Backflow preventers enclosed by screening shall maintain a 24 inch clearance around the assembly.
4. Finished grade underneath the backflow preventer shall be at 95% compaction.
5. Backflow preventers on fire lines may require tamper switches on the shut off valves. Contact City Of Scottsdale Plan Review, Fire Dept.
6. Call for underground inspection before backfilling trench.
7. Approvals for backflow assemblies must have Seal Approval from the American Society of Sanitation Engineers. Backflow assemblies installed on fire suppression systems must also have approval from Underwriters Laboratories and/or Factory Mutual Research Corporation.

LIST OF MATERIALS

- | | |
|--|---|
| <ol style="list-style-type: none"> ① Approved reduced pressure principle backflow prevention assembly. ② Resilient seated gate valve. O.S. & Y. (fire line connection). N.R.S. (non fire line) ③ 90° ell. Flanged D.I.P. 3" thru 10", Mega Lug or approved equal may be used on underground joints. ④ Pipe spool. Flanged D.I.P. 3" thru 10", Mega Lug or approved equal may be used on underground joints. ⑤ Flanged adapter (when required) | <ol style="list-style-type: none"> ⑥ 3/4" zinc coated threaded rod, (5/8" rod on 3" to 4" sizes), bolt to flanges as shown, typical both sides. ⑦ Test cocks with brass plugs or adaptors with caps installed. (4 required) ⑧ Adjustable metal pipe supports and concrete block supports with 1" adjusting rod and nut on assemblies 4" and larger. Install above grade. |
|--|---|

DETAIL NO.
2353

**City of Scottsdale
Standard Details**

APPROVED BY:
**Scottsdale Standards &
Specifications Committee**

**REDUCED PRESSURE PRINCIPLE BACKFLOW PREVENTION
ASSEMBLY FOR ASSEMBLIES 3 INCHES THRU 10 INCHES**

DETAIL NO.
2353

REVISED 5/05/04

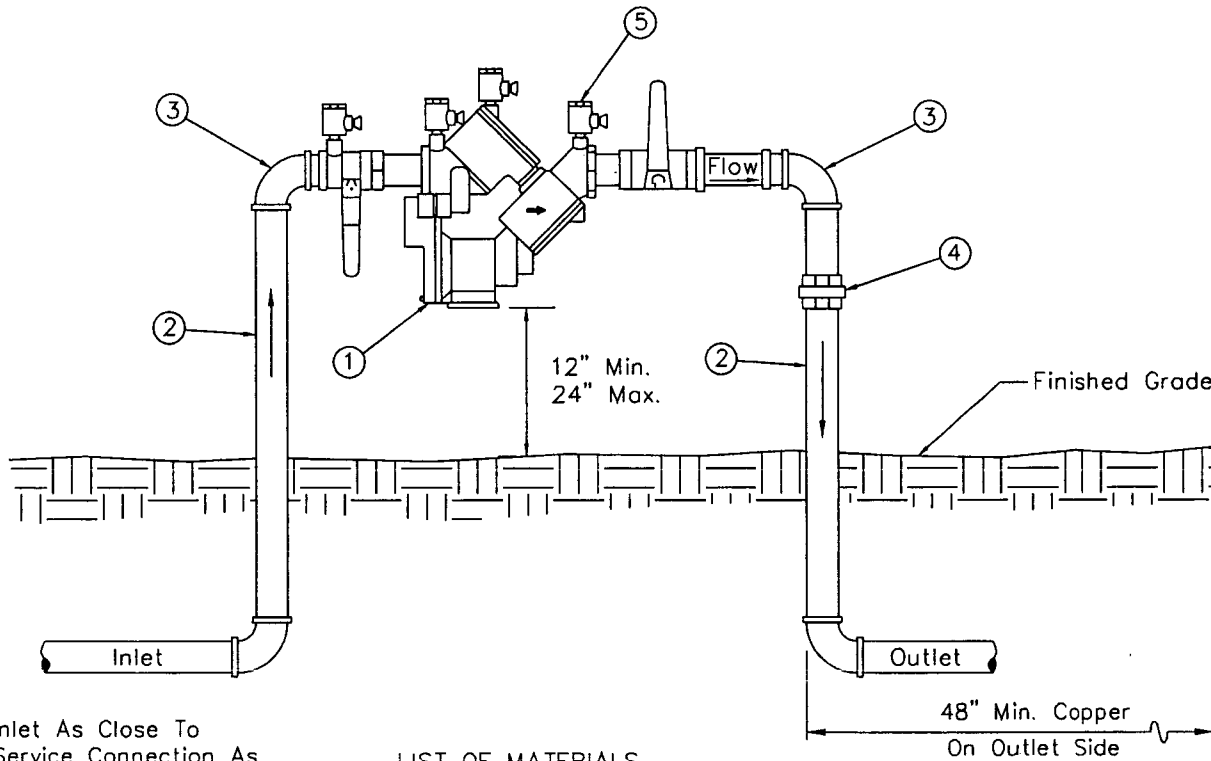

Inlet As Close To Service Connection As Possible (Immediately After Water Meter).
Copper On Inlet Side.

LIST OF MATERIALS

- ① Approved reduced pressure principle backflow prevention assembly, ball valves included.
- ② Pipe spool, type "L" hard copper, 3/4" thru 2 1/2".
- ③ 90° ell, copper, 3/4" thru 2 1/2".
- ④ Pipe union, brass or copper.
- ⑤ Test cocks with brass plugs or adaptors with caps installed. (4 Required)

GENERAL NOTES

- 1. Backflow assemblies must be tested by a certified tester that is recognized by the City of Scottsdale.
- 2. Copper fittings shall be connected with lead free solder joints.
- 3. Finished grade underneath the backflow preventer shall be at 95% compaction.
- 4. All nipples to be copper or brass.
- 5. Piping under the City right of way must be type "K" copper.
- 6. Call for underground inspection before backfilling trench.
- 7. Approvals for backflow assemblies must have Seal Approval from the American Society of Sanitation Engineers. Backflow assemblies installed on fire suppression systems must also have approval from Underwriters Laboratories and/or Factory Mutual Research Corporation.

DETAIL NO.
2354

City of Scottsdale
Standard Details

APPROVED BY:
Scottsdale Standards & Specifications Committee

REDUCED PRESSURE PRINCIPLE BACKFLOW PREVENTION ASSEMBLY FOR ASSEMBLIES 3/4 INCH THRU 2 1/2 INCHES

DETAIL NO.
2354

REVISED 5/05/04

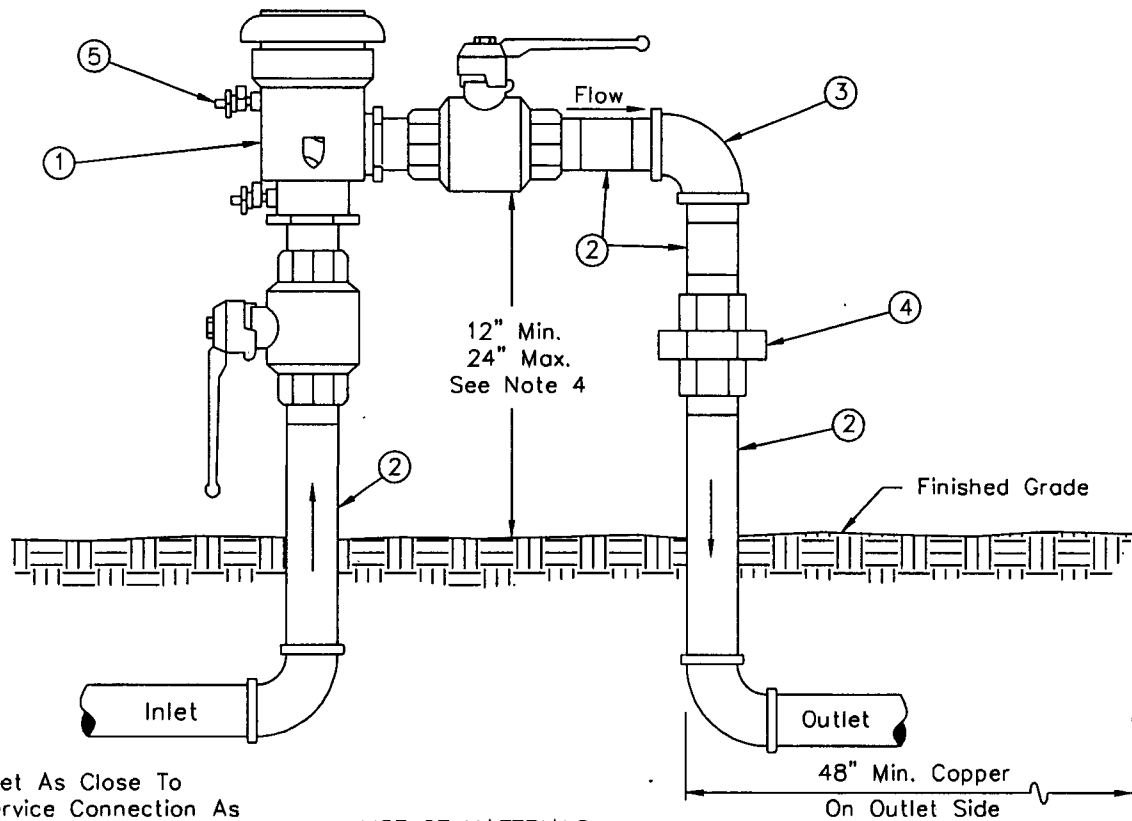

Inlet As Close To Service Connection As Possible (Immediately After Water Meter). Copper On Inlet Side.

LIST OF MATERIALS

- ① Approved pressure vacuum breaker assembly, ball valves included.
- ② Pipe spool, type "L" hard copper, 1/2" thru 2".
- ③ 90° ell, copper, 1/2" thru 2".
- ④ Pipe union, brass or copper.
- ⑤ Test cocks with brass plugs or adaptors with caps installed. (2 required)

GENERAL NOTES

- 1. Backflow assemblies must be tested by a certified tester that is recognized by the City of Scottsdale.
- 2. Pressure vacuum breakers must be installed at least 12" above all downstream piping.
- 3. If this distance exceeds 24 inches, a reduced pressure principle backflow prevention assembly must be utilized. See Detail 2354.
- 4. Copper fittings shall be connected with lead free solder joints.
- 5. Finished grade underneath the backflow preventer shall be at 95% compaction.
- 6. All nipples to be copper or brass.
- 7. Piping under the City right of way must be type "K" copper.
- 8. Call for underground inspection before backfilling trench.
- 9. Approvals for backflow assemblies must have Seal Approval from the American Society of Sanitation Engineers.

DETAIL NO.
2355

**City of Scottsdale
Standard Details**

APPROVED BY:
**Scottsdale Standards &
Specifications Committee**

**PRESSURE VACUUM BREAKER ASSEMBLY
FOR ASSEMBLIES 1/2 INCH THRU 2 INCHES**

DETAIL NO.
2355

REVISED 2/09/99

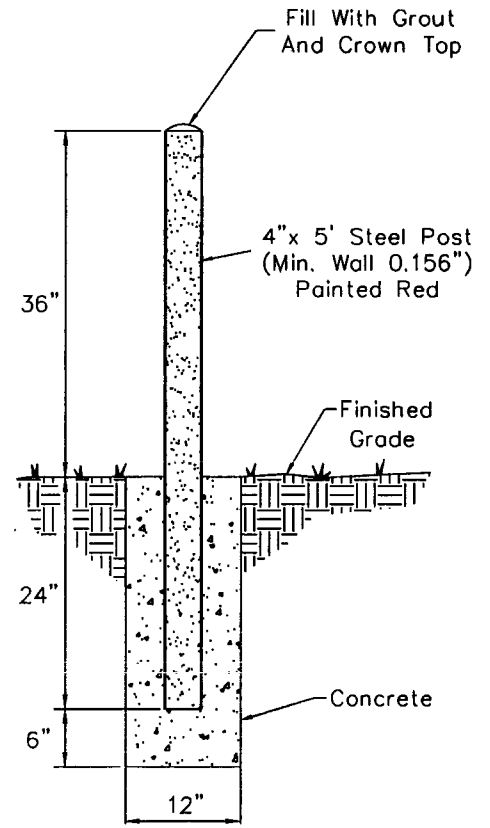
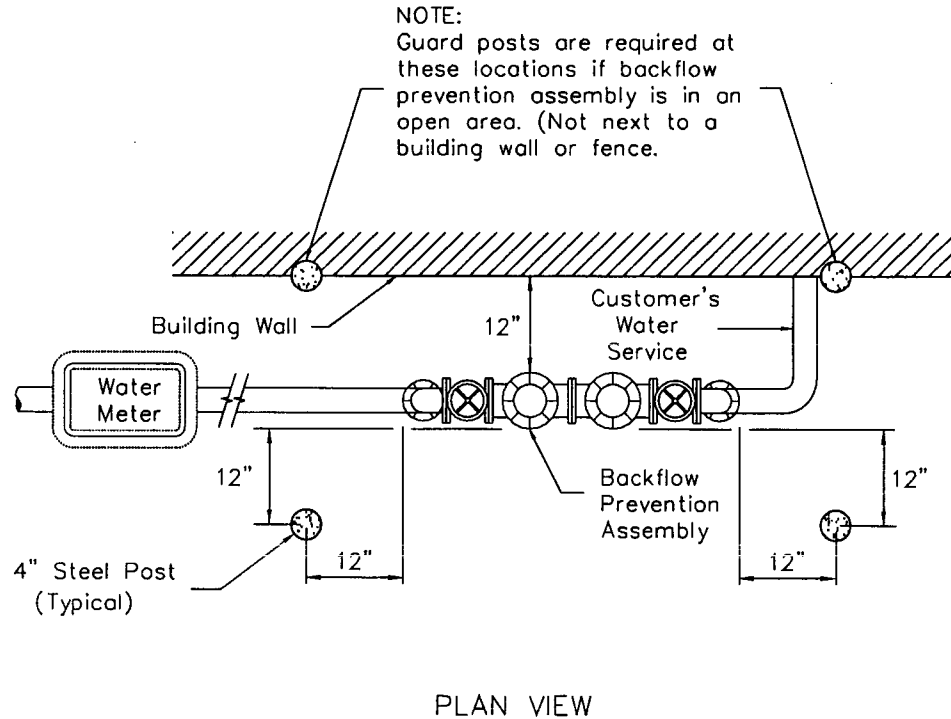

DETAIL NO.
2356

City of Scottsdale
Standard Details

APPROVED BY:
Scottsdale Standards & Specifications Committee

GUARD POSTS FOR BACKFLOW PREVENTION ASSEMBLIES

DETAIL NO.
2356

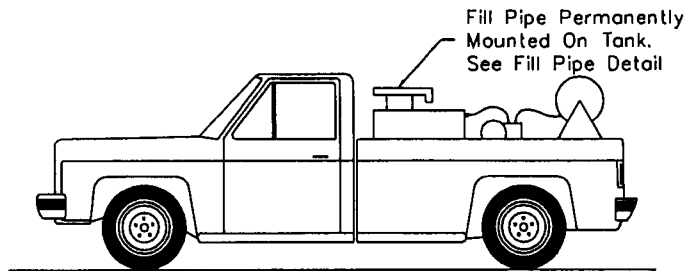

PESTICIDE APPLICATOR TRUCK

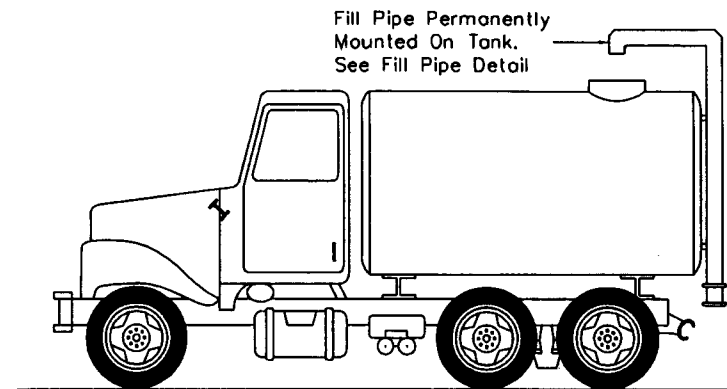

WATER TRUCK

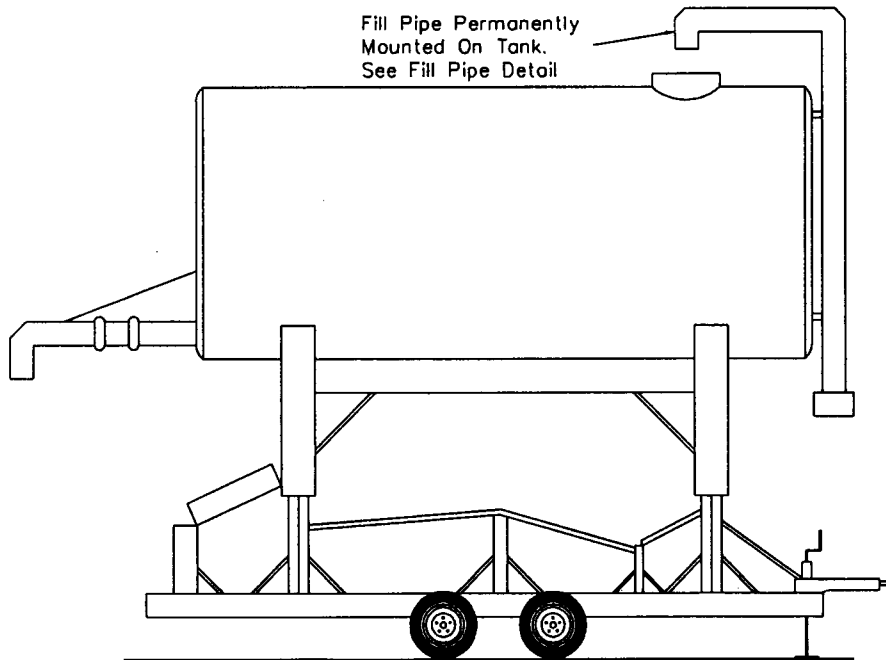

ELEVATED TANK

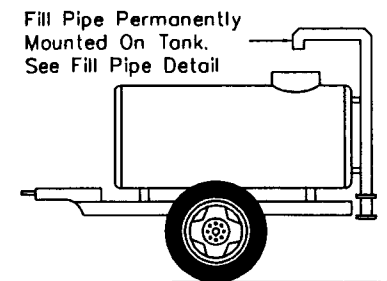
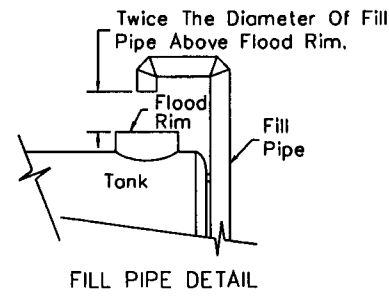

WATER WAGON

DETAIL NO.
2357

**City of Scottsdale
Standard Details**

APPROVED BY:
**Scottsdale Standards &
Specifications Committee**

**FILL PIPE DETAILS FOR PORTABLE TANKS WITH
AIR GAP SEPARATION**

DETAIL NO.
2357

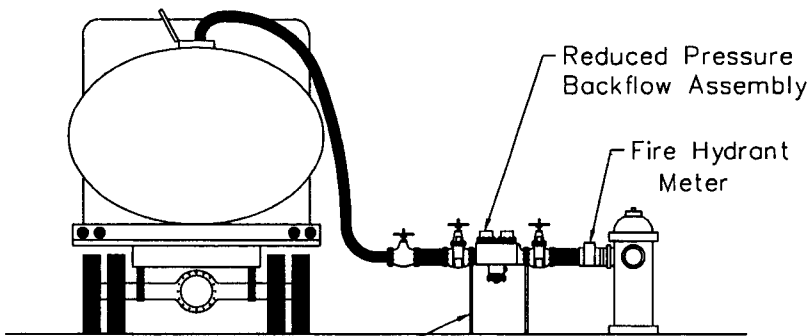

Supports Required

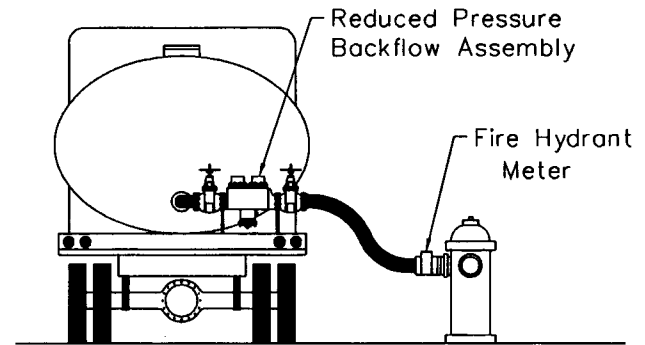

TANK TRUCKS

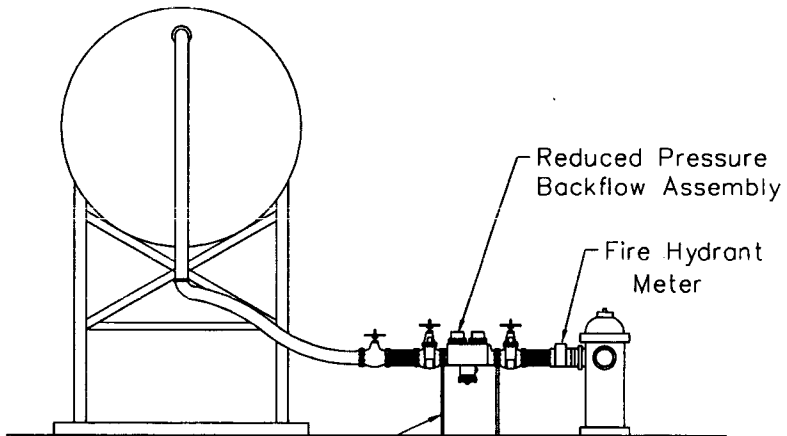

Supports Required

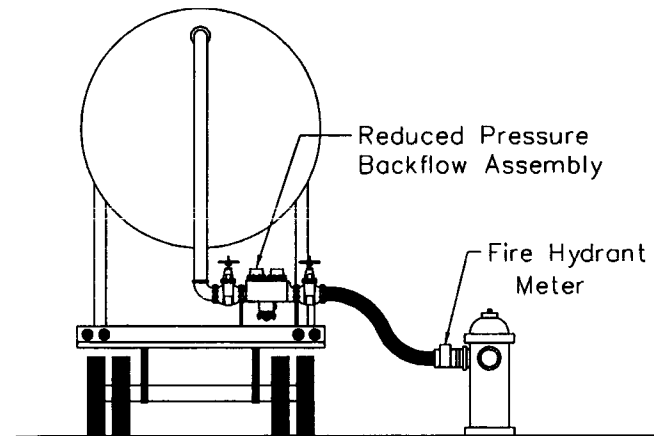

ELEVATED TANKS

DETAIL NO.
2358

**City of Scottsdale
Standard Details**

APPROVED BY:
**Scottsdale Standards &
Specifications Committee**

**BACKFLOW PREVENTION METHOD FOR PORTABLE TANKS
WITH NO AIR GAP SEPARATION**

DETAIL NO.
2358

REVISED 5/05/04

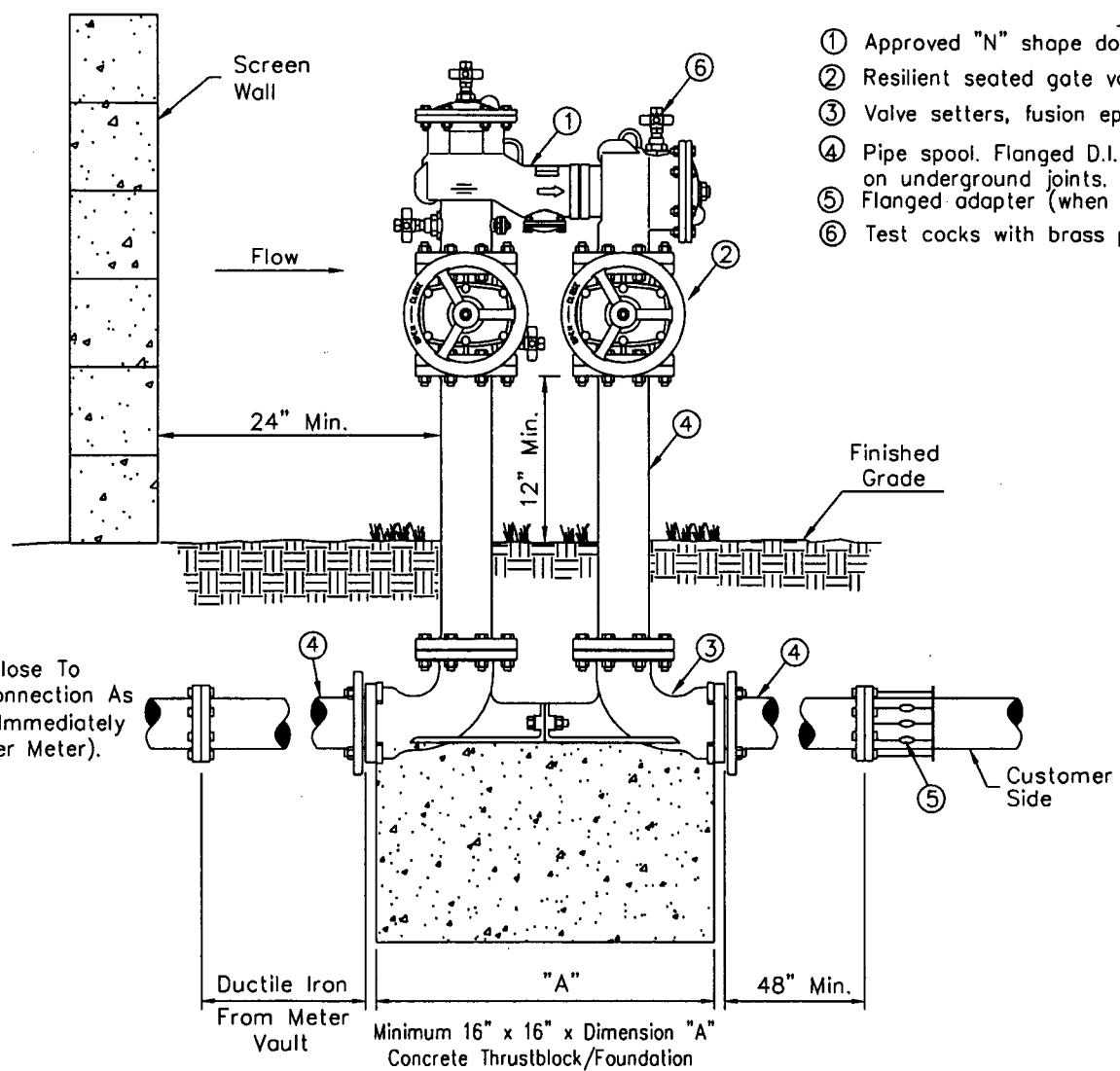

LIST OF MATERIALS

- ① Approved "N" shape double check valve backflow prevention assembly.
- ② Resilient seated gate valve. O.S. & Y. (fire line connection) N.R.S. (non fire line)
- ③ Valve setters, fusion epoxy coated ductile iron, plated nuts and bolts. (2 required)
- ④ Pipe spool. Flanged D.I.P. 3" thru 10", Mega Lug or approved equal may be used on underground joints.
- ⑤ Flanged adapter (when required)
- ⑥ Test cocks with brass plugs or adaptors with caps installed. (4 required)

GENERAL NOTES

1. Backflow backflow assemblies must be tested by a certified tester that is recognized by the City of Scottsdale.
2. Backflow preventers shall be painted light tan or a color to match the building. Do not paint the name plate or any brass parts on the assembly.
3. For backflow preventers requiring guard posts see Detail 2356. Backflow preventers enclosed by screening shall maintain a 24 inch clearance around the assembly.
4. Finished grade underneath the backflow preventer shall be at 95% compaction.
5. Backflow preventers on fire lines may require tamper switches on the shut off valves. Contact City Of Scottsdale Plan Review, Fire Dept.
6. Call for underground inspection before backfilling trench.
7. Seal Approval from the American Society of Sanitation Engineers. Backflow assemblies installed on fire suppression systems must also have approval from Underwriters Laboratories and/or Factory Mutual Research Corporation.

DETAIL NO.
2359

**City of Scottsdale
Standard Details**

APPROVED BY:
**Scottsdale Standards &
Specifications Committee**

**"N" SHAPED DOUBLE CHECK VALVE BACKFLOW PREVENTION
ASSEMBLY FOR ASSEMBLIES 3 INCHES THRU 10 INCHES**

DETAIL NO.
2359

REVISED 5/05/04

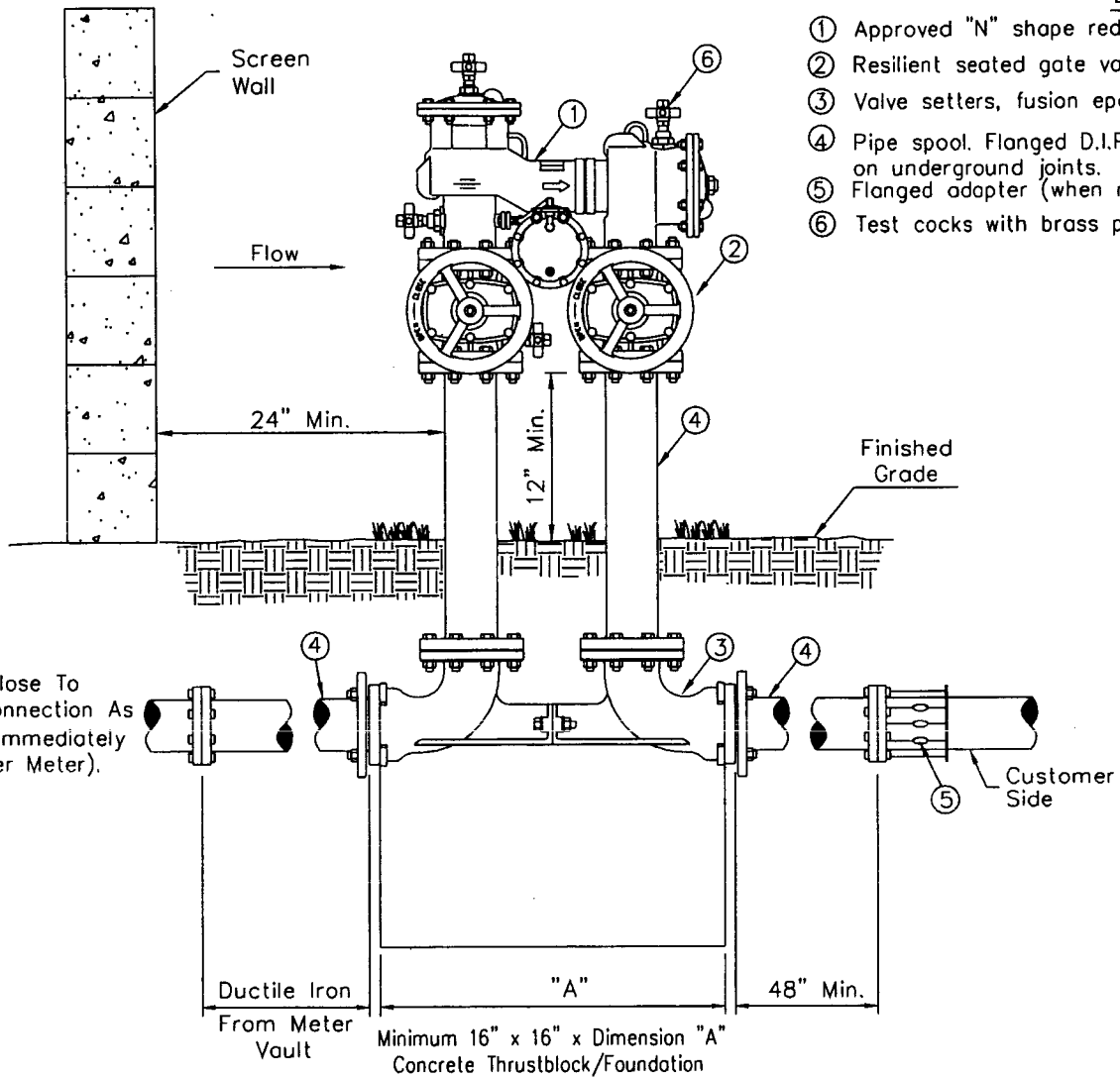

LIST OF MATERIALS

- ① Approved "N" shape reduced pressure principle backflow prevention assembly.
- ② Resilient seated gate valve. O.S. & Y. (fire line connection) N.R.S. (non fire line)
- ③ Valve setters, fusion epoxy coated ductile iron, plated nuts and bolts. (2 required)
- ④ Pipe spool. Flanged D.I.P. 3" thru 10", Mega Lug or approved equal may be used on underground joints.
- ⑤ Flanged adapter (when required)
- ⑥ Test cocks with brass plugs or adaptors with caps installed. (4 required)

GENERAL NOTES

1. Backflow backflow assemblies must be tested by a certified tester that is recognized by the City of Scottsdale.
2. Backflow preventers shall be painted light tan or a color to match the building. Do not paint the name plate or any brass parts on the assembly.
3. For backflow preventers requiring guard posts see Detail 2356. Backflow preventers enclosed by screening shall maintain a 24 inch clearance around the assembly.
4. Finished grade underneath the backflow preventer shall be at 95% compaction.
5. Backflow preventers on fire lines may require tamper switches on the shut off valves. Contact City Of Scottsdale Plan Review, Fire Dept.
6. Call for underground inspection before backfilling trench.
7. Approvals for backflow assemblies must have Seal Approval from the American Society of Sanitation Engineers. Backflow assemblies installed on fire supression systems must also have approval from Underwriters Laboratories and/or Factory Mutual Research Corporation.

DETAIL NO.
2360

**City of Scottsdale
Standard Details**

APPROVED BY:
**Scottsdale Standards &
Specifications Committee**

**"N" SHAPED REDUCED PRESSURE PRINCIPLE BACKFLOW PREVENTION
ASSEMBLY FOR ASSEMBLIES 3 INCHES THRU 10 INCHES**

DETAIL NO.
2360

REVISED 4/12/05

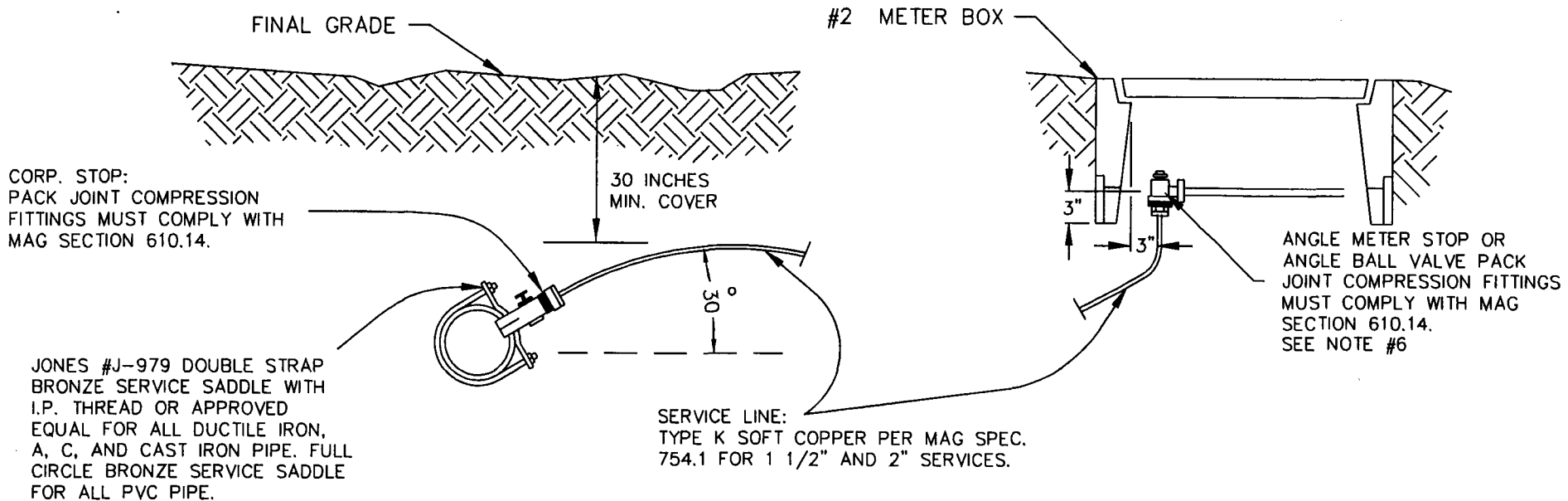

- NOTE:
1. All taps must be made using a service saddle.
 2. All service line sizes shall have the pack joint compression fittings for corp. stops and meter stops.
 3. Where a contractor is installing new water lines, he shall also install the water service connection. The installation shall include the service saddle, corp. stop, service pipe, appurtenant fittings, meter stop, concrete meter box and box cover, per M.A.G. Specifications.
 4. Copper service lines in the 1 1/2", and 2" sizes that cross streets will be one continuous piece. Only with the express written consent of Water & Wastewater Operations will joints be permitted under a road. When this occurs, pack joint fittings will be required; no soldered joints will be permitted.
 5. When all or part of a development is to be served by existing City of Scottsdale water mains, only authorized City of Scottsdale Water and Wastewater Operations personnel shall install the fire service connection.
 6. Fire Department Identification Tag is required. Water resistant tag shall be affixed to valve in meter box and shall state: "DO NOT CLOSE! Fire Sprinkler Supply Line".
 7. Rough grade shall be set to 1 1/2 inches below top of meter box. Final landscape grade shall be set flush to top of meter box.

DETAIL NO.
2362

**City of Scottsdale
Standard Details**

APPROVED BY:
**Scottsdale Standards &
Specifications Committee**

1 1/2" - 2" FIRE LINE CONNECTION

DETAIL NO.
2362

REVISED 6/15/91

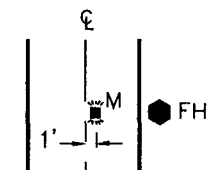

Midblock Local

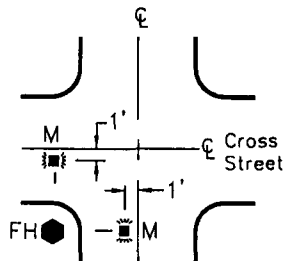

Local Cross Intersection

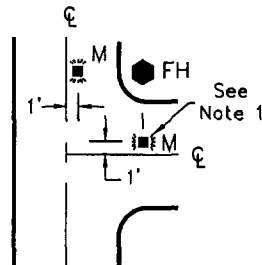

Local T Intersection

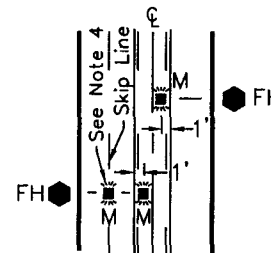

Midblock WITH CENTER LANE OR SKIP LINES

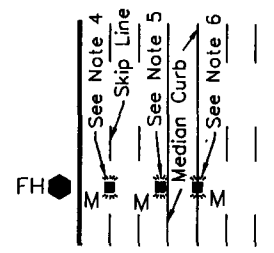

Midblock WITH RAISED MEDIAN

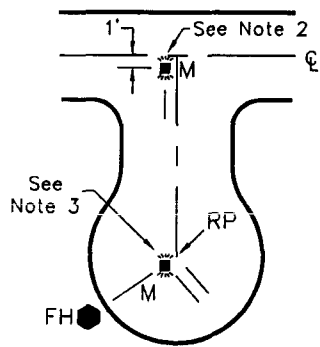

Cul-De-Sac Street

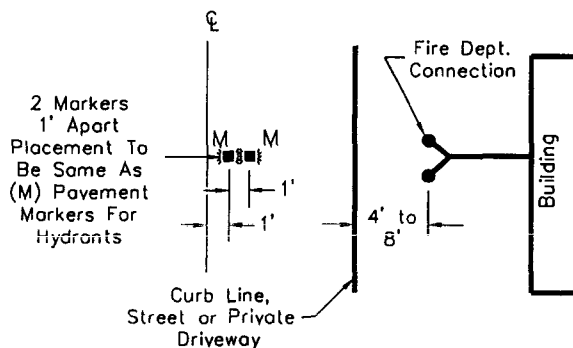

Fire Dept. Connection

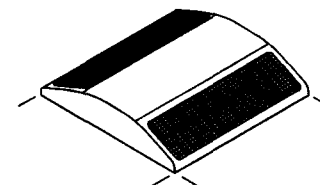

(M) Pavement Marker
(2-WAY REFLECTIVE BLUE)

NOTES:

1. Not Required on Dead End Streets Without Hydrants
2. Place on Hydrant Side of Centerline.
3. Not Required when Cul-De-Sac is Less Than 250'.
4. To Be Placed in Line With Skip Line.
5. Place on Gutter or Adjacent To Curb.
6. Place on Top of Curb. (This Location Optional)
7. Pavement Markers Shall Not Be Placed Within One Foot of A Point Line (Center to Center).

DETAIL NO.
2363

City of Scottsdale
Standard Details

APPROVED BY:
Scottsdale Standards & Specifications Committee

PAVEMENT MARKERS FOR FIRE HYDRANTS

DETAIL NO.
2363

REVISED 2/26/04

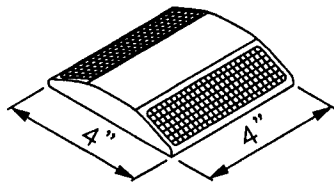

Type M Pavement Marker
(2-WAY REFLECTIVE BLUE)

DETAIL "A"

* NOTE:
Sidewalk And/Or 2"
Max. Ground Cover
Over Min. 6" ABC

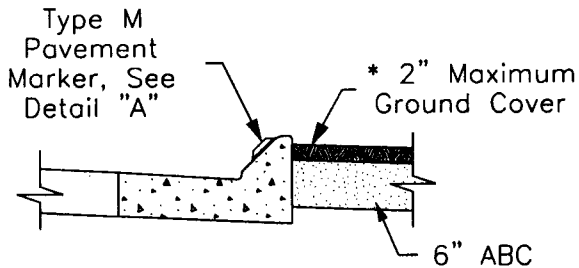

**TYPE "M" MOUNTABLE
CURB AND GUTTER**

DETAIL "B"

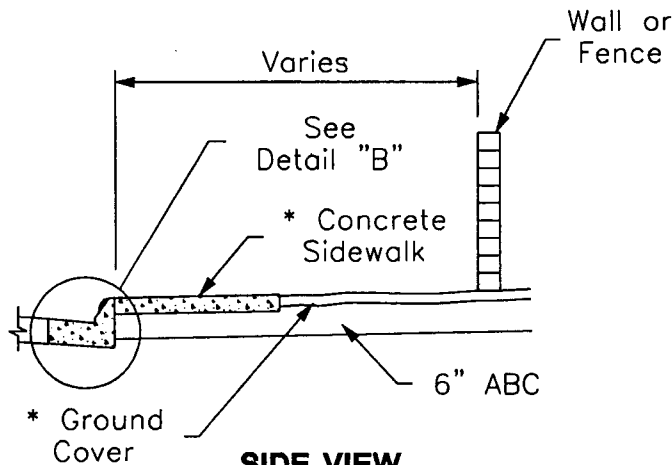

SIDE VIEW

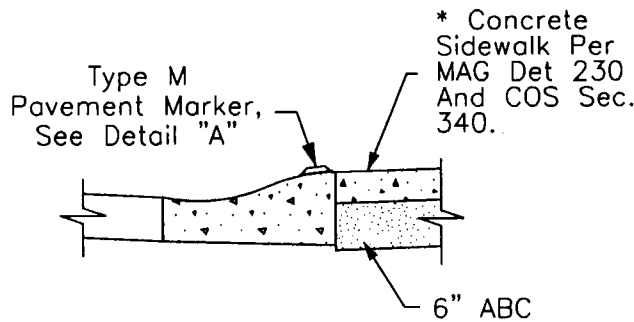

ROLL CURB

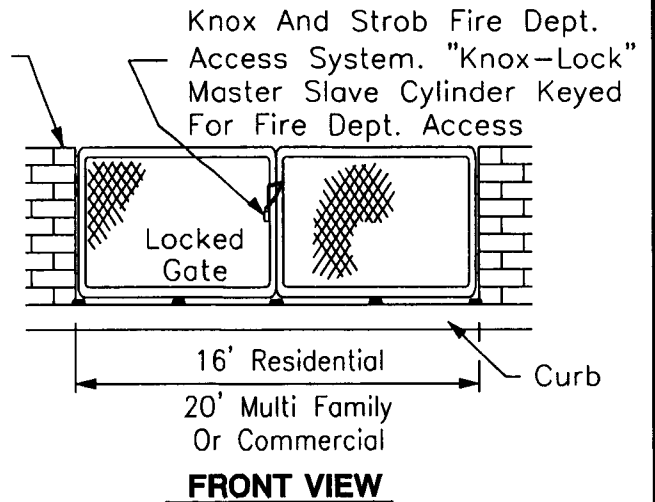

FRONT VIEW

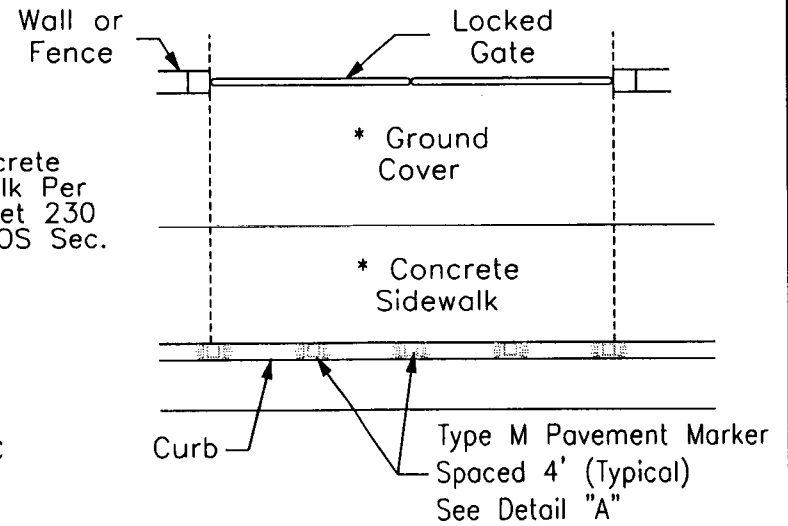

TOP VIEW

DETAIL NO.
2364

**City of Scottsdale
Standard Details**

APPROVED BY:
**Scottsdale Standards &
Specifications Committee**

FIRE AND EMERGENCY ACCESS AND DELINEATION

DETAIL NO.
2364

REVISED 2/26/04



NOTES:

1. At the beginning and end of the fire lane, the sign shall have a single headed arrow pointing in the direction the regulation is in effect. The intermediate signs shall have double headed arrows pointing in both directions.
2. The maximum spacing of the signs shall be 100', contingent upon Traffic Engineering's review and approval.
3. The signs shall be set at an angle of not less than 30° nor more than 45° with the curb or line of traffic flow
4. The clearance to the bottom of the sign shall be 7 feet. There shall be no other signs attached to the sign or the sign pole.
5. The sign plate shall be a minimum of 12" x 18" with a thickness of 0.80".
6. The sign face shall have a white, ASTM Type II (super engineering grade) reflective background with a red reflective legend. Use the standard sign face number R7-32 or equivalent incorporating additional information to complete the sign as shown above.

DETAIL NO.
2365

**City of Scottsdale
Standard Details**

APPROVED BY:
**Scottsdale Standards &
Specifications Committee**

FIRE LANE SIGN

DETAIL NO.
2365

REVISED: 4/30/04

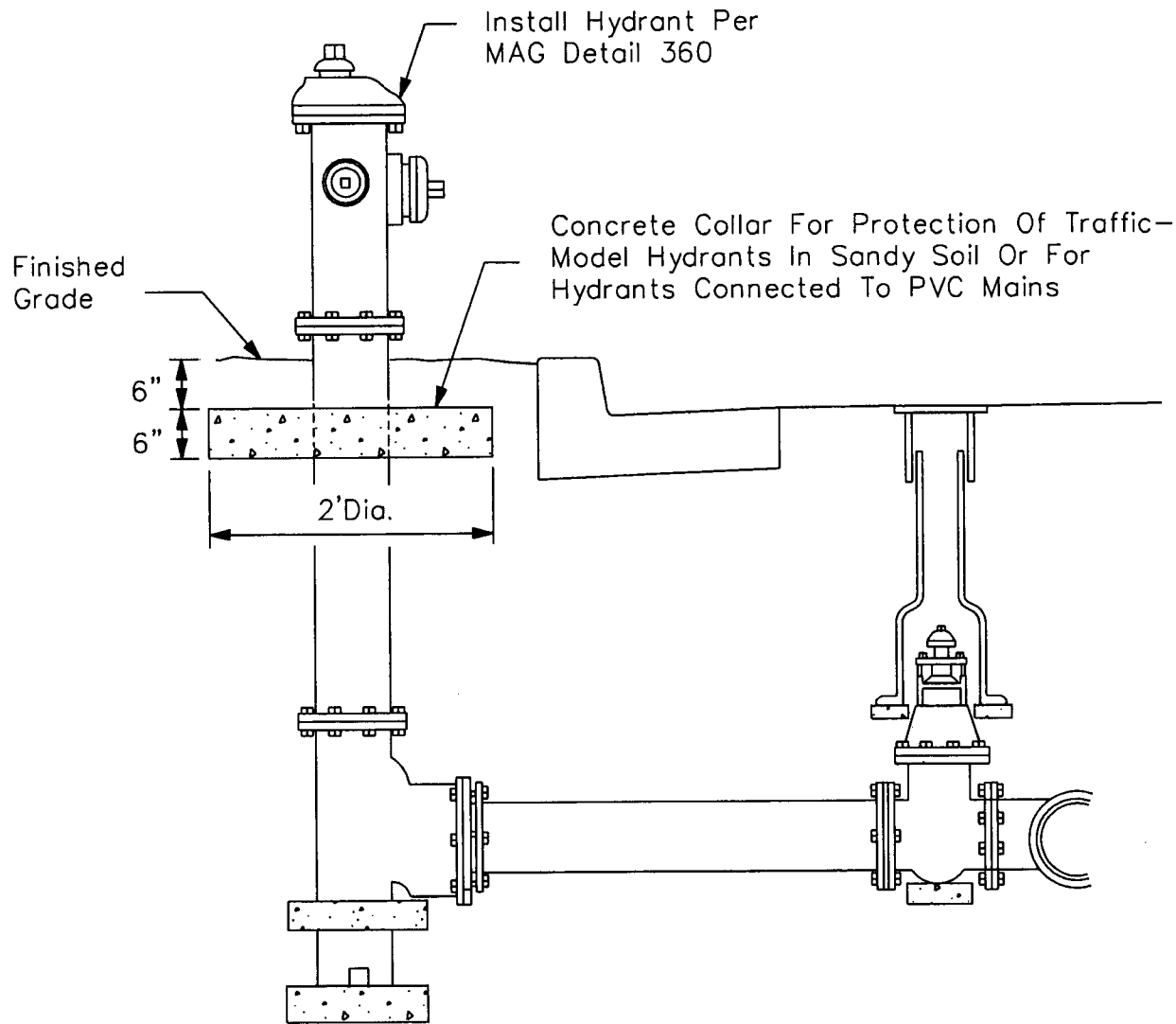

DETAIL NO.
2366

**City of Scottsdale
Standard Details**

APPROVED BY:
**Scottsdale Standards &
Specifications Committee**

CONCRETE COLLAR FOR FIRE HYDRANTS

DETAIL NO.
2366

GENERAL NOTES

1. Provide Building I.D. On Remote Fire Dept. Connection.
2. No Trees, Bushes Or Walls Within 5' Radius Of Fire Dept. Connection
3. If Fire Sprinkler Design Indicates Demand Of 1000 GPM Or Greater, The Underground Fire Dept. Connection Line Shall Be Increased To 6" Diameter With A Three Way 2 1/2" Fire Dept. Hose Connection
4. 4' Min. To Back Of Curb, or 2' Min To Back Of Sidewalk, or When No Curb, 4' Max. Outside The Clear Zone.

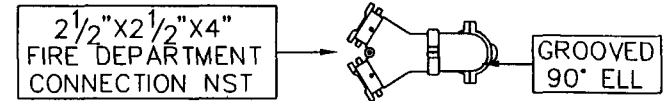

TOP VIEW

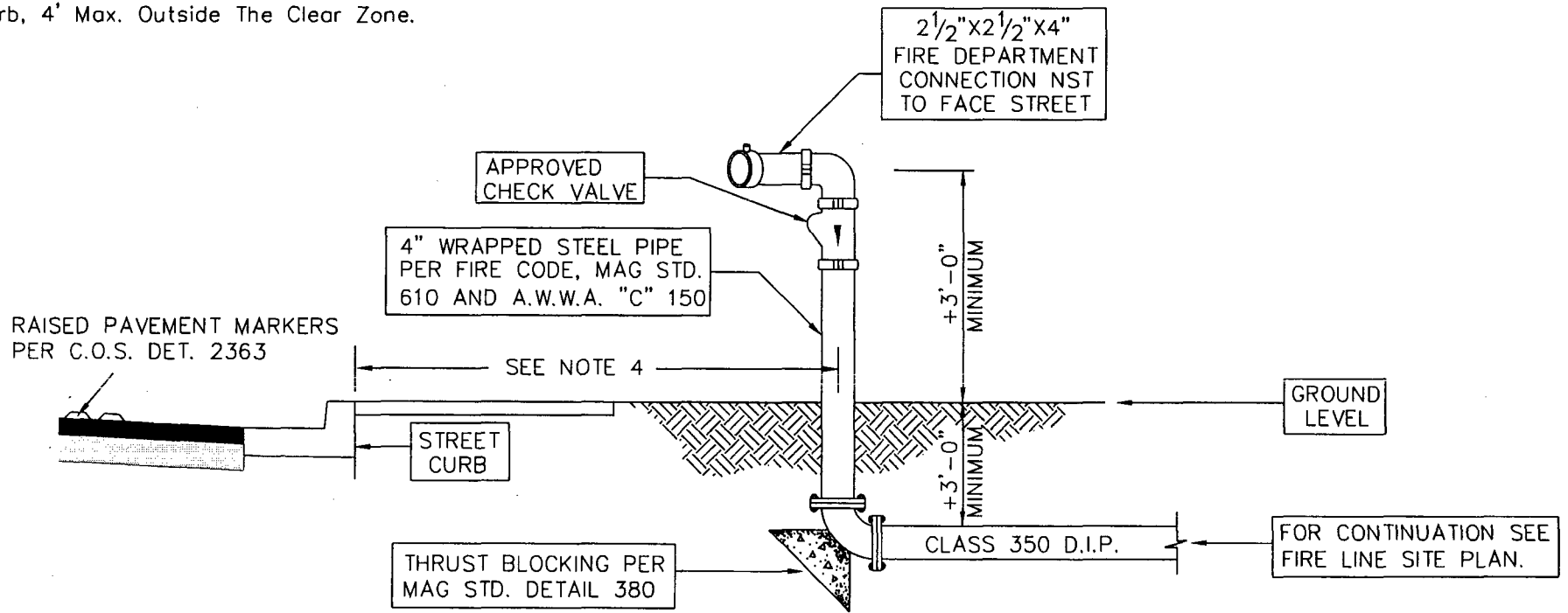

SIDE VIEW

REVISED 5/17/05

DETAIL NO. 2367	City of Scottsdale Standard Details	APPROVED BY: Scottsdale Standards & Specifications Committee	FIRE DEPARTMENT REMOTE SIAMESE CONNECTION	DETAIL NO. 2367
---------------------------	---	--	--	---------------------------

REVISED 5/17/05

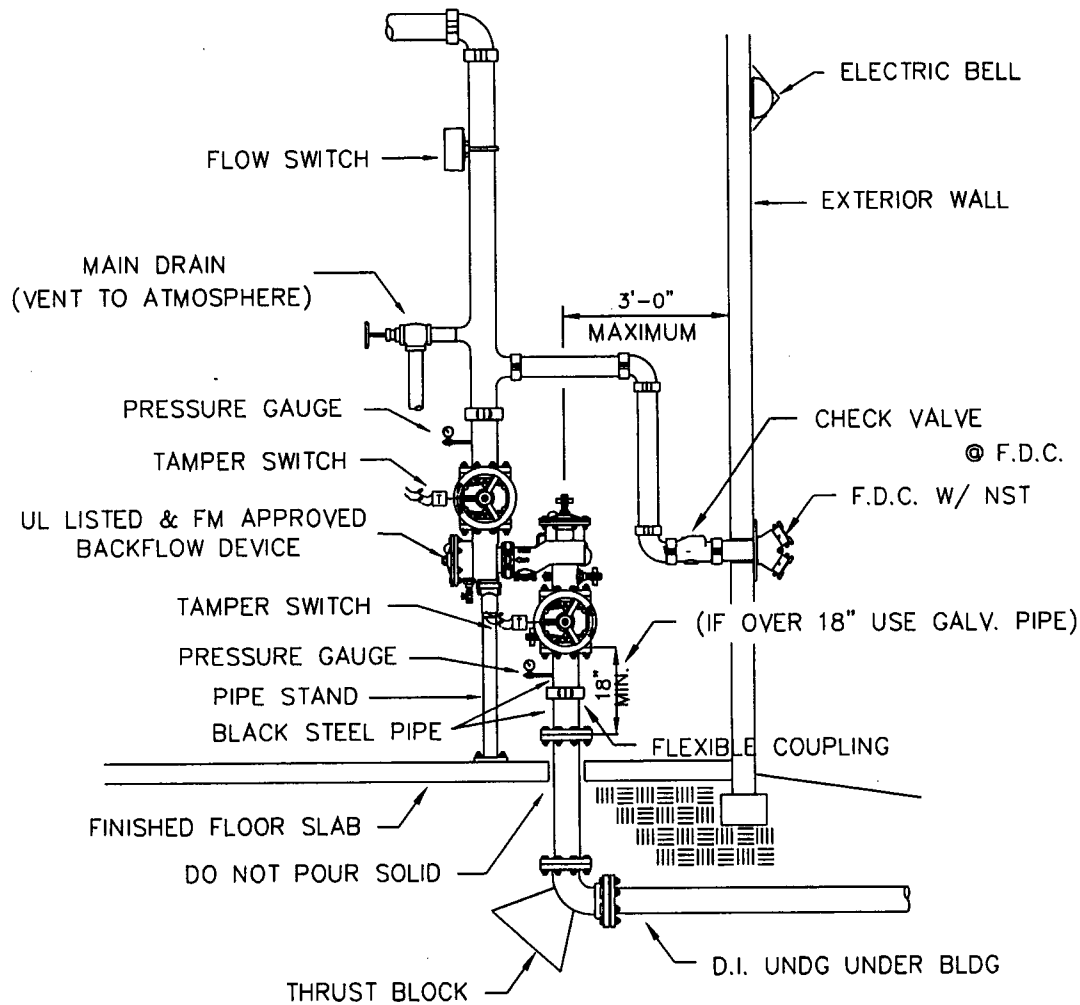

GENERAL NOTES

1. BACKFLOW PREVENTER SHALL BE TESTED FOR PROPER OPERATION PER CITY OF SCOTTSDALE REQUIREMENTS BY A CERTIFIED TESTER RECOGNIZED BY THE CITY, BEFORE A TEMPORARY CERTIFICATE OF OCCUPANCY IS ISSUED.
2. ADEQUATE CLEARANCE SHALL BE PROVIDED AROUND FIRE RISER. DIMENSIONS FROM FACE OF PIPE SHALL MEASURE A MINIMUM OF 12" OFF THE BACK WALL, 18" ON EACH SIDE AND 36" CLEAR IN FRONT WITH A FULL HEIGHT DOOR. THE FIRE LINE SHALL EXTEND A MAXIMUM OF 3' INTO THE BUILDING FROM INSIDE FACE OF WALL TO CENTER OF PIPE.
3. RISER SHALL BE HYDROSTATICALLY TESTED AT 200 PSI FOR TWO HOURS.
4. AT #1 & #4 TEST PORTS INSTALL A 1/2" BRASS NIPPLE, TEE & PLUGS W/ 1/2" x 1/4" MALE FLARED CONNECTION W/ CAP (INSTALL PRESSURE GAUGE ON TEE OUTLET)

DETAIL NO.
2368

**City of Scottsdale
Standard Details**

APPROVED BY:
**Scottsdale Standards &
Specifications Committee**

FIRE SPRINKLER RISER DETAIL - VERTICAL INSTALLATION #1

DETAIL NO.
2368

REVISED 5/17/05

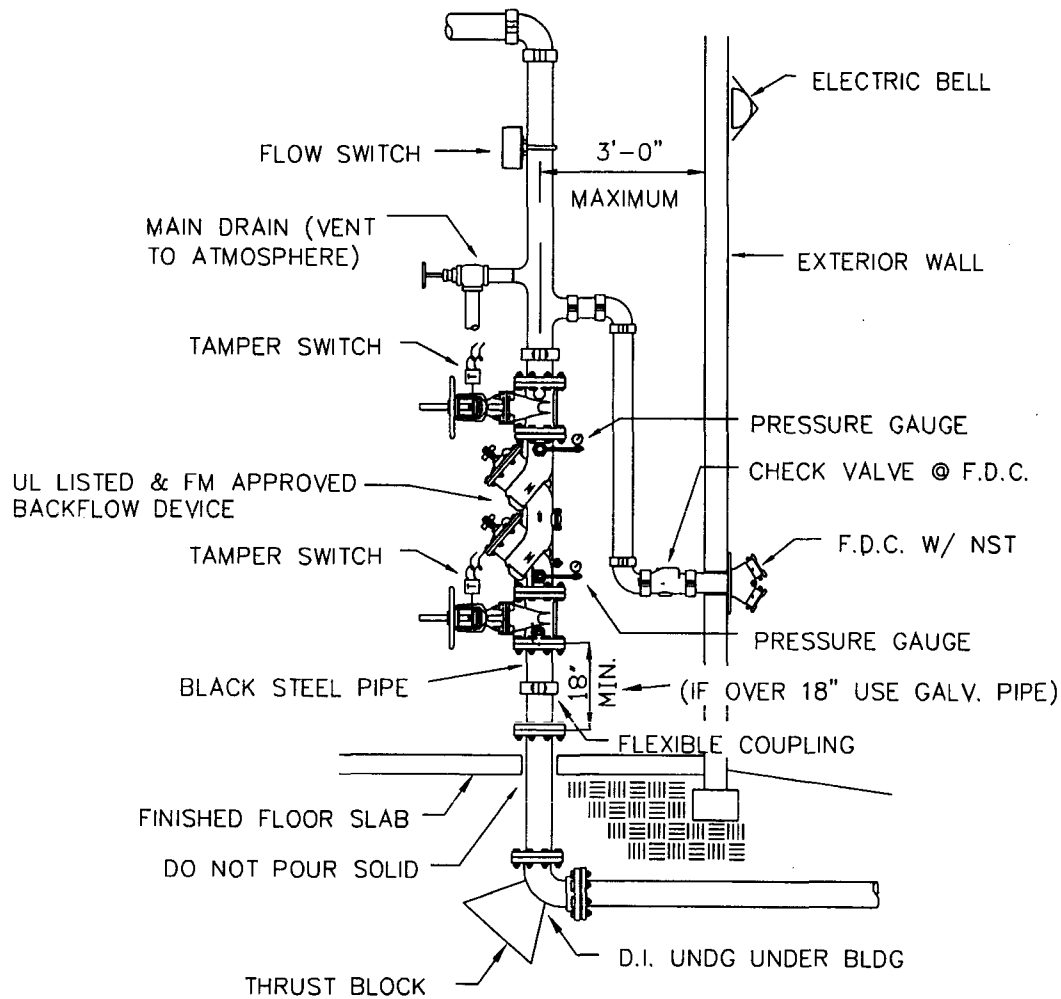

GENERAL NOTES

1. BACKFLOW PREVENTER SHALL BE TESTED FOR PROPER OPERATION PER CITY OF SCOTTSDALE REQUIREMENTS BY A CERTIFIED TESTER RECOGNIZED BY THE CITY, BEFORE A TEMPORARY CERTIFICATE OF OCCUPANCY IS ISSUED.
2. ADEQUATE CLEARANCE SHALL BE PROVIDED AROUND FIRE RISER. DIMENSIONS FROM FACE OF PIPE SHALL MEASURE A MINIMUM OF 12" OFF THE BACK WALL, 18" ON EACH SIDE AND 36" CLEAR IN FRONT WITH A FULL HEIGHT DOOR. THE FIRE LINE SHALL EXTEND A MAXIMUM OF 3' INTO THE BUILDING FROM INSIDE FACE OF WALL TO CENTER OF PIPE.
3. RISER SHALL BE HYDROSTATICALLY TESTED AT 200 PSI FOR TWO HOURS.
4. AT #1 & #4 TEST PORTS INSTALL A 1/2" BRASS NIPPLE, TEE & PLUGS W/1/2" x 1/4" MALE FLARED CONNECTION W/ CAP (INSTALL PRESSURE GAUGE ON TEE OUTLET)

DÉTAIL NO.
2369

City of Scottsdale
Standard Details

APPROVED BY:
Scottsdale Standards & Specifications Committee

FIRE SPRINKLER RISER DETAIL - VERTICAL INSTALLATION #2

DÉTAIL NO.
2369

REVISED 2/27/02

AIR RELEASE AND SHUT-OFF VALVE (REQUIRED ON ALL LINES UNLESS OTHERWISE APPROVED BY WATER RESOURCES DEPARTMENT).

DUCTILE IRON PIPE, PIPE SHALL COMPLY WITH MAG SPEC'S, SECTION 750 AND SHALL HAVE POLYETHYLENE WRAP CORROSION PROTECTION PER MAG SECTION 610.5

AIR RELEASE AND SHUT-OFF VALVE (REQUIRED ON ALL LINES UNLESS OTHERWISE APPROVED BY WATER RESOURCES DEPARTMENT).

RESILIENT WEDGE GATE VALVE

FINISH GRADE

3' MIN. FOR < 12" DIA.
4' MIN. FOR 12" DIA. OR LARGER

RESILIENT WEDGE GATE VALVE

CULVERT/STORM DRAIN OR LINED CHANNEL

ADAPTOR, AS REQ'D

RESTRAINED LENGTH PER PLAN OR MAG DET. 303-1&2 (TYP)

ARV

ARV

ADAPTOR, AS REQ'D

ARV

45° BEND

1' MIN. CLEAR

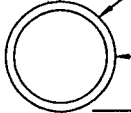

2'

24" MIN. SEPARATION

45° BEND

WATER LINE

NOTES:

- 1. THIS DETAIL PROVIDES SEPARATION & COVER REQUIREMENTS ONLY.
- 2. RESTRAINED JOINTS SHALL BE USED ON ALL BENDS AND FOR THE APPROPRIATE RESTRAINT LENGTH OF PIPE PER THE MANUFACTURERS SPECIFICATION.

DETAIL NO.
2370

**City of Scottsdale
Standard Details**

APPROVED BY:
**Scottsdale Standards &
Specifications Committee**

VERTICAL REALIGNMENT OF WATER MAINS

DETAIL NO.
2370

REVISED 8/29/96

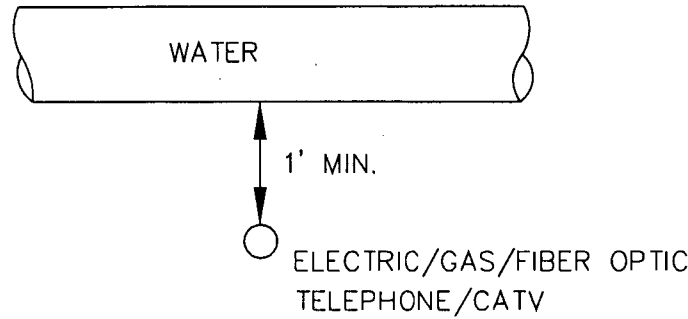
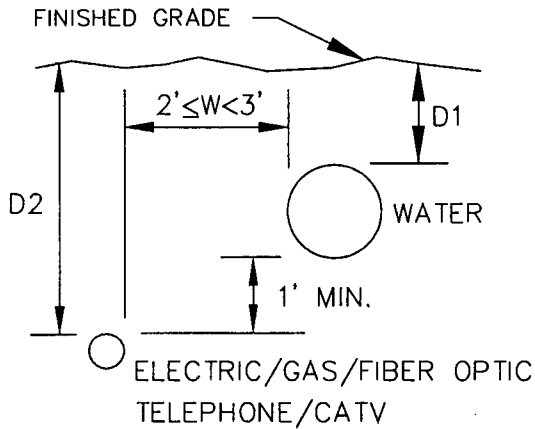

CROSSING

LEGEND

- D1 = 3' Min. for pipe < 12" dia
- D1 = 4' Min. for pipe ≥ 12" dia
- D2 = Minimum Cover
- W = Horizontal Separation

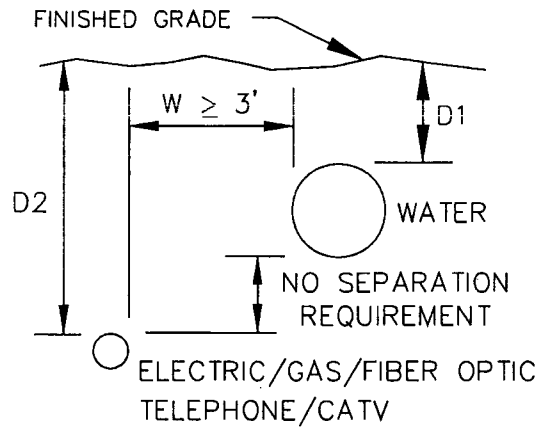

NOTES

1. Electric separation requirements are for primary electric conductors only. For service conductors see plans.
2. Primary electric, gas, telephone, cable TV or fiber optic lines shall not cross above a water line without written approval from the City's Water Resources Department. If this approval is obtained, a utility locator strip and ABC slurry conforming to COS Specifications Sec. 601.3.6 are required.

DETAIL NO. 2372

City of Scottsdale
Standard Details

APPROVED BY:
Scottsdale Standards & Specifications Committee

MINIMUM UTILITY SEPARATION REQUIREMENTS

DETAIL NO. 2372

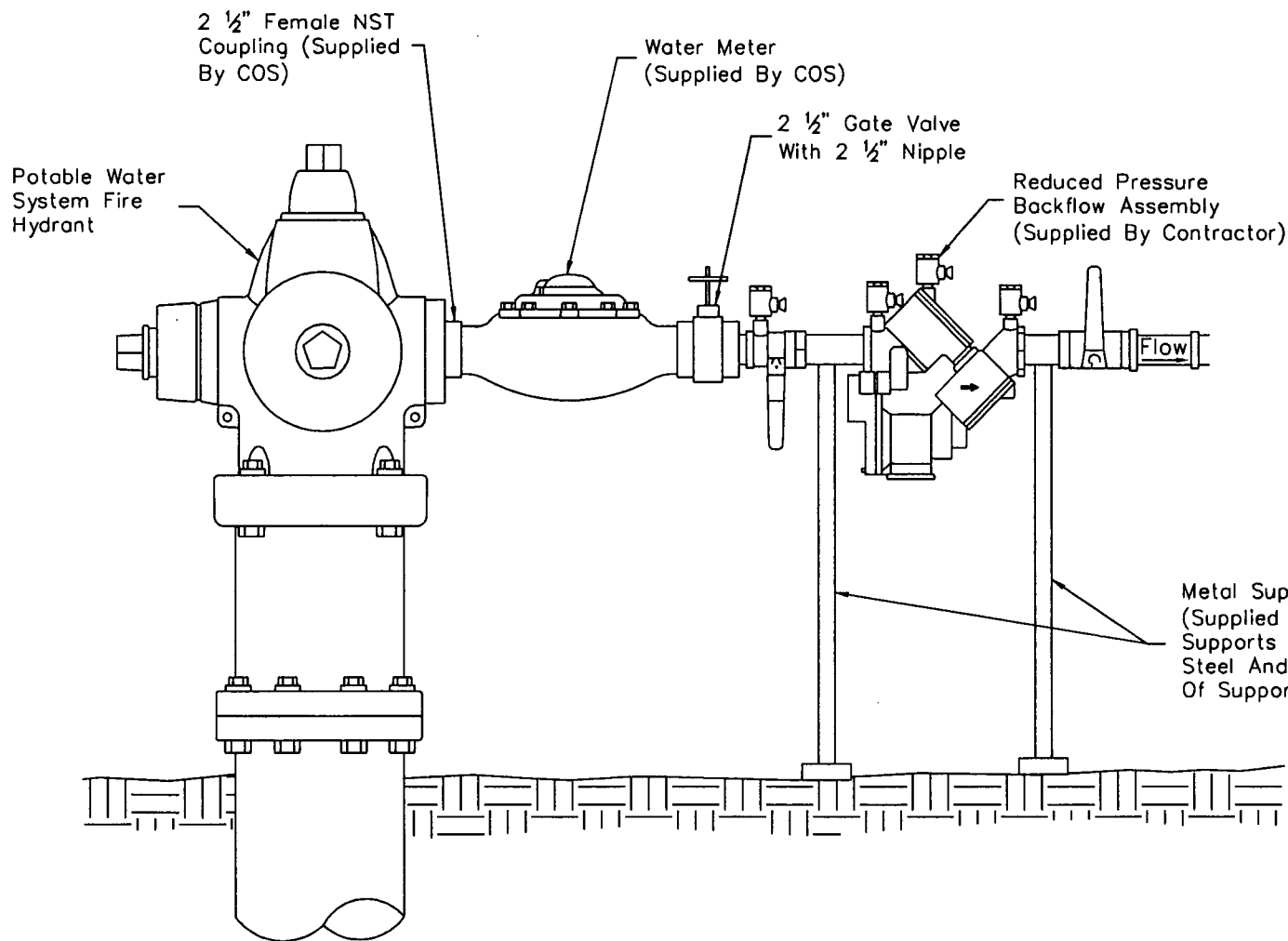

GENERAL NOTES

1. Backflow assembly shall be tested by a certified backflow assembly tester before using and also each time the meter is moved.
2. User must remove backflow assembly when hydrant meter is removed or relocated.
3. User is liable for any damage to the hydrant and all attachments to the hydrant.
4. User must use gate valve to control flow of water, not the hydrant valve assembly.
5. Call 480-312-5650 for questions.

DETAIL NO.
2380

**City of Scottsdale
Standard Details**

APPROVED BY:
**Scottsdale Standards &
Specifications Committee**

TEMPORARY WATER SUPPLY HYDRANT METER ASSEMBLY

DETAIL NO.
2380

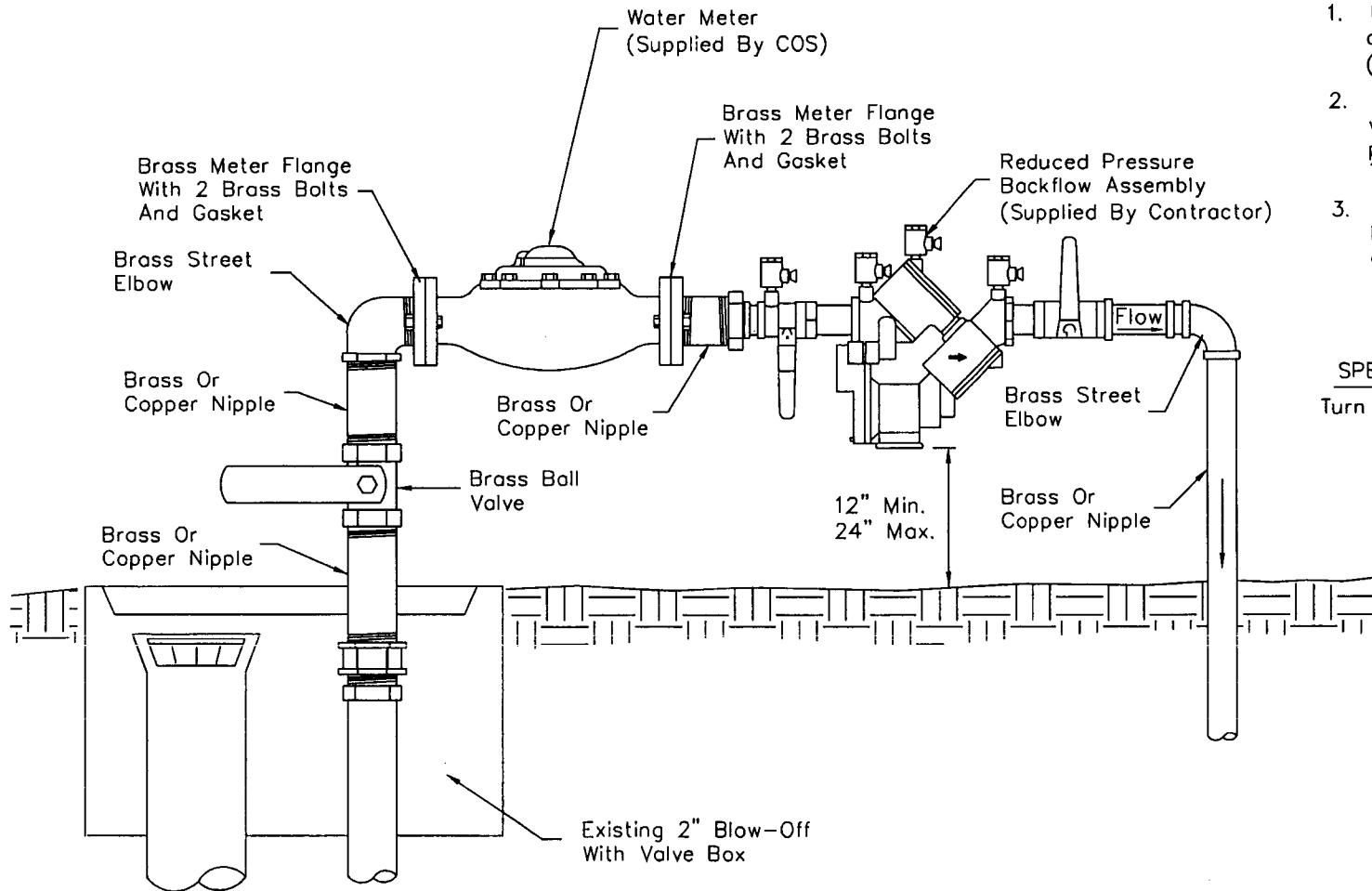

GENERAL NOTES

1. User must install City water meter above grade for temporary use. (One year maximum)
2. User must supply all fittings, piping, valves and approved reduced pressure principle backflow prevention assembly. The City shall supply the water meter.
3. Backflow assembly must be tested before use by a certified backflow assembly tester.

SPECIAL NOTE

Turn water on and off slowly.

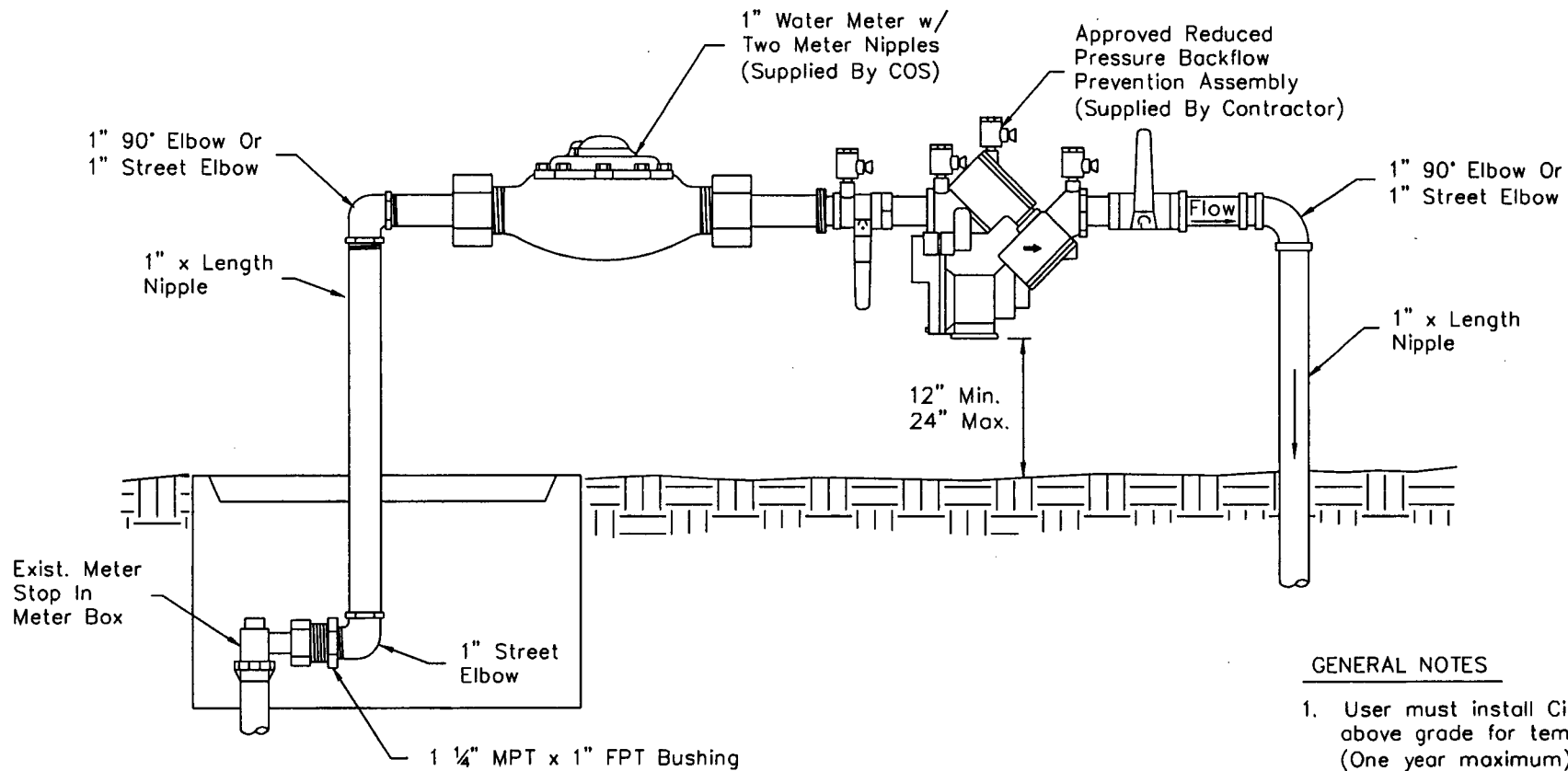

GENERAL NOTES

1. User must install City water meter above grade for temporary use. (One year maximum)
2. User must supply all fittings, nipples, valves and approved reduced pressure principle backflow prevention assembly. All fittings and nipples must be brass. The City shall supply the water meter.
3. Backflow assembly must be tested before use by a certified backflow assembly tester.

DETAIL NO.
2382

**City of Scottsdale
Standard Details**

APPROVED BY:
**Scottsdale Standards &
Specifications Committee**

TEMPORARY WATER SERVICE

DETAIL NO.
2382

REVISED 4/12/05

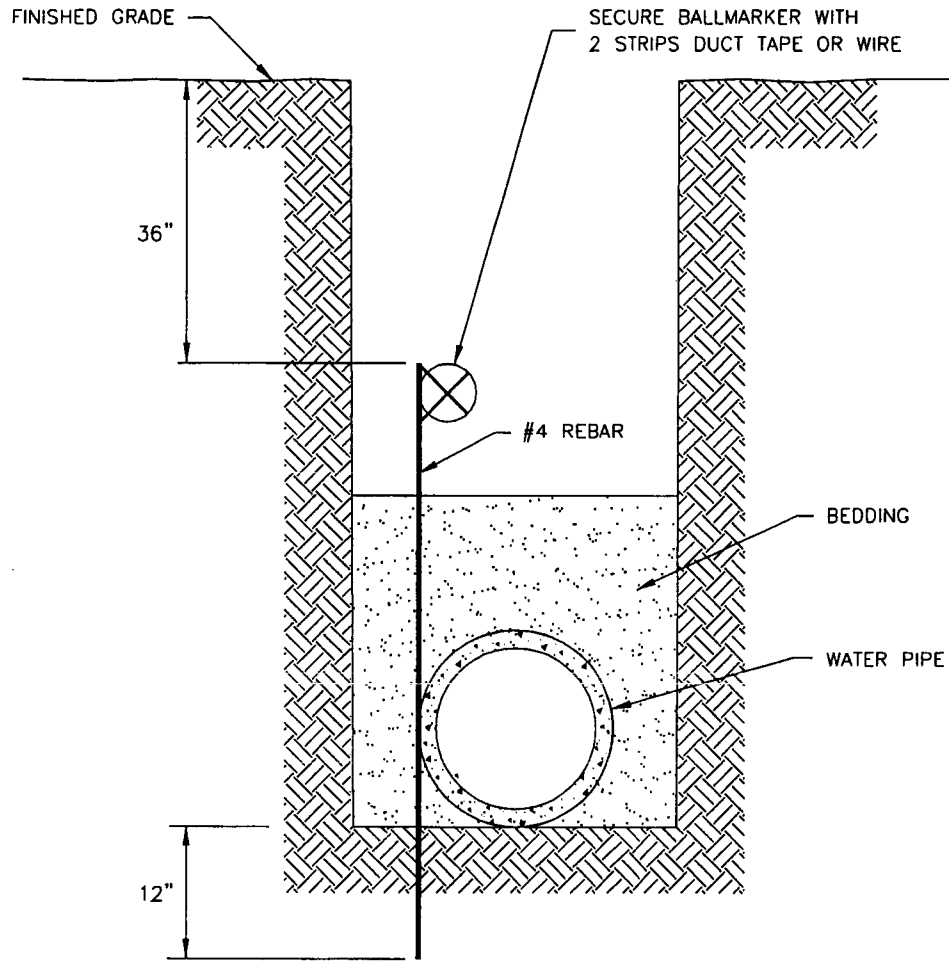

DETAIL NO.
2397

City of Scottsdale
Standard Details

APPROVED BY:
Scottsdale Standards & Specifications Committee

ELECTRONIC BALLMARKER PLACEMENT

DETAIL NO.
2397

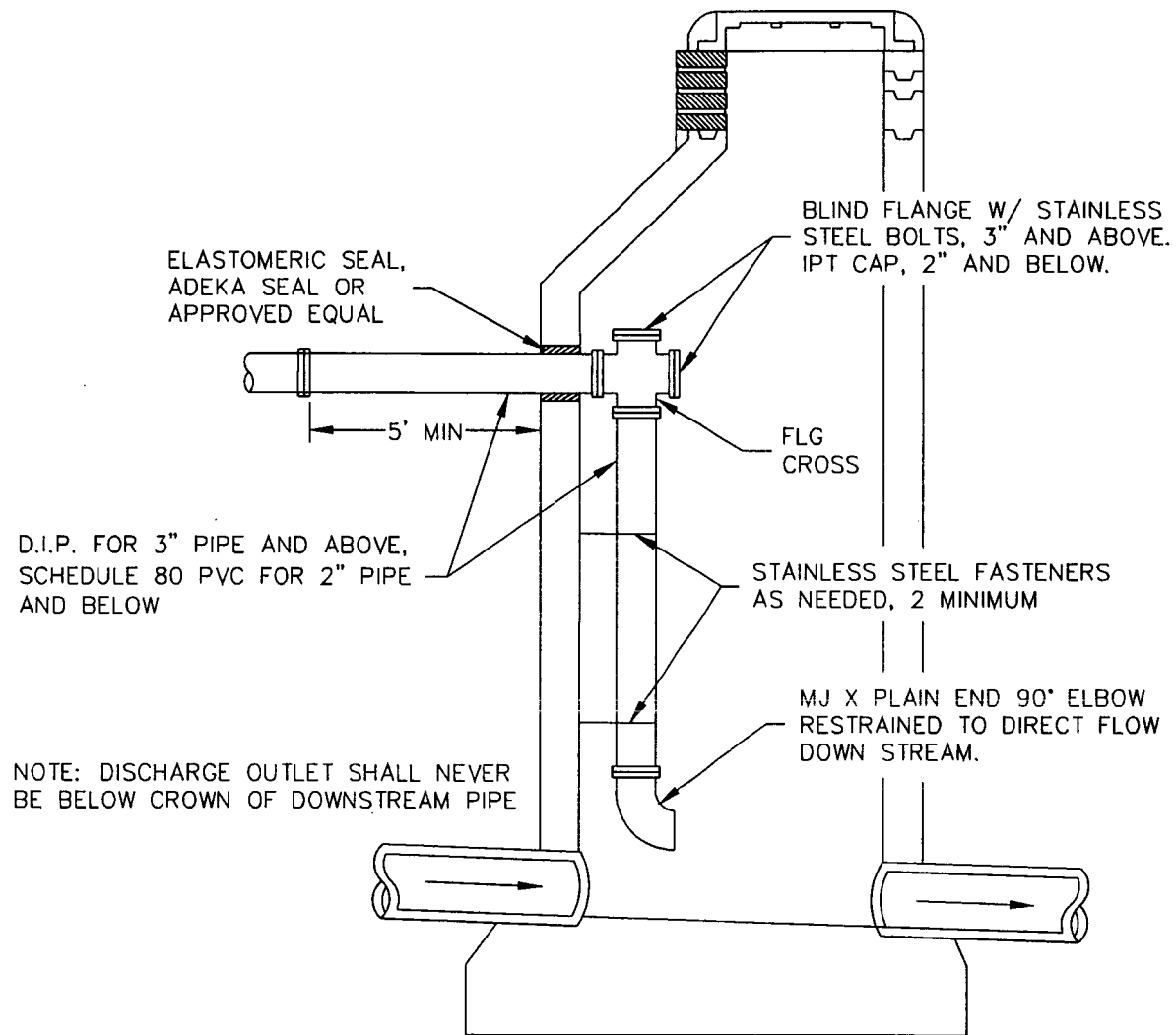

DETAIL NO.
2402

City of Scottsdale
Standard Details

APPROVED BY:
Scottsdale Standards &
Specifications Committee

FORCE MAIN DISCHARGE MANHOLE

DETAIL NO.
2402

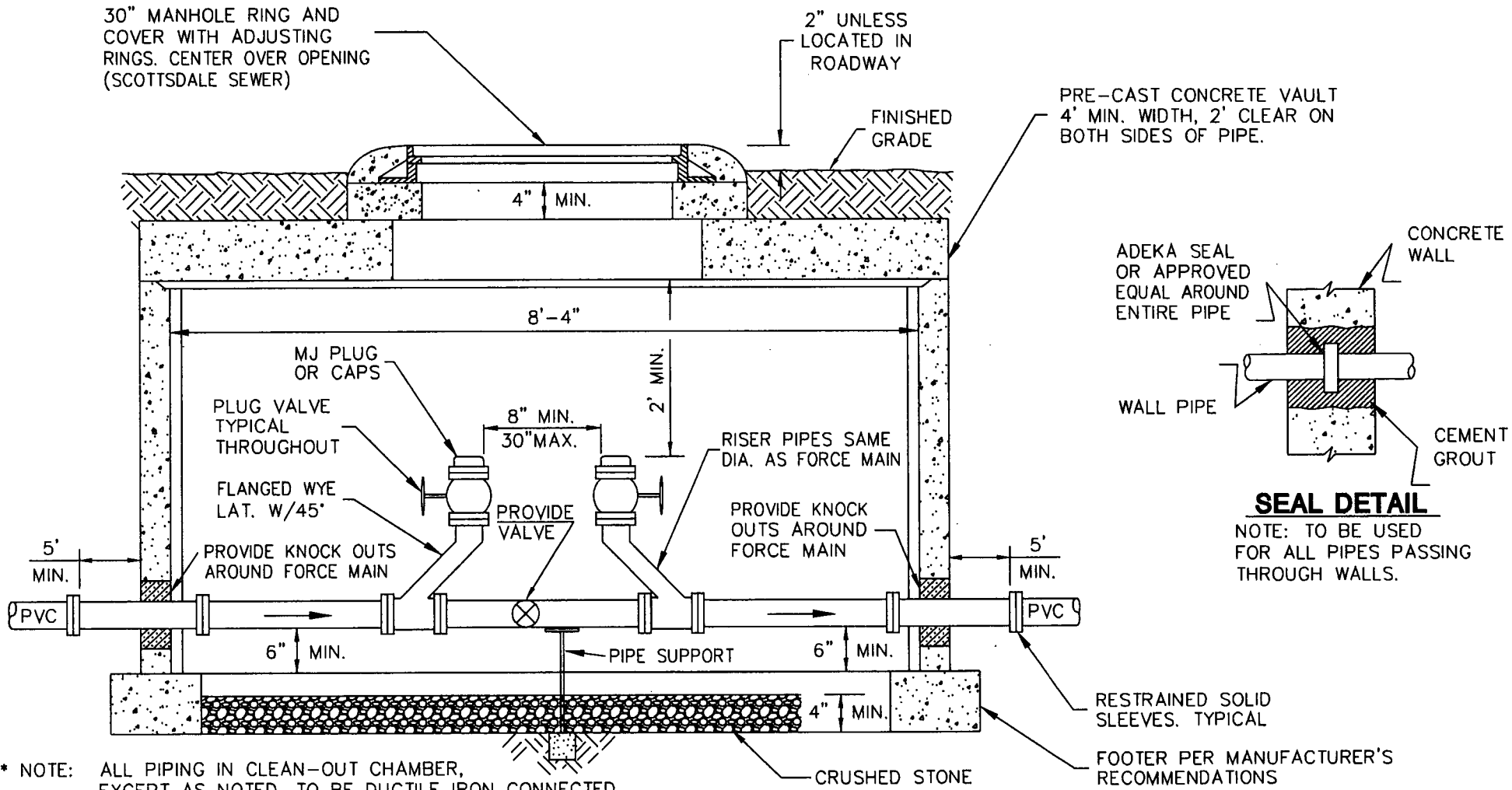

* NOTE: ALL PIPING IN CLEAN-OUT CHAMBER, EXCEPT AS NOTED, TO BE DUCTILE IRON CONNECTED WITH FLANGED JOINTS AND STAINLESS STEEL BOLTS.

SEAL DETAIL
 NOTE: TO BE USED FOR ALL PIPES PASSING THROUGH WALLS.

DETAIL NO. 2403	City of Scottsdale Standard Details	APPROVED BY: Scottsdale Standards & Specifications Committee	TWO-WAY FORCE MAIN CLEAN-OUT - 3' AND ABOVE	DETAIL NO. 2403
---------------------------	--	--	--	---------------------------

SEWAGE AIR RELEASE VALVE (APCO MODEL 400, 17 1/2" VALVE HEIGHT, OR APPROVED EQUAL) SUPPORT AIR RELEASE VALVE AS NEEDED

30" MANHOLE RING AND COVER WITH ADJUSTING RINGS. CENTER OVER OPENING. (SCOTTSDALE SEWER)

2" UNLESS LOCATED IN ROADWAY

PRE-CAST CONCRETE VAULT 4' MIN. WIDTH, 2' CLEAR ON BOTH SIDES OF PIPE.

FINISHED GRADE

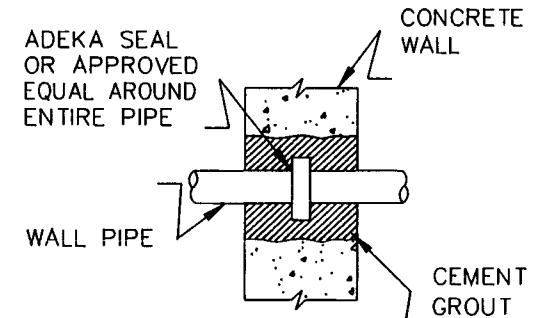
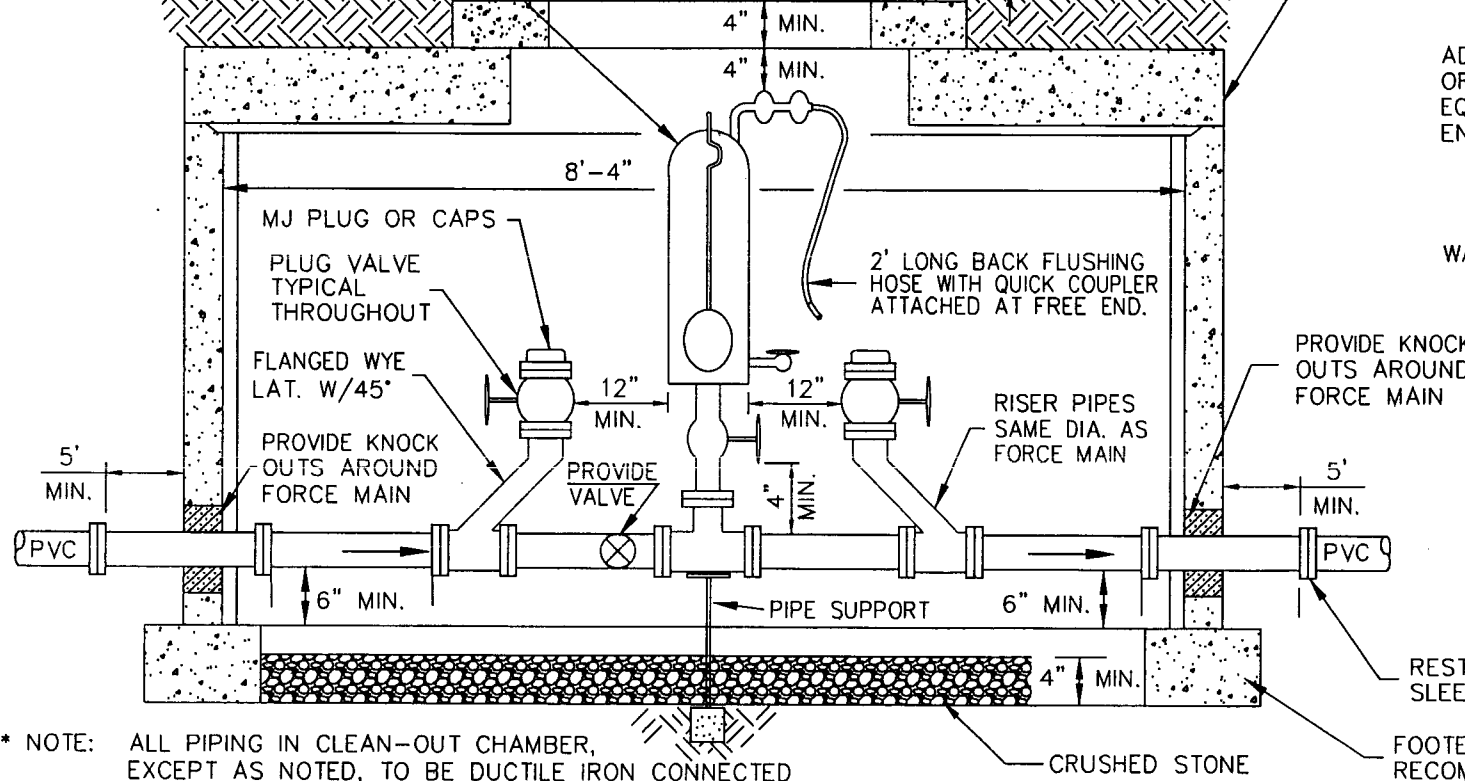

SEAL DETAIL

NOTE: TO BE USED FOR ALL PIPES PASSING THROUGH WALLS.

* NOTE: ALL PIPING IN CLEAN-OUT CHAMBER, EXCEPT AS NOTED, TO BE DUCTILE IRON CONNECTED WITH FLANGED JOINTS AND STAINLESS STEEL BOLTS.

DETAIL NO. 2404

City of Scottsdale
Standard Details

APPROVED BY:
Scottsdale Standards & Specifications Committee

FORCE MAIN CLEAN-OUT W/ SEWAGE AIR RELEASE VALVE

DETAIL NO. 2404

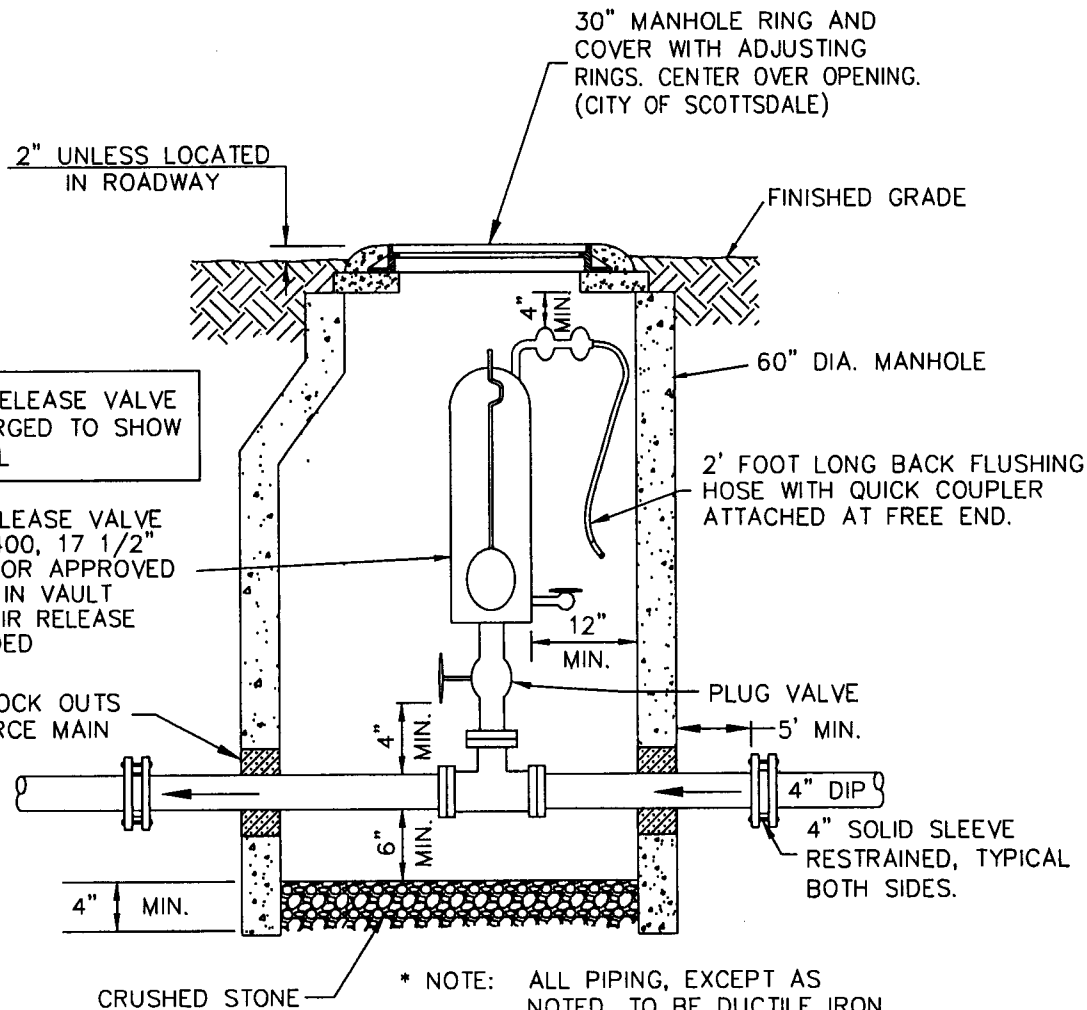

AIR RELEASE VALVE ENLARGED TO SHOW DETAIL

SEWAGE AIR RELEASE VALVE (APCO MODEL 400, 17 1/2" VALVE HEIGHT, OR APPROVED EQUAL) CENTER IN VAULT AND SUPPORT AIR RELEASE VALVE AS NEEDED

PROVIDE KNOCK OUTS AROUND FORCE MAIN

4" MIN.

* NOTE: ALL PIPING, EXCEPT AS NOTED, TO BE DUCTILE IRON WITH FLANGE JOINTS AND STAINLESS STEEL BOLTS.

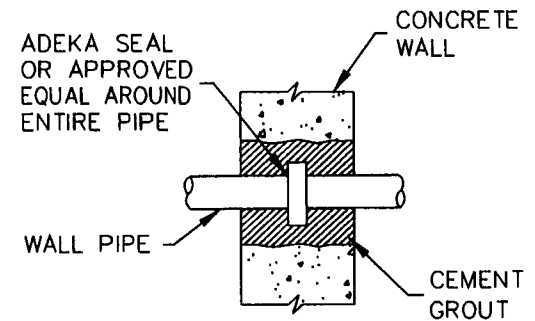

SEAL DETAIL

NOTE: TO BE USED FOR ALL PIPES PASSING THROUGH WALLS.

DETAIL NO. 2405

City of Scottsdale Standard Details

APPROVED BY: Scottsdale Standards & Specifications Committee

SEWER AIR RELEASE VALVE

DETAIL NO. 2405

BOLTDOWN, WATERTIGHT
MANHOLE RING & COVER
(SCOTTSDALE SEWER)

6" CLASS 'B' CONCRETE
ENCASEMENT FROM RING
& COVER TO TOP OF
MANHOLE CONE SECTION

CONCRETE SEWER MANHOLE
PER MAG STD DETAIL 420

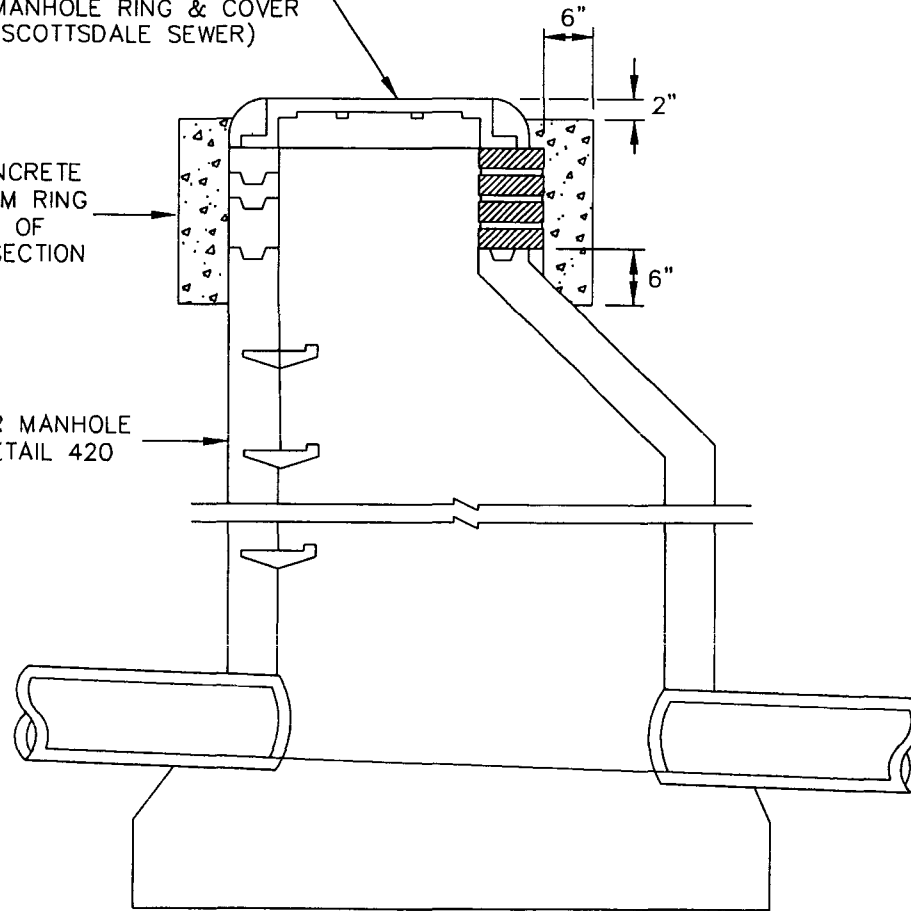

DETAIL NO.
2420

City of Scottsdale
Standard Details

APPROVED BY:
Scottsdale Standards &
Specifications Committee

WATER TIGHT CONCRETE SEWER MANHOLE

DETAIL NO.
2420

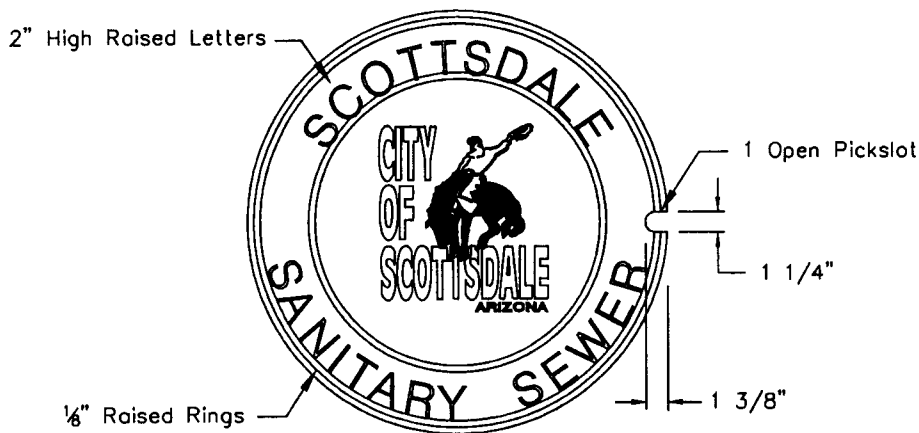

TOP VIEW

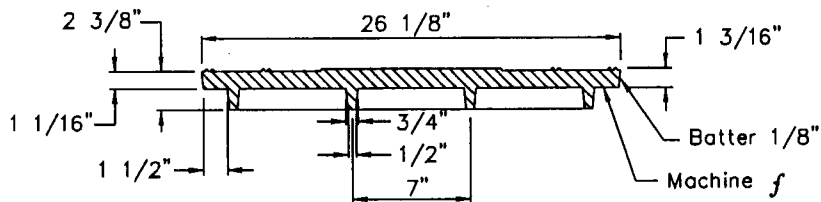

SECTION OF COVER

24" MANHOLE COVER

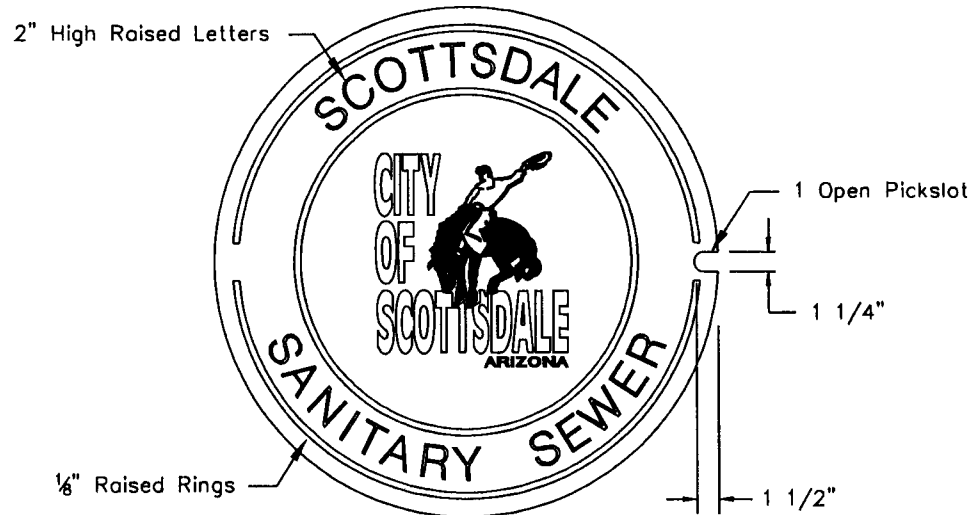

TOP VIEW

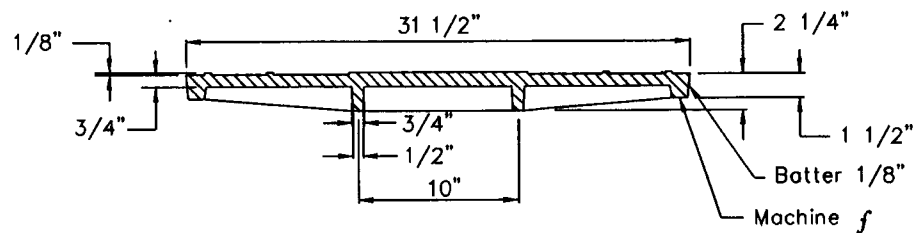

SECTION OF COVER

30" MANHOLE COVER

NOTES

1. Material: Cast Gray Iron ASTM A-48, Class 35B, Unpainted
2. The Total Width Of Individual Letters To Be Such That Letters And Words Are Equally Spaced And Balanced.
3. Letters To Be 2" In Height And Raised $\frac{1}{8}$ " Above Level Of Cover. Type Of Letters To Be Submitted For Approval.
4. Weight Of Castings Shall Be No More Than 2% Less Than Weight Specified. Castings Shall Conform To M.A.G. Section 787.

DETAIL NO.
2421

City of Scottsdale
Standard Details

APPROVED BY:
Scottsdale Standards & Specifications Committee

SANITARY SEWER MANHOLE COVER

DETAIL NO.
2421

REVISED 3/23/05

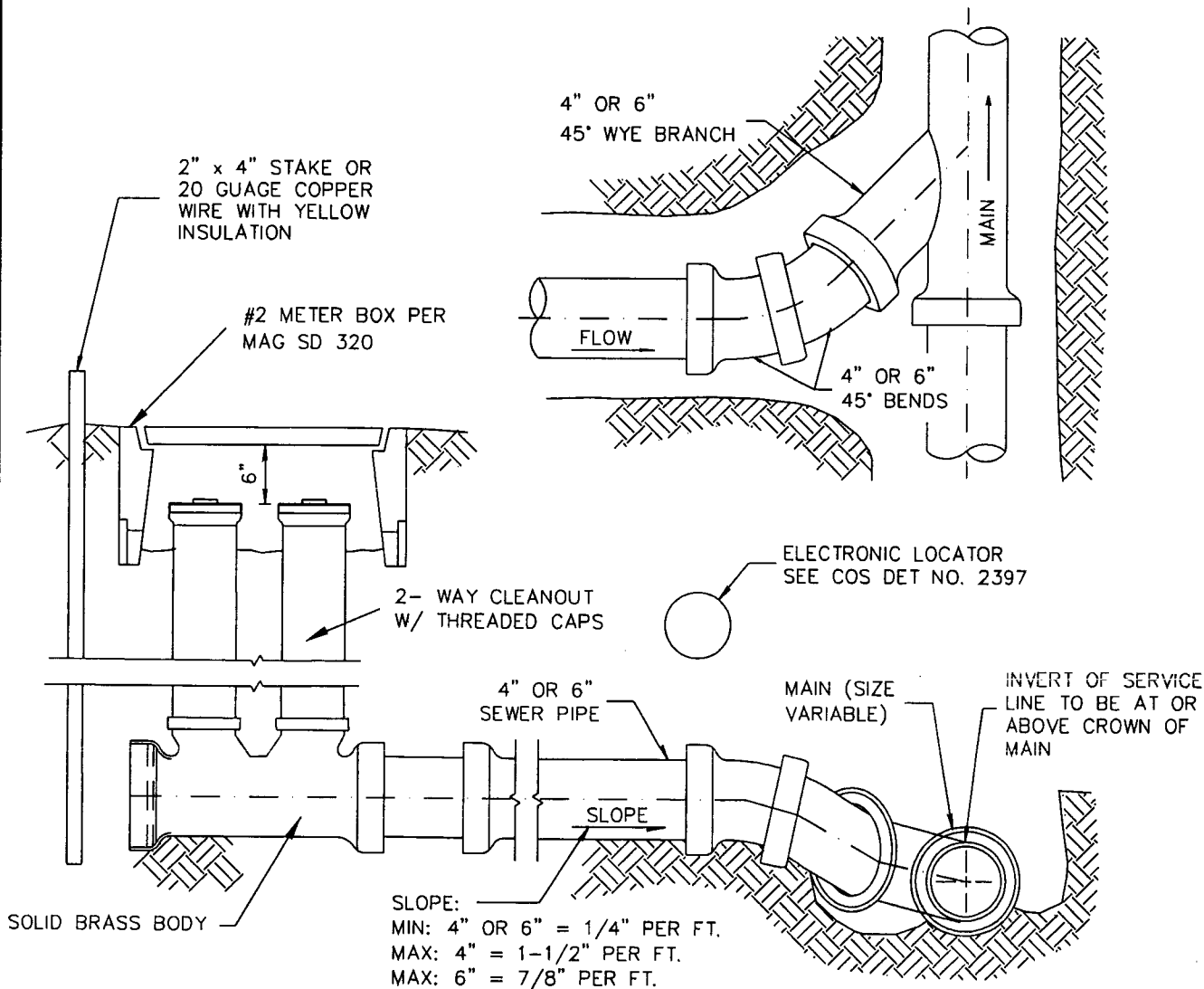

NOTES:

1. CONSTRUCTION DETAIL APPLIES WHERE CONTRACTOR BUILDS HOUSE CONNECTION. TAP EXTENDS TO PROPERTY LINE IN ALLEYS OR STREETS OR TO EASEMENT LINE.
2. SIZE OF TAP SHALL BE DESIGNATED ON PLANS.
3. CONSTRUCT TAP AT MINIMUM SLOPE IF COVER WILL BE LESS THAN 5' AT PROPERTY LINE.
4. IF DEPTH REQUIRES, MINIMUM SLOPE CAN BE REDUCED TO 1/8" PER FOOT PROVIDED STUB IS STAKED TO GRADE.
5. ALL FITTINGS SHALL BE INSTALLED IN ACCORDANCE WITH ASTM D-2321. THE CONTRACTOR MAY VARY FROM THE DRAWING TO USE THE APPROPRIATE WYES, TEE-WYES AND BENDS TO ENSURE NO MISALIGNMENT OF THE PIPE AND FITTINGS. BLOCK OR BRACE FITTING JOINTS TO ENSURE ZERO DEGREES ANGULAR JOINT DEFLECTION.
6. END OF TAP TO BE SEALED AND MARKED AS NOTED.
7. PROVIDE ELECTRONIC BALL MARKER PER COS STD DETAIL 2397.

DETAIL NO.
2440

City of Scottsdale
Standard Details

APPROVED BY:
Scottsdale Standards & Specifications Committee

SEWER BUILDING CONNECTION

DETAIL NO.
2440

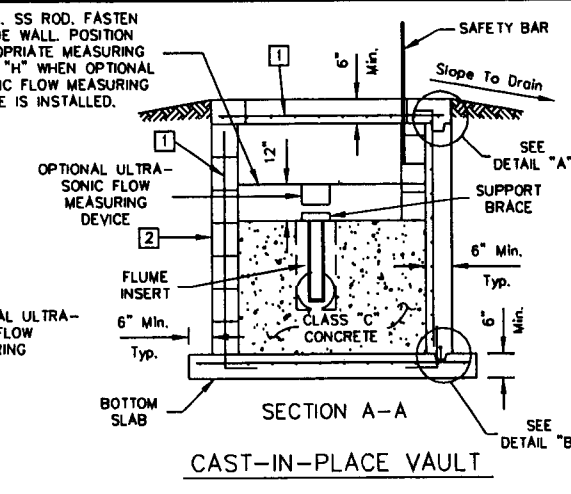
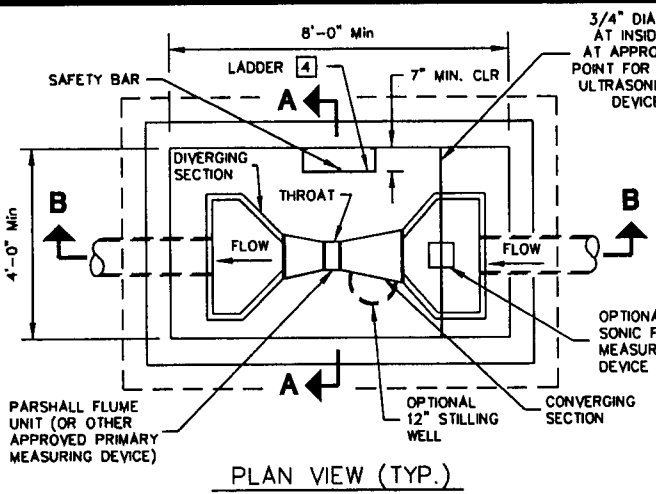
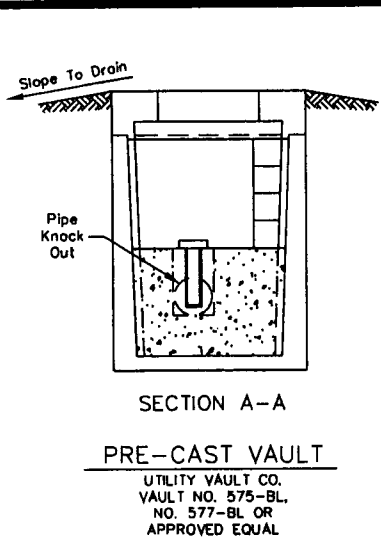

- NOTES:**
- 1 Reinforced steel and clearance as approved by the engineer.
 - 2 Block masonry may be used in lieu of CIP walls. 8" block masonry, grout each cell to full height (grout per MAG Section 776).
 - 3 2 Torsion spring assisted galvanized diamond plate access doors (design loading AASHO-H20) locking with type 304SS hardware and safety bar (Bitco Model LU-3, or approved equal).
 - 4 Ladder shall be furnished and installed in accordance with the detail and shall meet the requirements of OSHA for Type IA (300 lbs) fixed ladders, single section. Details of ladder construction, along with a certification that the ladder meets or exceeds OSHA requirements for Type IA (300 lbs) service shall be submitted for review prior to furnishing and installing. Mill finished aluminum ladder or approved corrosion resistant material.
 - 5 2"x 4" key, center on wall. (Install rope caulk continuously).
 - 6 1-5/8"x 2-1/2"x 3" key.
 - 7 4" PVC dumbbell type continuous waterstop 3/8" min. thickness. (Wash thoroughly prior to installation).
 - 8 Anchor straps (3 each side) with 5/8" x 3-1/2" 316SS anchor bolts with lock washer and nut.

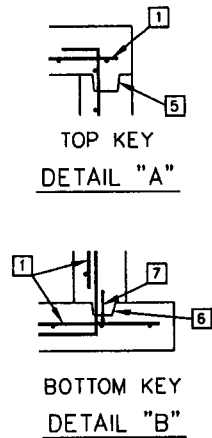
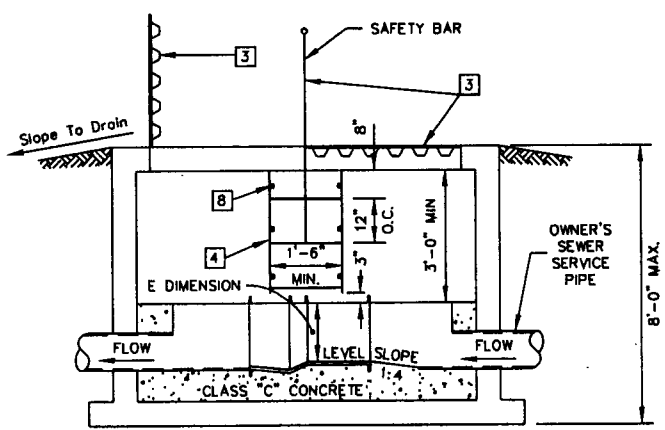
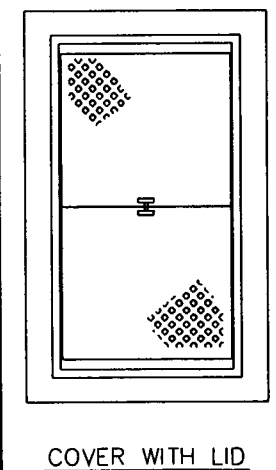

GENERAL NOTES

1. All construction shall conform to MAG Specifications and Details and City of Scottsdale Supplement to MAG Specifications and Details, unless modified on the plans.
2. All concrete floors, walls and top slab of the structure shall conform to MAG section 725, Class A, minimum compressive strength at 28 days = 3,000 psi.
3. All concrete for the grout fillet inside the structure shall conform to MAG Section 725, Class C, minimum compressive strength at 28 days = 2,000 psi.
4. All steel reinforcing shall be deformed bars, Grade 60, billet steel conforming to ASTM Specification No. A-615, latest edition.
5. The Monitoring/Sampling Vault shall be installed on the owner's property as close to the customer top to the City sewer as feasible, and approved by the City of Scottsdale.
6. Flume size should be based upon the minimum and maximum flow rates and velocities to insure free-flow conditions.
-Maximum Flow = 70%-100% of maximum capacity of selected flume size.
-0.5 inches of flow should exist at the minimum actual flow.
7. Flume floor elevation should be high enough, relative to downstream conditions, to prevent submerged flow (50% submergence is acceptable at maximum flow), install the flume level (longitudinally and transversely) in the converging section.
8. Upstream flow should be wave free, non-turbulent, and symmetrical having a uniform velocity (1fps minimum to 3 fps maximum) at least 10 times the diameter of the upstream sewer pipe in length in the approach channel. Bends upstream in the flume will NOT be allowed for a distance of 25 pipe diameters unless conditions in the approach section of the flume will not be adversely affected.
9. The flume shall be installed off-center and away from the ladder to allow the maximum working space for City personnel.
10. It shall be the owner's responsibility to properly maintain the flume in accordance with the manufacturers recommendations to ensure the accuracy of the measurement.

A Fisher and Porter type 10F1940, Hinde Engineering Company, PS-1001, or approved equal molded fiberglass reinforced polyester Parshall Flume shall be installed. The flume shall be molded in one piece with ample wall thickness and reinforcing ribs to prevent distortion during shipment, installation and operation. The flume shall be self-supporting and require no external supporting structure. Interior dimensions shall conform to those in the latest revision of Water Measurement Manual published by the U.S. Department of the Interior, Water and Power Resources Services. The throat width and flume height ("E dimension") shall be per plan.

REVISED 3/28/02

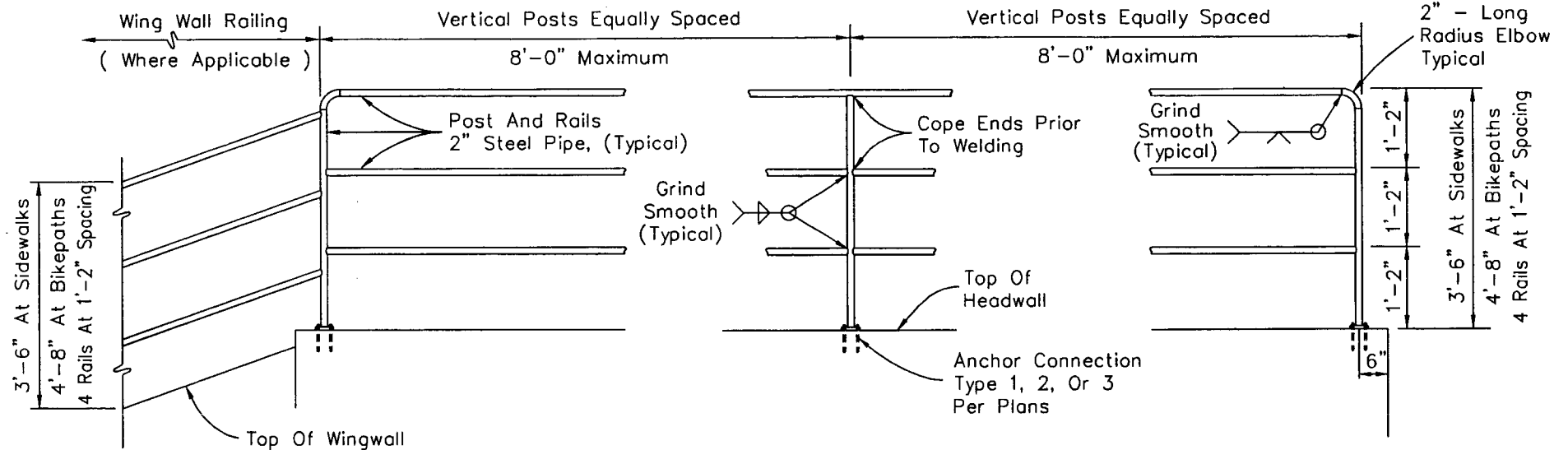

ELEVATION

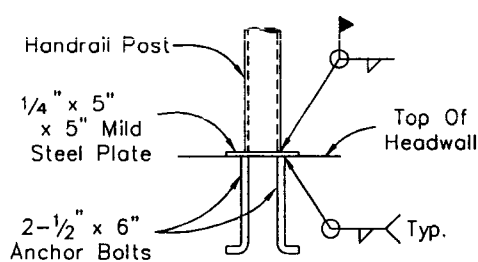

TYPE 1
ANCHOR PLATE DETAIL

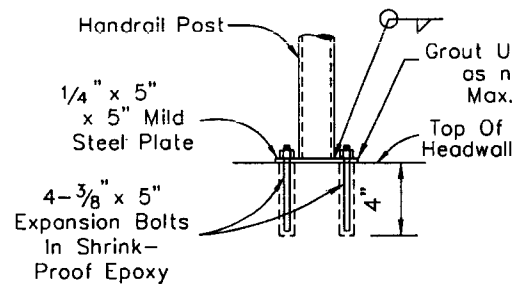

TYPE 2
EXPANSION BOLT DETAIL

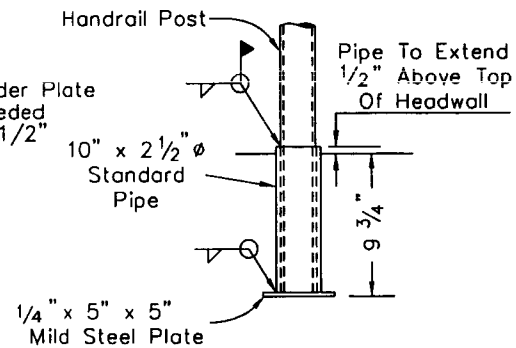

TYPE 3
PIPE SLEEVE DETAIL

CONSTRUCTION NOTES

1. Paint handrail per MAG Specifications Section 530. Color per plans.
2. Vertical posts to be evenly spaced.

DETAIL NO.
2508

**City of Scottsdale
Standard Details**

APPROVED BY:
**Scottsdale Standards &
Specifications Committee**

HANDRAIL DETAIL

DETAIL NO.
2508

REVISED 2/27/01

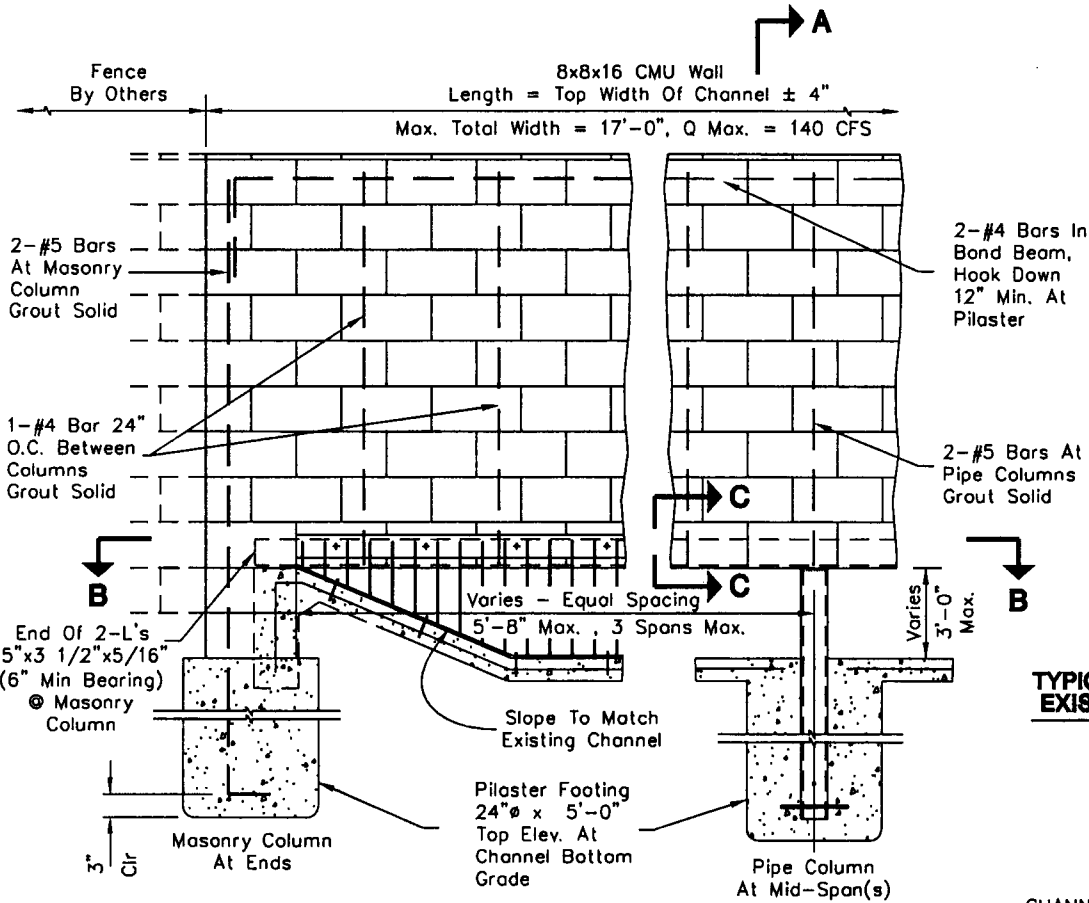

ELEVATION

WALL NOTES:

1. Wall Height, Finish Texture And Color to Match Adjacent Property Wall.
2. Construction To Conform to MAG Section 510.
3. Trash Rack Grate Required on Private Lots only; And Property Owner Shall Be Responsible for Cleaning.

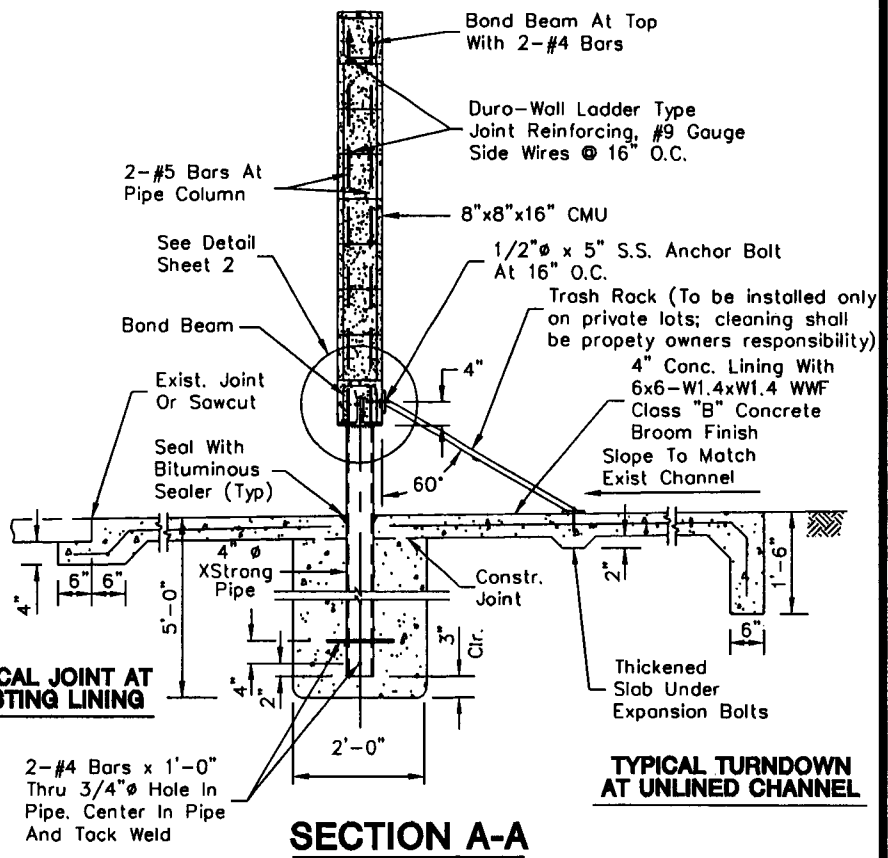

SECTION A-A

CHANNEL NOTES:

- UNLINED CHANNELS: Construct New Lining 6' Minimum Upstream And Downstream From Wall With Turndown At All Edges Of Lining.
- EXISTING LINED CHANNELS: Remove Existing Lining 4' Minimum Upstream And Downstream From Wall. Replace Using Joint Shown.

DETAIL NO.
2515-1

**City of Scottsdale
Standard Details**

APPROVED BY:
**Scottsdale Standards &
Specifications Committee**

WALL OPENING & EROSION PROTECTION - TYPE 1

SHEET 1 OF 2
DETAIL NO.
2515-1

Top Stone:
Loose Naturally Placed
Native Stone. $D_{50} = 8"$
(Size: 3" Min. - 12" Max.)

Note: Stone shall
be fractured with
angular faces; no
river run

Bed Stone:
Hand Placed Native Stone
 $D_{50} = 15"$ (Size: 12" Min. -
18" Max.)

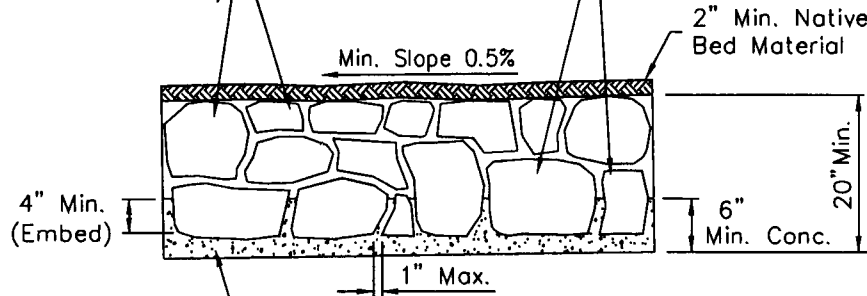

Integrally Colored Concrete Or
Grout, Color To Be Determined By
Plans or City Of Scottsdale Inspector
(Color to match native stone)

TYPE 1 - BURIED GROUDED RIP-RAP DETAIL

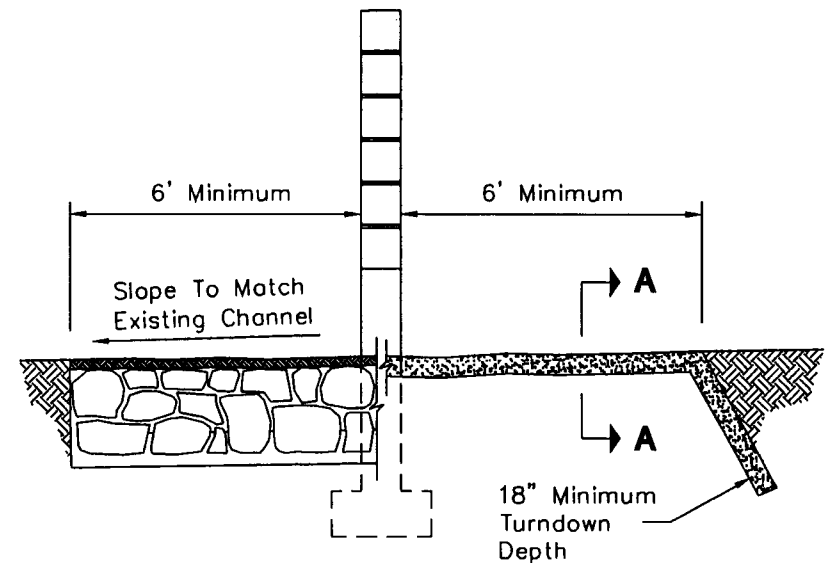

SECTION AT WALL

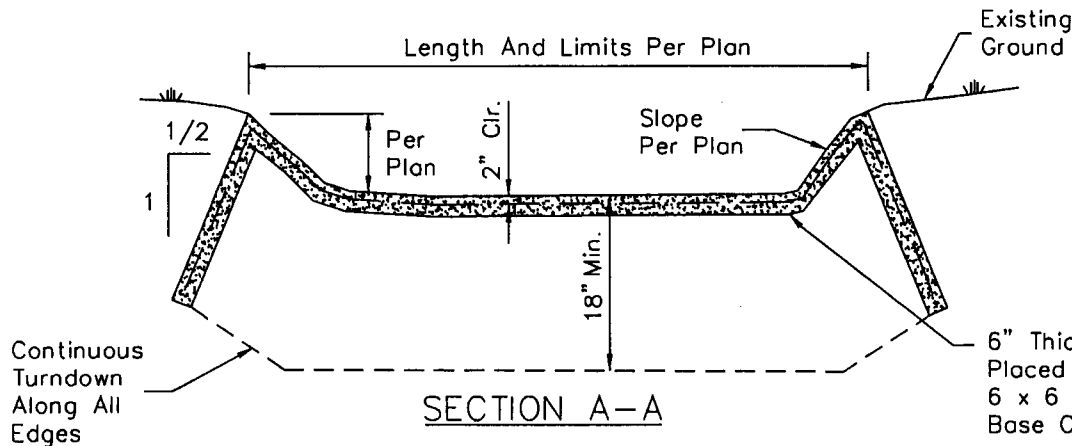

SECTION A-A

TYPE 2- PNEUMATICALLY PLACED MOTAR DETAIL

DETAIL NO.
2515-3

City of Scottsdale
Standard Details

APPROVED BY:
**Scottsdale Standards &
Specifications Committee**

WALL OPENING EROSION PROTECTION

DETAIL NO.
2515-3



TOP VIEW

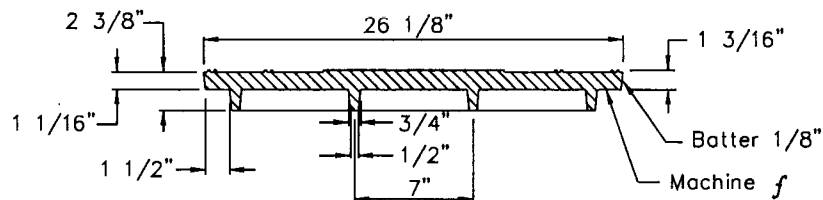

SECTION OF COVER

24" MANHOLE COVER

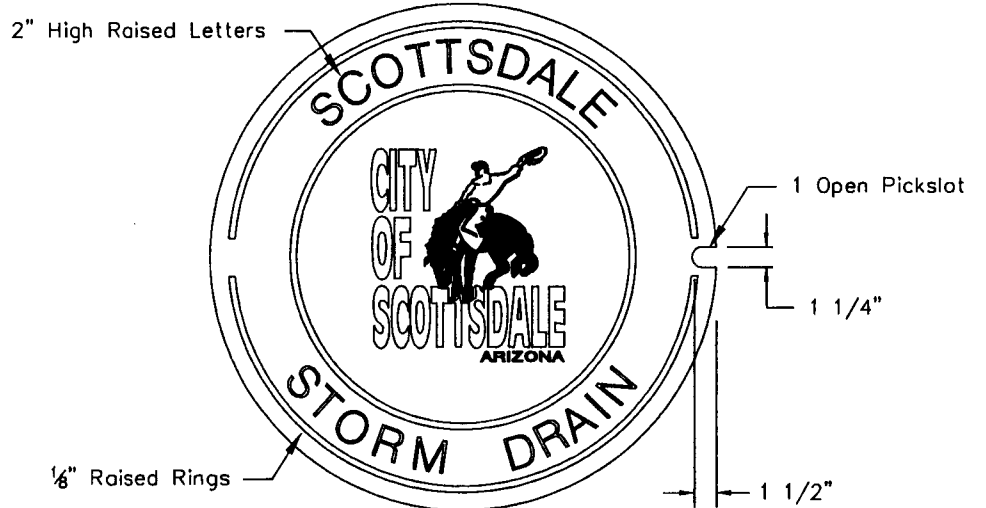

TOP VIEW

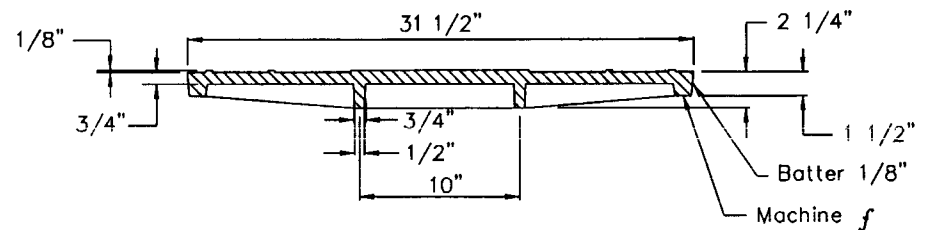

SECTION OF COVER

30" MANHOLE COVER

NOTES

1. Material: Cast Gray Iron ASTM A-48, Class 35B, Unpainted
2. The Total Width Of Individual Letters To Be Such That Letters And Words Are Equally Spaced And Balanced.
3. Letters To Be 2" In Height And Raised $\frac{1}{8}$ " Above Level Of Cover. Type Of Letters To Be Submitted For Approval.
4. Weight Of Castings Shall Be No More Than 2% Less Than Weight Specified. Castings Shall Conform To M.A.G. Section 787.

DETAIL NO. 2520	City of Scottsdale Standard Details	APPROVED BY: Scottsdale Standards & Specifications Committee	STORM DRAIN MANHOLE COVER	DETAIL NO. 2520
---------------------------	--	--	----------------------------------	---------------------------

REVISED 6/19/95

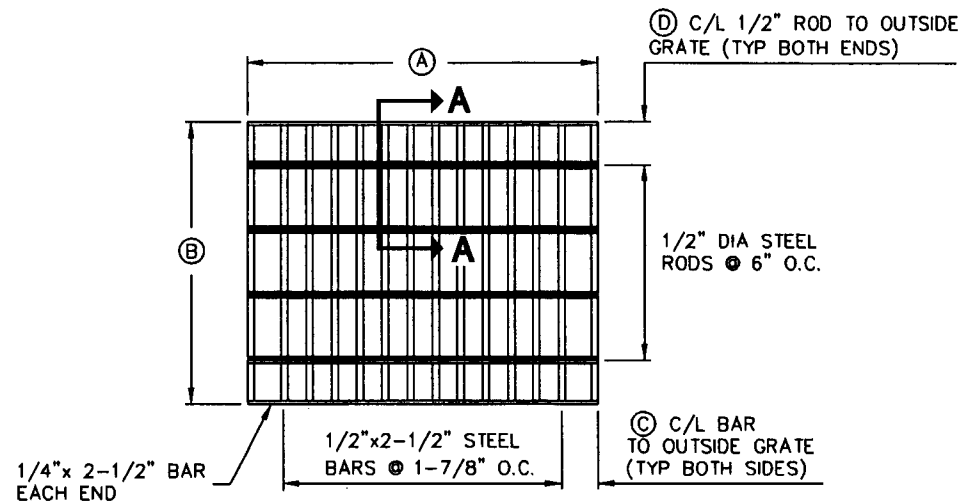
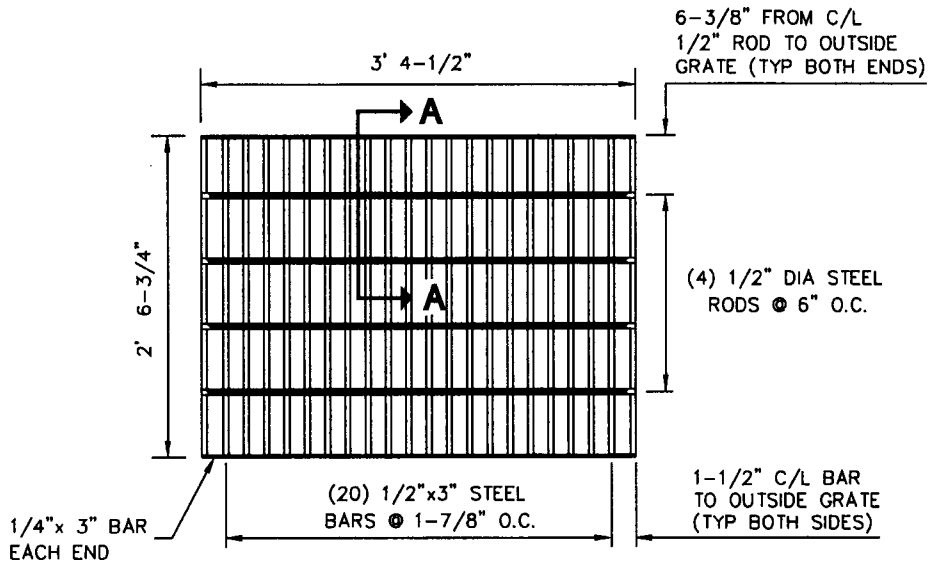

GRATE FOR TYPE "F" CATCH BASIN
REPLACES GRATE SHOWN IN MAG DETAIL NO 535

GRATE FOR TYPE "G" CATCH BASIN
REPLACES GRATE SHOWN IN MAG DETAIL 537

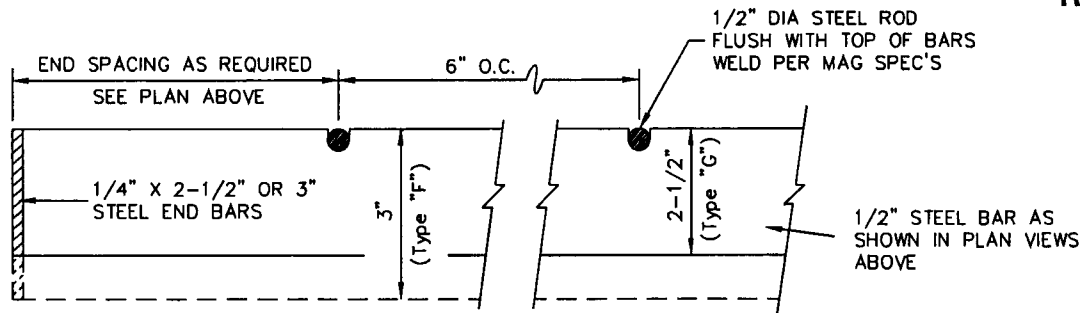

SECTION A-A

NOTES:

1. ALL MATERIALS AND FABRICATION TO BE AS SPECIFIED IN MAG STANDARD DETAIL NO. 540-2

TYPE "G" GRATE DIMENSIONS		
	SINGLE GRATE	DOUBLE GRATE
①	2'-2"	4'-3 1/2"
②	2'-2"	2'-2"
③	2'-11/16"	2'-5/16"
④	0'-4"	0'-3 3/4"

DETAIL NO.
2535

**City of Scottsdale
Standard Details**

APPROVED BY:
**Scottsdale Standards &
Specifications Committee**

CATCH BASIN GRATES

DETAIL NO.
2535

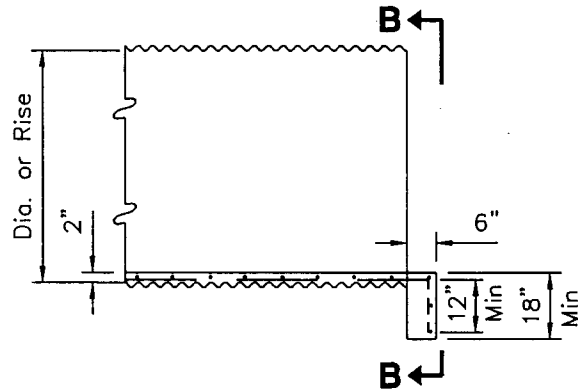

NO HEADWALL

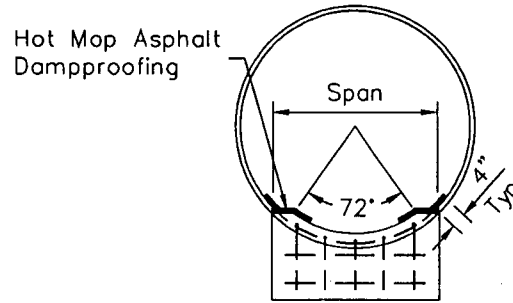

ELEVATION B-B

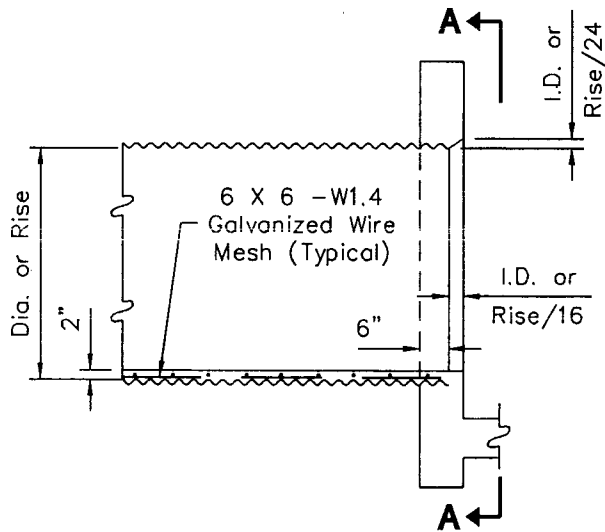

WITH HEADWALL

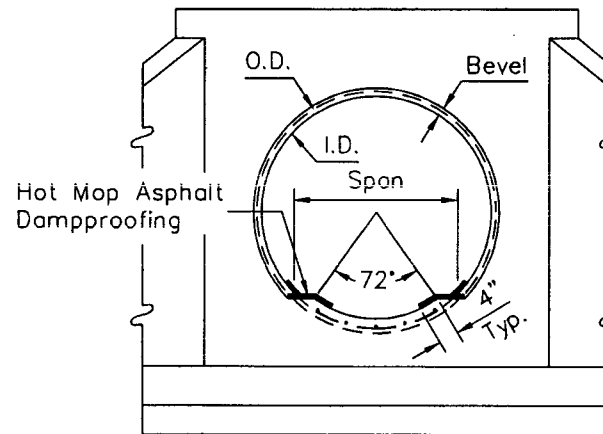

ELEVATION A-A

GENERAL NOTES

1. For lateral dimensions of invert paving, use 72° control for CMP and span for CMPA.
2. Paving shall be scored at 18" min. (transverse) along pipe length.
3. Use bevel on inlet headwall only.
4. Wire mesh shall be tack welded to corrugation crests at 18" intervals. Laps shall be 6" min.
5. Paving shall not be placed until backfilling is completed.
6. Concrete shall be Class "B".

DETAIL NO.
2554

**City of Scottsdale
Standard Details**

APPROVED BY:
**Scottsdale Standards &
Specifications Committee**

**CONCRETE INVERT PAVING FOR
CORRUGATED METAL PIPE AND PIPE ARCH**

DETAIL NO.
2554

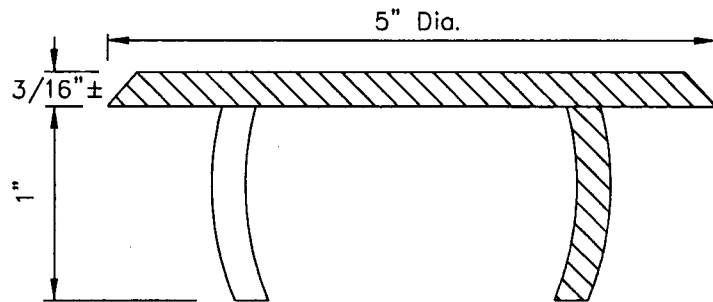

TYPE "A"

TO BE INSTALLED IN WET CONCRETE
DURING CONSTRUCTION

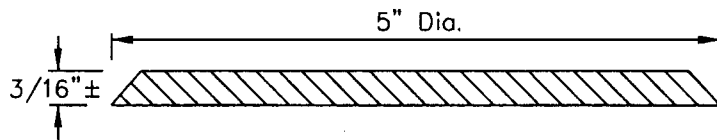

TYPE "B"

TO BE INSTALLED WITH ADHESIVE
ON EXISTING STRUCTURES



NOTES

1. Material: Cast Aluminum
2. The Total Width Of Individual Letters To Be Such That Letters And Words Are Equally Spaced And Balanced.
3. Letters To Be 1/2" In Height. Type Of Letters To Be Submitted For Approval.

DETAIL NO. **2560-1** **City of Scottsdale**
Standard Details

APPROVED BY:
Scottsdale Standards & Specifications Committee

STORM DRAIN INLET MARKER

DETAIL NO. **2560-1**

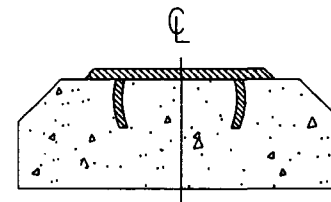
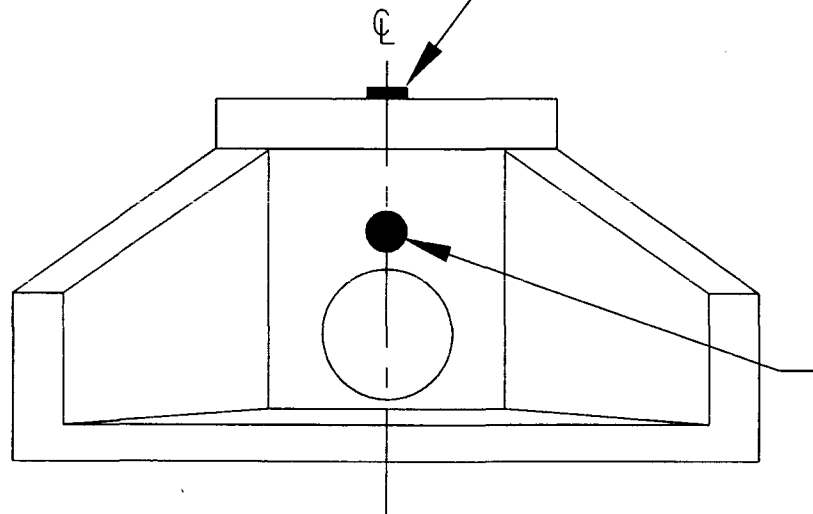
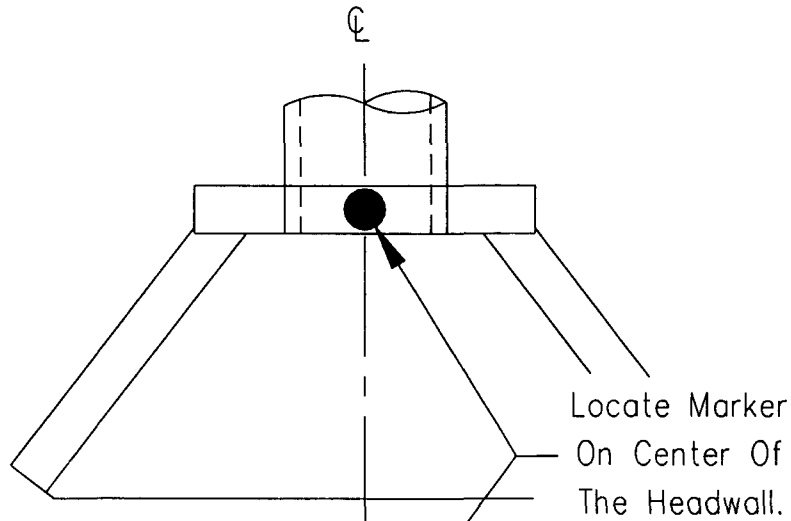

TYPE "A"
TO BE INSTALLED IN WET CONCRETE
DURING CONSTRUCTION

Dynamix #6125-1
Urethane Universal
Adhesive

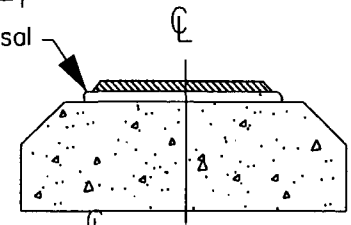

TYPE "B"
TO BE INSTALLED WITH ADHESIVE
ON EXISTING STRUCTURES

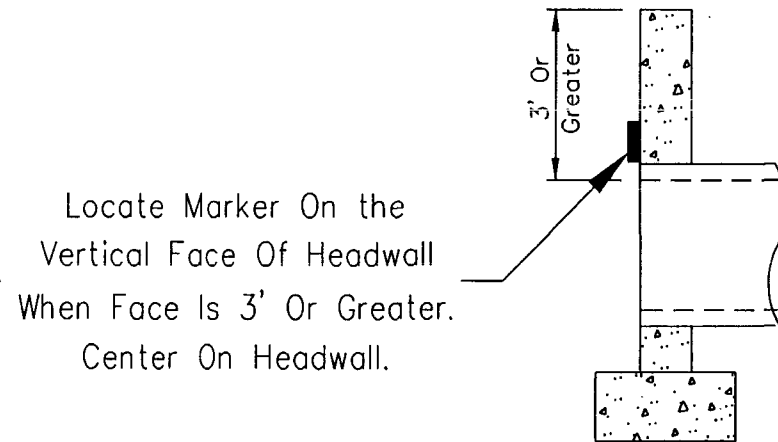

DETAIL NO.
2560-2

**City of Scottsdale
Standard Details**

APPROVED BY:
**Scottsdale Standards &
Specifications Committee**

STORM DRAIN INLET MARKER ON HEADWALL

DETAIL NO.
2560-2

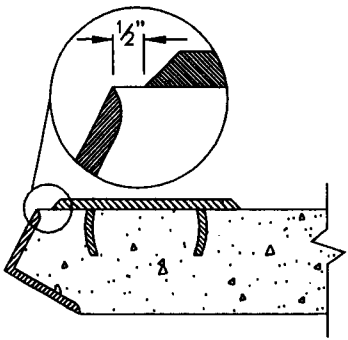
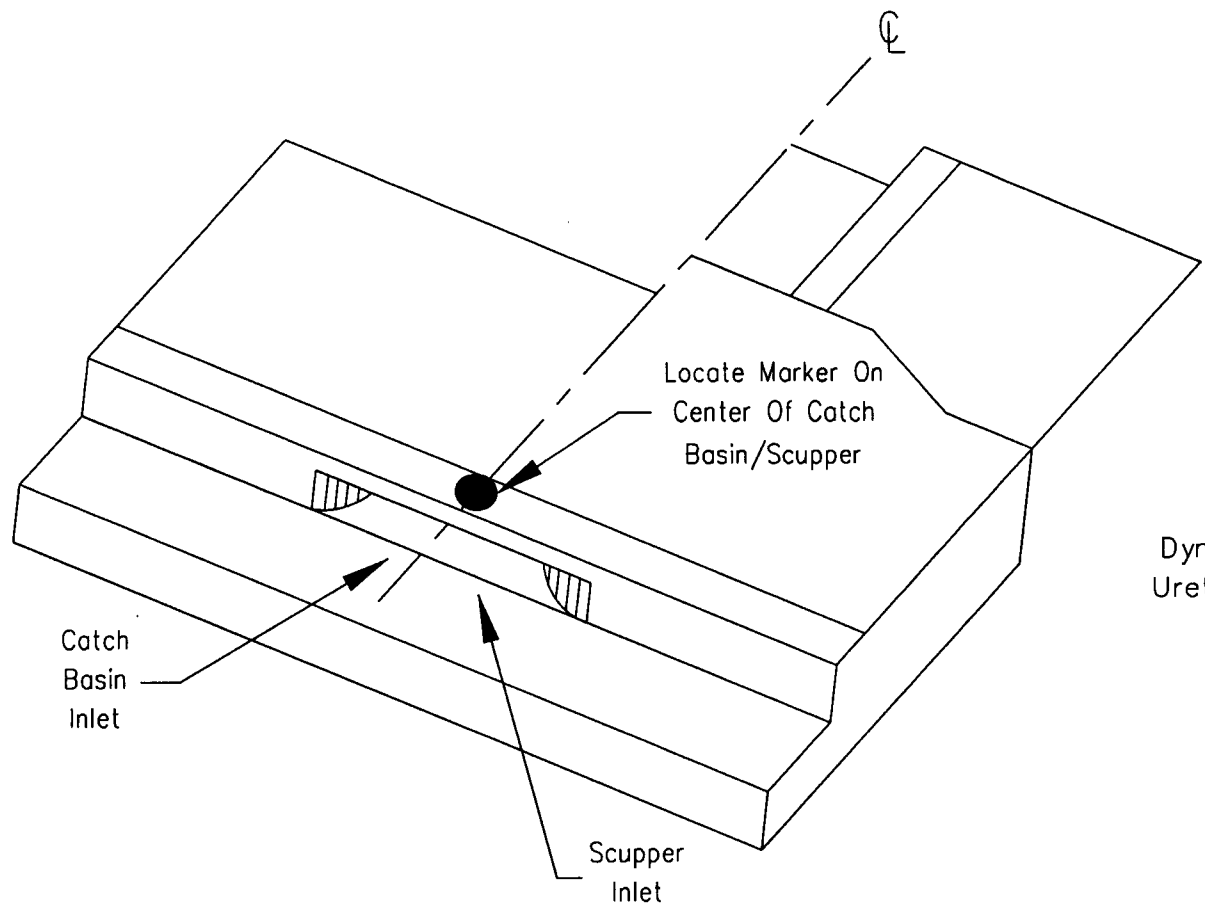

TYPE "A"

TO BE INSTALLED IN WET CONCRETE DURING CONSTRUCTION

Dynamix #6125-1 Urethane Universal Adhesive

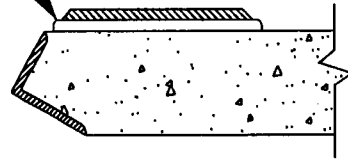

TYPE "B"

TO BE INSTALLED WITH ADHESIVE ON EXISTING STRUCTURES

DETAIL NO.
2560-3

**City of Scottsdale
Standard Details**

APPROVED BY:
**Scottsdale Standards &
Specifications Committee**

STORM DRAIN INLET MARKER ON CATCH BASIN/SCUPPER

DETAIL NO.
2560-3

REVISED 3/28/02

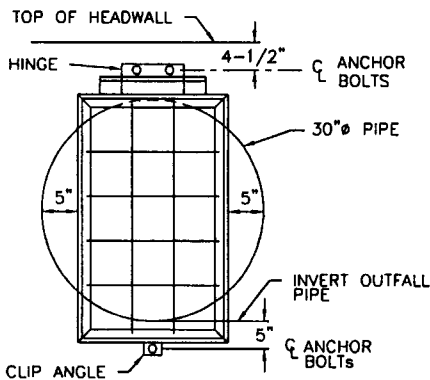

30"Ø & 36"Ø PIPES ONLY, SINGLE HINGE & CLIP ANGLE DETAIL

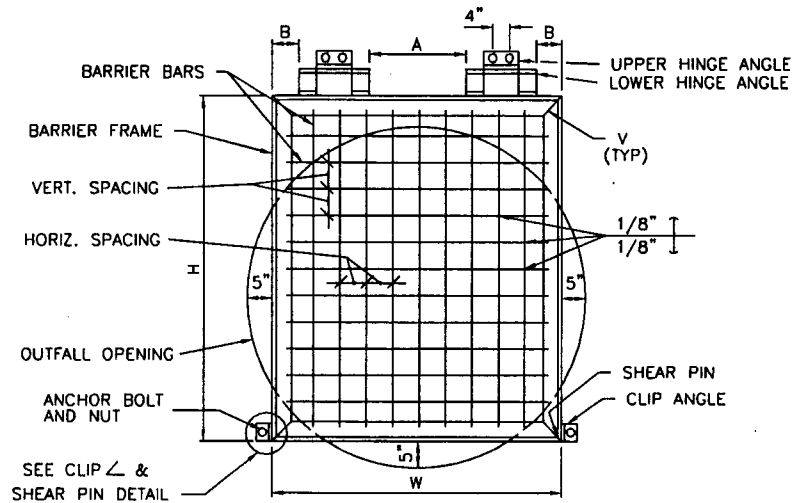

TYPICAL BARRIER DETAIL

HINGE PIN

BOLT STOCK, THREAD BOTH ENDS SO NUT & LOCK WASHER ARE FLUSH WITH LOWER ∟, UPSET OR DAMAGE EXPOSED THREADS. COAT PIN WITH WATERPROOF GREASE BEFORE INSTALLATION.

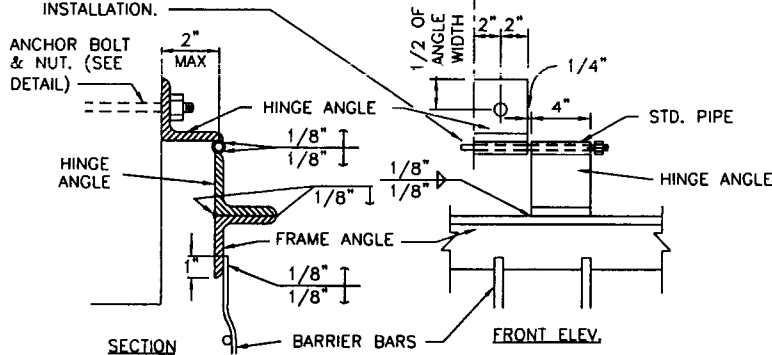

HINGE INSTALLATION DETAIL

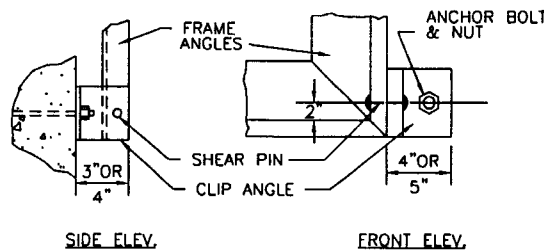

CLIP ANGLE & SHEAR PIN DETAIL

NOTES:

1. ALL SHEAR PIN ANGLES SHALL FIT SNUGLY AND TRULY FACE TO FACE. COVER WITH WATERPROOF GREASE PRIOR TO INSTALLATION OF PIN.
2. GALVANIZE ALL FERROUS PARTS AFTER FABRICATION.
3. THE SHEAR PIN HOLES IN THE ANGLE SHALL BE DRILLED FOR A TIGHT FIT OF THE SHEAR PINS.
4. FRAME AND HINGE ANGLES SHALL HAVE THE OUTSTANDING LEGS OUT FOR OUTLETS.
5. ALL ANCHOR BOLTS SHALL BE 5/8"Ø ANCHOR BOLTS EMBEDDED 4"(MIN.) INTO EPOXY GROUT.
6. ALL SHEAR PINS ARE TO BE PEENED BOTH ENDS AFTER INSTALLATION.
7. SHEAR PIN MATERIAL SHALL BE COMMERCIALY PURE ALUMINUM WIRE.
8. SEE BARRIER SHEDULE, DET. 2562-2 FOR VARIABLE DIMENSIONS.
9. COVER ALL MOVABLE CONTACT SURFACE WITH A COAT OF WATERPROOF GREASE PRIOR TO INSTALLATION.
10. ALL BARRIER BARS TO BE 1/2" PLAIN.

FILL WITH EPOXY GROUT ALL AROUND.

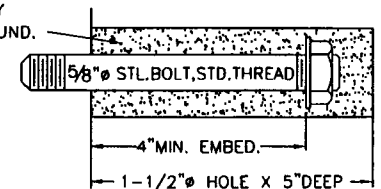

ANCHOR BOLT DETAIL

DETAIL NO. **2562-1** City of Scottsdale Standard Details

APPROVED BY: **Scottsdale Standards & Specifications Committee**

STORM SEWER OUTFALL ACCESS BARRIER 2562-1

DETAIL NO.

REVISED: 3/28/02

SIZE OF OUTFALL CONDUIT	FRAME ANGLES	SHEAR PIN CLIP ANGLES	SHEAR PINS	HINGE PINS	HINGE ANGLES	HINGE STD. PIPE	* NO. OF EQUAL BARRIER BAR SPACES (HORIZ.)	NO. OF EQUAL BARRIER BAR SPACES (VERT.)	H (OUT TO OUT FRAME ANGLES)	* W (OUT TO OUT FRAME ANGLES)	A	B
30"	2X2X1/4	4X4X1/4	1-1/8 ϕ	1/2" ϕ	2X2X1/4	3/4"	3	5	34"	20"	SINGLE HINGE CENTERED	
36"	2X2X1/4	4X4X1/4	1-1/8 ϕ	3/4" ϕ	2-1/2X 2-1/2X1/4	1"	4	6	40"	26"	SINGLE HINGE CENTERED	
42"	2X2X1/4	4X4X1/4	2-1/8 ϕ	1/2" ϕ	2X2X1/4	3/4"	5	6	42"	32"	0	0
48"	3X3X7/16	5X3X1/4	2-1/8 ϕ	3/4" ϕ	2-1/2X 2-1/2X1/4	1"	5	7	47"	38"	3"	1"
54"	3X3X7/16	5X3X1/4	2-1/8 ϕ	3/4" ϕ	2-1/2X 2-1/2X1/4	1"	6	8	54"	44"	5"	3"
60"	3X3X7/16	5X3X1/4	2-1/8 ϕ	3/4" ϕ	2-1/2X 2-1/2X1/4	1"	7	9	60"	50"	9"	4"
66"	3X3X7/16	5X3X1/4	2-1/8 ϕ	3/4" ϕ	2-1/2X 2-1/2X1/4	1"	8	10	66"	56"	11"	6"
72"	4X4X5/8	5X3X1/4	2-3/16 ϕ	1" ϕ	3X3X3/8	1-1/4"	9	11	73"	62"	15"	7"
78"	4X4X5/8	5X3X1/4	2-3/16 ϕ	1" ϕ	3X3X3/8	1-1/4"	10	11	79"	68"	17"	9"
84"	4X4X5/8	5X3X1/4	2-3/16 ϕ	1" ϕ	3X3X3/8	1-1/4"	11	13	86"	74"	21"	10"
90"	4X4X5/8	5X3X1/4	2-3/16 ϕ	1" ϕ	3X3X3/8	1-1/4"	12	13	92"	80"	23"	12"
96"	4X4X5/8	5X3X1/4	2-3/16 ϕ	1" ϕ	3X3X3/8	1-1/4"	12	14	98"	86"	29"	12"

*NOTE: Adjust these values for skewed conduits. Provide 5" maximum opening at each side and between bars.

DETAIL NO.
2562-2

**City of Scottsdale
Standard Details**

APPROVED BY:
**Scottsdale Standards &
Specifications Committee**

BARRIER SPECIFICATIONS SCHEDULE

DETAIL NO.
2562-2

Name	Size	Height	Width	Caliper	Name	Size	Height	Width	Caliper	Name	Size	Height	Width	Caliper	Name	Size	Height	Width	Caliper	Name	Size	Height	Width	Caliper	
ACACIA					ACACIA (Cont.)					ARGENTINE MESQUITE	15	5	3	0.75	VELVET ARIZONA (M)	15	5.5	3	0.5	SONORAN	15	6	2	0.75	
BLUE LEAF WATTLE (ACACIA SALIGNA)	15	6	2	0.75	WEEPING (ACACIA PENDULA)	15	5	2	0.75	(M) (PROSOPIS ALBA)	24	8	5	1.25	(PROSOPIS VELUNTINA)	24	7	4	1	(CERCIDIUM PRAECOX)	24	7	4	1.5	
	24	8	4	1.5		24	6.5	3	1.25		30	9	7	1.5		30	9	6	1.5		30	8	6	2	
	30	10	5	2		30	9	5	2		36	11	9	2		36	10	8	2		36	10	8	2.5	
	36	12	6	2.5		36	11	6	2.5		42	13	11	2.5		42	12	10	2.5		42	11	10	3	
BERLANDIERI GUAJILLO (M) (ACACIA BERLANDIERI)	15	4	2	0.5	WILLOW AUSTRALIAN WILLOW (ACACIA SALICINA)	15	6	2	0.75	MESQUITE (Cont.)					PALOVERDE					SONORAN (M)	15	5	2	0.5	
	24	5	4	1		24	8	4	1.5	CHILEAN MESQUITE (PROSOPIS CHILENSIS)	15	6	2	0.75	BLUE PALO VERDE (CERCIDIUM FLORIDUM)	15	6	2	0.75	(CERCIDIUM PRAECOX)	24	7	4	1	
	30	7	5	1.5		30	10	5	2		24	8	4	1.5		24	7.5	4	1.5		30	8	6	1.5	
	36	9	6	2		36	14	6	2.5		30	9	6	2		30	9	7	2		36	10	8	2	
MULGA (ACACIA ANEURA)	15	5	2	0.75	IRONWOOD DESERT IRONWOOD (OLNEYA TESOTA)																				
	24	7	4	1.5		15	3	2	0.5		36	10	8	2.5		36	10	8	2.5		42	11	10	2.5	
	30	9	6	2		24	6	3	1.25		42	12	10	3		42	12	9	3		48	12	12	3	
	36	10	8	2.5		30	8	6	2		48	14	12	3.5		48	14	10	3.5		OTHER TREES				
SHOESTRING (ACACIA STENOPHYLLA)	15	7	2.5	0.75		36	10	8	2.5	CHILEAN MESQUITE (M) (PROSOPIS CHILENSIS)	15	5	3	0.5	BLUE PALO VERDE (M) (CERCIDIUM FLORIDUM)	15	5	3	0.5	AFRICAN SUMAC (RHUS LANCEA)	15	7	2	0.75	
	24	9	4	1.5		42	11	9	3		24	8	5	1		24	7	4	1		24	9	4	1.25	
	30	11	5	2		48	12	10	3.5		30	9	7	1.5		30	8	6	1.5		30	11	6	2	
	36	13	6	2.5							36	10	9	2		36	10	8	2		36	12	8	2.5	
	42	15	7	3	DESERT IRONWOOD (M) (OLNEYA TESOTA)	15	3	2	0.5		42	12	11	2.5		42	12	9	2.5		42	14	8	3.5	
	48	17	8	4		24	6	3	1.25		48	14	13	3		48	14	11	3		48	15	9	4	
SHOESTRING (M) (ACACIA STENOPHYLLA)	15	7	2.5	0.5		30	8	6	2	HONEY MESQUITE (M) (PROSOPIS - GLANDULOSA)	15	6	2	0.75	LITTLE LEAF FOOTHILLS (CERCIDIUM - MICROPHYLLUM)	15	4	2	0.5	AFRICAN SUMAC (M) (RHUS LANCEA)	15	5	3	0.75	
	24	9	4	1		36	10	8	2.5		24	8	4	1.5		24	6	3	1		24	8	4.5	1	
	36	13	6	2		42	11	9	3		30	9	6	2		30	7	5	1.5		30	9	7	1.5	
SWEET (ACACIA SMALLII)	15	6	2.5	0.75	MESQUITE						36	10	8	2.5		36	8	6	2		36	11	8	2	
	24	8	4	1.5							42	12	10	3		42	12	10	3		42	13	9	2.5	
	30	9	6	2	ARGENTINE MESQUITE (PROSOPIS ALBA)	15	6.5	2	0.75	SCREW BEAN (M) (PROSOPIS - PUBESCENS)	15	5.5	3	0.5	LITTLE LEAF FOOTHILLS (M) (CERCIDIUM - MICROPHYLLUM M)	15	4	3	0.5		48	16	10	3	
	36	10	8	2.5		24	8	4	1.5		24	8	4	1		24	5	4	1		48	16	10	3	
	42	12	10	3		30	9	6	2		30	9	6	1.5		30	6	5	1.5	ALEPPO (PINUS HALEPENSIS)	15	6	3	0.75	
	48	14	12	3.5		36	11	8	2.5		36	10	8	2		36	8	7	2		24	9	4	2	
SWEET (M) (ACACIA SMALLII)	15	5	3	0.5		42	13	10	3		42	12	10	3							30	11	6	3	
	24	8	5	1		48	15	12	3.5		48	14	12	3.5							36	14	7	3.5	
	30	9	7	1.5																	42	16	9	4	
	36	10	9	2																	48	18	10	4.5	
	42	12	10	2.5	See General Notes																				
	48	14	12	3	Detail 2600-3																				

Name	Size	Height	Width	Caliper	Name	Size	Height	Width	Caliper	Name	Size	Height	Width	Caliper	Name	Size	Height	Width	Caliper
MODESTO ASH (FRAXINUS V MODESTO)	15	8	2	1	RAYWOOD ASH	15	8	4	1	SILK TREE MIMOSA (M) (ALBISIA JULIBRISSIA)	15	5	3.5	0.5	SILK TREE MIMOSA (ALBISIA JULIBRISSIN)	15	6	3	0.75
	24	10	4	1.5	CLARET ASH	24	10	3	1.5		24	6.5	5	0.75		24	8	4	1.5
	30	12	6	2	(FRAXINUS O RAYWOODII)	30	12	5	2		30	6	6	1		30	10	6	2
	36	14	7	2.5		36	14	8	2.5		36	10	8	2.5		36	12	8	3
	42	16	8	3		42	16	10	3		SILVER DOLLAR GUM	15	7	3		0.75	TEXAS EBONY (M) (PITHECELLBIUM-FLEXICAULE)	15	4
48	17	10	3.5		48	18	12	4	(EUCALYPTUS-POLYANTHEMOS)	24	10	4	1.5	24	6	4		1	
NARROW LEAF GIMLET	15	6	2.5	0.75	RED CAP GUM	15	6.5	2.4	0.75	SISSOO (DALBERGIA SISSOO)	15	7	3	0.75		30	7	6	1.5
SWAMP MALLET (EUCALYPTUS -SPATHULATA)	24	8	3	1	(EUCALYPTUS-ERYTHROCORYES)	24	8	4	1.25		24	10	4	1.25		36	9	8	2
											30	12	7	2.5		48	11	11	3
OLEANDER (NERIUM OLEANDER)	15	7	2	0.75	RED GUM	15	8	3	1	SOUTHERN LIVE OAK HERITAGE (QUERCUS VIRGINIANA)	15	6	2	0.75	WEeping BOTTLE BRUSH (CALLISTEMON VIMINALIS)	15	8	2	0.75
	24	9	4	1.25	(EUCALYPTUS-CAMALDULENSIS)	24	10	4	1.75		24	9	4	1.25		24	10	3.5	1.5
	30	10	5	2		15	8	3	0.75		30	11	6.5	2		30	12	5	2
	36	12	6	2.5	RED IRON BARK	24	10	4	1.5		36	13	8	2.75		36	14	7	2.5
OLIVE TREE (OLEA EUROPAEA)	15	5	3	0.5	(EUCALYPTUS-SIDEROXYLON)					TEXAS EBONY (PITHECELLBIUM-FLEXICAULE)	42	15	10	3.5	WEeping WILLOW (SALIX BABYLONICA)	15	8	2	1
	24	8	5.5	1.5	RIO GRANDE FAN	15	7	2	0.75		48	17	12	4.5		24	10	4	1.5
	30	11	9	2		24	9	4	1.25		15	5	2	0.75		30	12	6	2.5
	36	12	10	3	TEXAS ASH	30	12	5	2		24	6	3	1.5		36	14	8	4
	42	14	12	3.5	(FRAXINUS V FANTEX)	36	14	8	2.5		42	15	9	3.5		WHITE IRON BARK	15	6.5	2.5
ORCHID TREE (BAUHINIA)	15	8	2	0.75		48	16	10	4		30	7	4	2	YELLOW OLEANDER (EUCALYPTUS -LEUCOXYLON)	24	8	3.5	1.25
	24	9	4	1.25	SHAMEL EVERGREEN	15	8	2	1		42	10	6	3		15	6	2	0.5
	30	11	6	2	(FRAXINUS UHDEI)	24	10	4	1.5		48	11	7	3.5		24	8	4	1.25
	36	13	7	2.5		30	12	5	2.5							YELLOW OLEANDER(M)	15	4	3.5
ORNAMENTAL PEAR (PYRUS CALLERYANA)	15	7	2	1		36	14	8	3						(THEVETIA PERUVIANA)	24	6	5	0.75
	24	10	3.5	1.5		42	15	9	3.5										
	30	12	6	2.5		48	16	10	4										
	36	14	8	3	SILK OAK	15	8	3	1										
	42	16	10	3.5	(GREVILLEA ROBUSTA)	24	10	4	2										
	48	18	12	4		30	12	6	2.5										
						36	14	7	3										

GENERAL NOTES:

1. All trees shall be guaranteed for one year from the date of acceptance
2. "M" designates a multitrunk tree. A multitrunk tree is a tree with more than one main trunk.
3. Caliper is measured at 12" above the ground for trees with caliper greater than 4". For multitrunk trees, and trees with caliper of less than 4", the caliper is measured 6" above the ground.
4. Size is listed as the box size in inches except for those trees in 15 gallon containers.

REVISED 7/29/96

Prune Tree At Time Of Stake Removal.

(2) 2" Diameter x 10' Long Lodgepole Pine Tree Stakes. Bury 3' In Ground And Cut Off Stake 12" Above Vinyl Tie. Stakes Shall Remain In Place For 2 Years Unless Removal Is Approved By Maintenance Director.

Mulch To A Depth Of 1/2", 5' In Diameter. Keep Mulch 6" Away From Trunk.

Backfill With Native Soil. (No Rocks Greater Than 1") Apply Fertilizer To Surface Away From Trunk Per Specifications.

Scarify One Side Of Root Ball Prior To Planting

Note: Sufficient clearance shall be maintained between trees and utility facilities so as to not hinder use of these facilities.

Vinyl Tie, 1" (Min.) In Width

Set Top Of Root Ball At Soil Surface.

Form Temporary Irrigation Border Just Outside Of Root Ball. Use Water To Settle Backfill. Do Not Pack Backfill.

Planting Hole Shall Be 3 Times Diameter Of Root Ball And No Deeper. Scarify Sides And Bottom Of Planting Hole

Tree Planting and Staking ≤36" Box Or 2" Caliper

Note: Sufficient clearance shall be maintained between shrubs and utility facilities so as to not hinder use of these facilities.

Mulch Soil To A Depth Of 2", 2' In Diameter For 1 Gal. Shrubs, 4' In Diameter For 5 Gal. Shrubs, Keep Mulch 4" Away From Plant Base.

Set Top Of Root Ball At Soil Surface.

Backfill With Native Soil. Apply Fertilizer To Surface Away From Trunk Per Specifications.

Planting Hole Shall Be 3 Times Diameter Of Root Ball And No Deeper. Scarify Sides And Bottom Of Planting Hole

Scarify One Side Of Root Ball Prior To Planting

Shrub Planting

All Groundcovers To Be Planted On Center (See Plant Legend) In A Triangular Pattern.

X = O.C. Dimension As Noted On Plan

Y = 0.86 Of Dimension "X"

Mulch Soil To A Depth Of 2", 1' In Diameter. Keep Mulch 2" Away From Plant Base.

Prepare Soil Per Specifications And Rototill To A Depth Of 6" Prior To Any Sprinkler Work.

Backfill With Native Soil. Apply Fertilizer To Surface Away From Trunk Per Specifications.

Groundcovers

Decomposed Granite Finish Grade To Be Raked Smooth.

Provide Final Application Of Weed Control Upon Final Raking.

2" Min.

Fine Graded Subgrade

Apply Pre-Emergent Herbicide As Per Manufacturers Recommendations. (Surflan Or Equal Approved By City Of Scottsdale)

Decomposed Granite

DETAIL NO. 2620-1	City of Scottsdale Standard Details	APPROVED BY: Scottsdale Standards & Specifications Committee	LANDSCAPE DETAILS	DETAIL NO. 2620-1
-----------------------------	--	--	--------------------------	-----------------------------

REVISED 1/5/00

Garden Hose Reinforced With Wire (Metal).

Use Golf Sand Or 1/4" Minus Decomposed Granite To Backfill Planting Hole. Backfill 1/2 Of Pit, Then Compact.

Root Prune All Shredded Or Damaged Roots And Dust Entire Root Structure With Wettable Sulphur (1.5 Min.) And Streptomycin Spray At Planting Site. Root Ball Minimum Size Shall Be 24" With A Minimum Root Length Of 6" On All Sides.

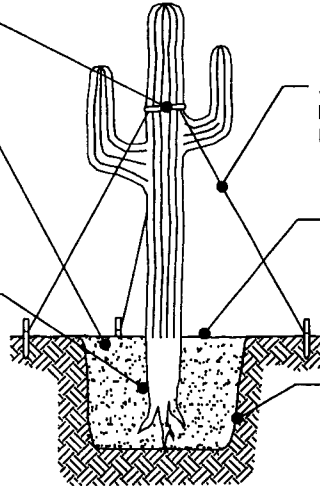

3 Tree Braces, Spaced Equally. Braces To Remain In Place For One Year Min.

6 - 1 Gallon Emitters In 'Hula Hoop' Distribution, Run Once A Month 24 To 48 Hours For One Year.

Planting Hole Width Shall Be 3 Times Diameter Of Roots And No Deeper Than The Extension Of The Roots.

Saguaro Planting Type A

NOTES:

1. Optimum transplanting season is October thru November.
2. Maintain original plant orientation. The original "North" orientation shall be marked on a rib at a height of 5' above ground level.
3. Water thoroughly at the time of transplanting to remove air pockets and assure proper compaction. Backfill shall be free of injurious rocks and debris.
4. Do not water for 3 weeks after planting.
5. Plant in areas safe from present and future construction activities.
6. Transplant to original depth of bury.

NOTE: Water weekly through the summer.

Plant At Depth Which Plant Was Grown.

Planting Mix To Be 1/3 Golf Sand And 2/3 Specified Soil. Pack The Backfill Mix, Do Not Use Water To Settle Backfill Mix.

Planting Hole Width Shall Be 3 Times Diameter Of Roots And No Deeper Than The Extension Of The Roots.

Use 6" to 8" Rocks To Anchor Roots.

Root Prune All Shredded Or Damaged Roots And Dust Entire Root Structure With Wettable Sulphur (1.5 min.) At Planting Site.

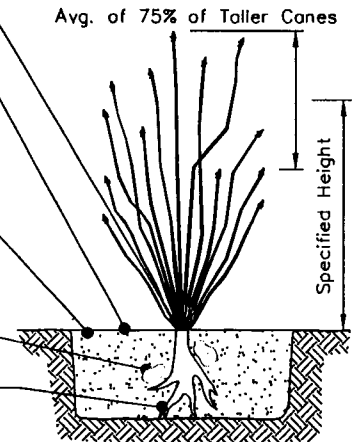

Ocotillo Planting

(3) 2"x 6" Braces, Spaced Equally And Nailed To Wooden Stakes In The Ground. Braces To Remain In Place For One Year Min.

Use Golf Sand Or 1/4" Minus Decomposed Granite To Backfill Planting Hole. Backfill 1/2 Of Pit, Then Compact.

Root Prune All Shredded Or Damaged Roots And Dust Entire Root Structure With Wettable Sulphur (1.5 Min.) And Streptomycin Spray At Planting Site. Root Ball Minimum Size Shall Be 24" With A Minimum Root Length Of 6" On All Sides.

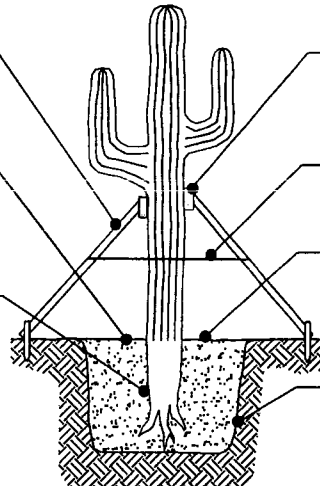

4"x 8"- Dense Foam And Carpet Padded, 8' Above Natural Grade And Nailed To Brace.

Steel Band Fastened With 2 Large Staples Per Brace.

6 - 1 Gallon Emitters In 'Hula Hoop' Distribution, Run Once A Month 24 To 48 Hours For One Year.

Planting Hole Width Shall Be 3 Times Diameter Of Roots And No Deeper Than The Extension Of The Roots.

Saguaro Planting Type B

NOTES:

1. Optimum transplanting season is October thru November.
2. Maintain original plant orientation. The original "North" orientation shall be marked on a rib at a height of 5' above ground level.
3. Water thoroughly at the time of transplanting to remove air pockets and assure proper compaction. Backfill shall be free of injurious rocks and debris.
4. Do not water for 3 weeks after planting.
5. Plant in areas safe from present and future construction activities.
6. Transplant to original depth of bury.

NOTES: Water weekly through the summer. Maintain original growing orientation.

Plant At Depth Which Plant Was Grown.

Planting Mix To Be 1/3 Golf Sand And 2/3 Specified Soil. Pack The Backfill Mix, Do Not Use Water To Settle Backfill Mix.

Planting Hole Width Shall Be 3 Times Diameter Of Roots And No Deeper Than The Extension Of The Roots.

Use 6" to 8" Rocks To Anchor Roots.

Root Prune All Shredded Or Damaged Roots And Dust Entire Root Structure With Wettable Sulphur (1.5 min.) At Planting Site.

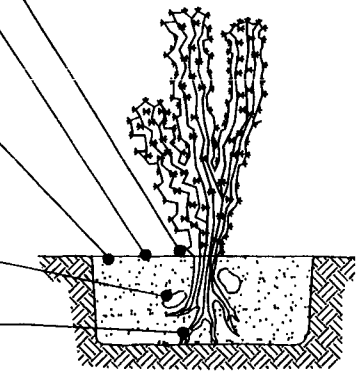

Cactus Planting

DETAIL NO.
2620-2

**City of Scottsdale
Standard Details**

APPROVED BY:
**Scottsdale Standards &
Specifications Committee**

LANDSCAPE DETAILS

DETAIL NO.
2620-2

REVISED 1/5/00

Staking Required For Trees In 36" Box Or Less Or With A Caliper Of Less Than 2". (2) 2" Diameter x 10' Long Lodgepole Pine Tree Stakes. Bury 3' In Ground And Cut Off Stake 12" Above Vinyl Tie. Stakes Shall Remain In Place For 2 Years Unless Removal Is Approved By Maintenance Director.

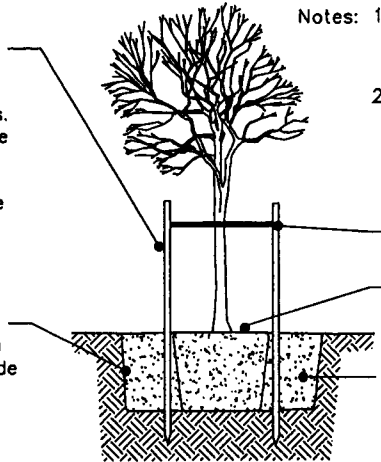

Backfill With Native Soil. (No Rocks Greater Than 3") Backfill 3/4 The depth Of Rootball Before Removing Box Side Panels. Compact Backfill As Needed To Prevent Breaking Rootball.

- Notes:
1. Sufficient clearance shall be maintained between trees and utility facilities so as to not hinder use of these facilities.
 2. Plant pit basins within sloped planting areas shall be constructed with a max. 2:1 slope. Provide smooth transition to surrounding finish grade.

- Vinyl Tie, 1" (Min.) In Width
- Set Top Of Root Ball At Soil Surface.
- Planting Hole Shall Be 2 Times Diameter Of Root Ball And No Deeper. Scarify Sides And Bottom Of Planting Hole

Salvaged Tree Planting

(LEFT BLANK)

Thin Top 6-8 Fronds, Tie With Natural Fiber Twine. (Remove Ties Prior To Buckling 60-90 Days).

Plant At Depth Which Plant Was Grown. Adjusting Root Ball Depth To Align Finished Height Will Not Be Allowed.

100% Golf Sand Backfill. Settle Backfill With Water, Do Not Pack Backfill.

Planting Hole Width Shall Be 3 Times Diameter Of Roots And No Deeper Than The Extension Of The Roots.

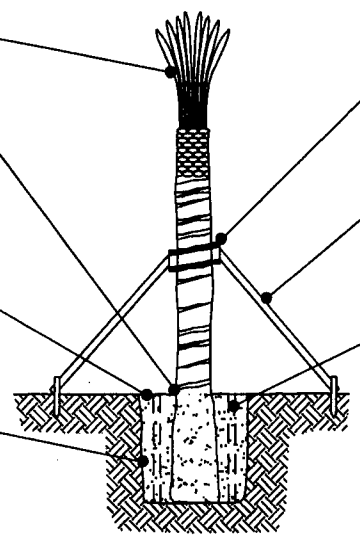

2"x 4" Blocking Nailed To Brace. Tie To Trunk With 1" (Min.) Vinyl Tie.

(3) 2"x 6" Braces, Spaced Equally And Nailed To Wooden Stakes In The Ground.

4" Perforated PVC, 2 Per Tree. Wrap PVC With Soil Screen Fabric.

Palm Planting and Bracing Detail

(LEFT BLANK)

DETAIL NO. **2620-3** City of Scottsdale Standard Details

APPROVED BY: **Scottsdale Standards & Specifications Committee**

LANDSCAPE DETAILS

DETAIL NO. **2620-3**

SCORPIO UHF ANTENNA (UHF NORTHPOINT
LOPRO ANTENNA, NP 4000, 450-470 MHZ
OR APPROVED EQUAL)

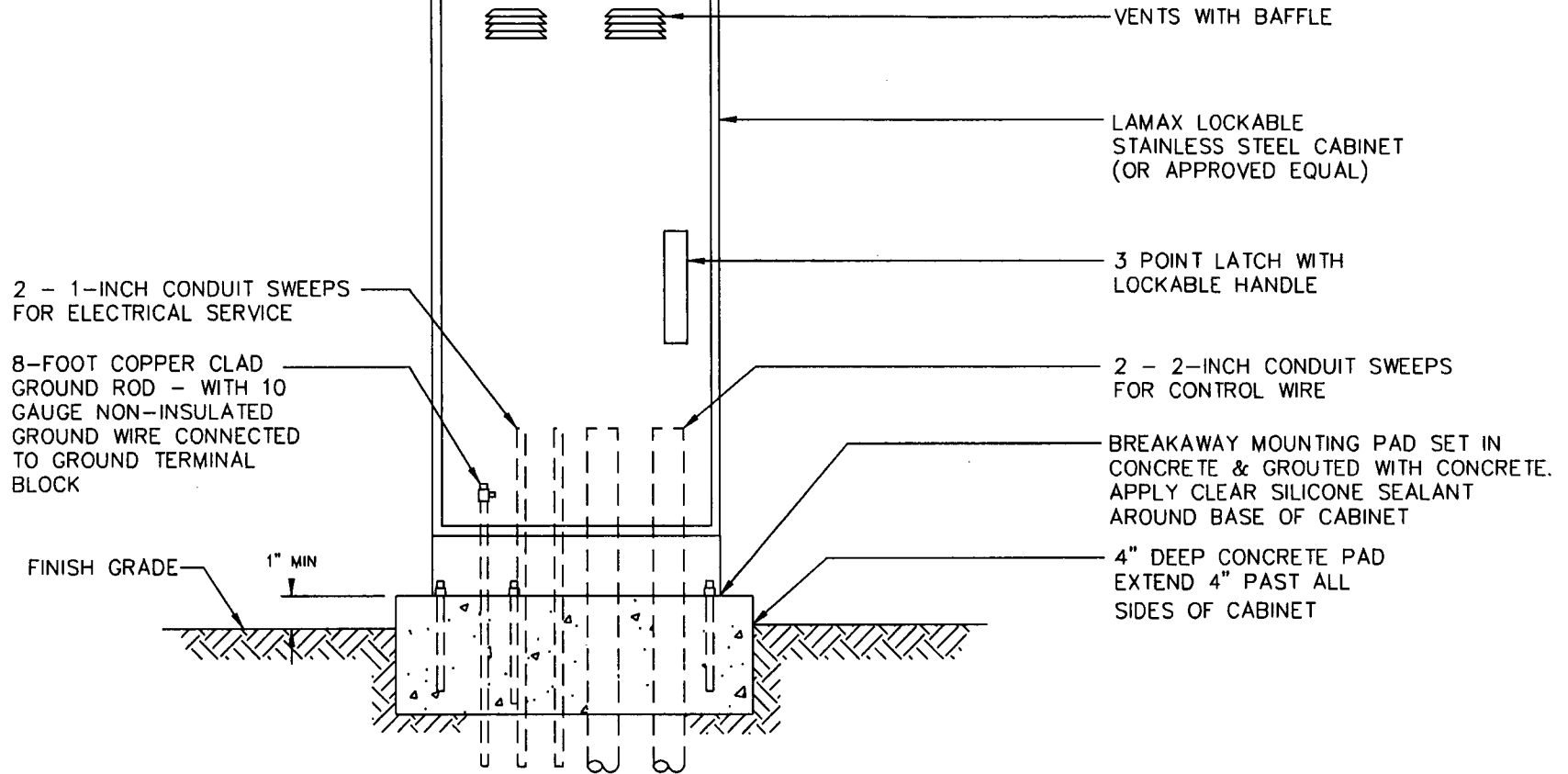

2 - 1-INCH CONDUIT SWEEPS
FOR ELECTRICAL SERVICE

8-FOOT COPPER CLAD
GROUND ROD - WITH 10
GAUGE NON-INSULATED
GROUND WIRE CONNECTED
TO GROUND TERMINAL
BLOCK

FINISH GRADE

1" MIN

VENTS WITH BAFFLE

LAMAX LOCKABLE
STAINLESS STEEL CABINET
(OR APPROVED EQUAL)

3 POINT LATCH WITH
LOCKABLE HANDLE

2 - 2-INCH CONDUIT SWEEPS
FOR CONTROL WIRE

BREAKAWAY MOUNTING PAD SET IN
CONCRETE & GROUTED WITH CONCRETE.
APPLY CLEAR SILICONE SEALANT
AROUND BASE OF CABINET

4" DEEP CONCRETE PAD
EXTEND 4" PAST ALL
SIDES OF CABINET

NOTES:

1. POWER SOURCE FOR CONTROLLER TO BE HARD WIRED FROM CIRCUIT BREAKER MOUNTED INSIDE CABINET TO CONTROLLER.
2. LOCATION OF POWER SOURCE TO BE NOTED ON CIRCUIT BREAKER PANEL.
3. REMOTE CONTROL VALVES FOR D.C. SCORPIO APPLICATIONS MUST HAVE D.C. LATCHING SOLENOIDS AND APPROVED SOLAR PANEL FOR POWER SOURCE.
4. JSLM NARROW BAND RADIO # 2845 G TO BE INSTALLED WITH SCORPIO CONTROLLER.
5. PROGRAMMING KEYPAD TO BE SUPPLIED WITH CONTROLLER.
6. CONTROLLER TO BE LOCATED IN AREA WITH POSITIVE DRAINAGE.
7. INSTALL ONLY ONE CONTROL VALVE WIRE PER CONTROLLER OUTPUT.
8. UHF RADIO TO BE TUNED TO C.O.S. FREQUENCIES. CONTACT IRRIGATION DEPARTMENT FOR INFORMATION (480-312-2189)

DETAIL NO.
2632

City of Scottsdale
Standard Details

APPROVED BY:
Scottsdale Standards &
Specifications Committee

SCORPIO PEDESTAL MOUNTED CONTROLLER

DETAIL NO.
2632

REVISED: 7/15/03

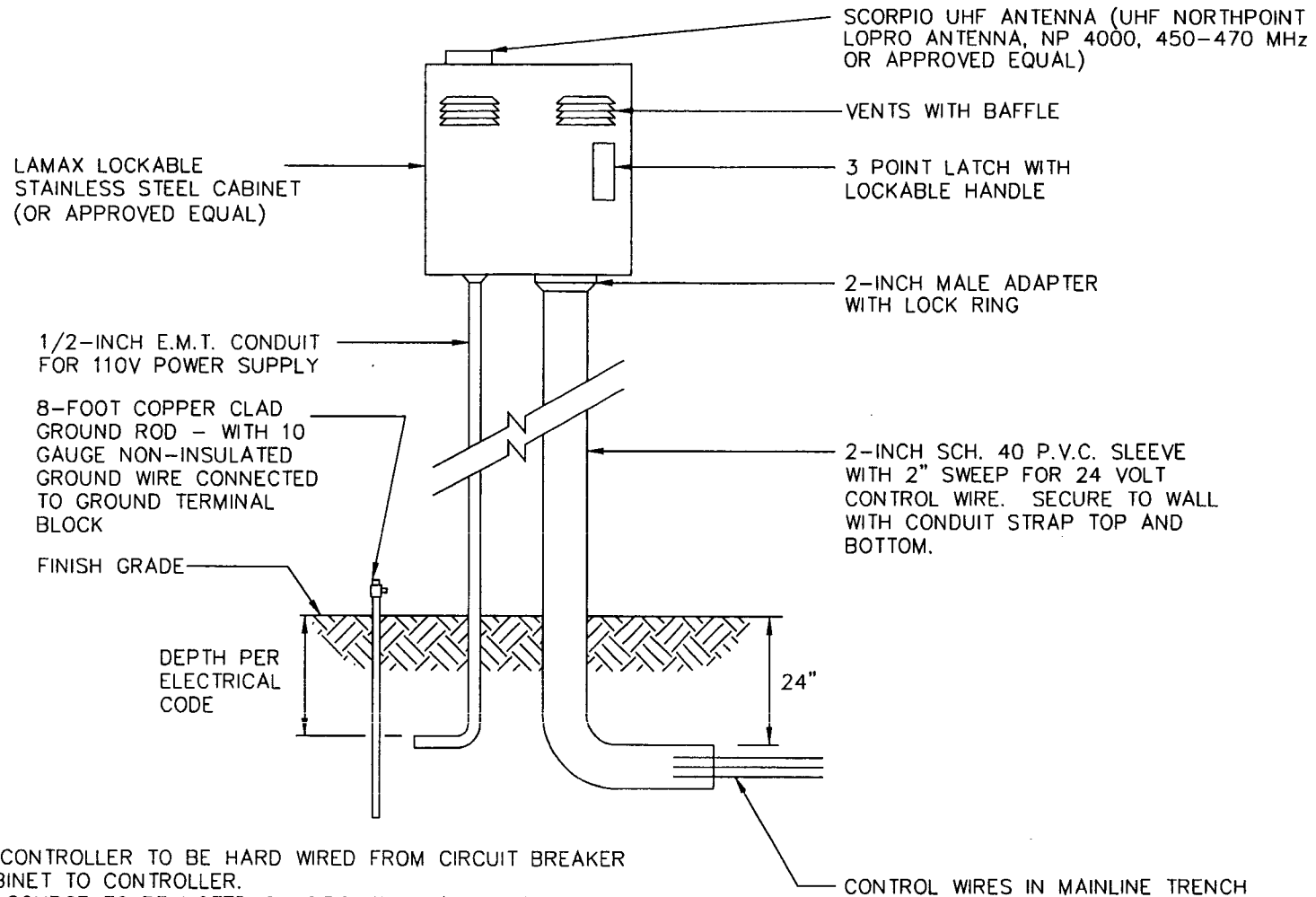

NOTES:

1. POWER SOURCE FOR CONTROLLER TO BE HARD WIRED FROM CIRCUIT BREAKER MOUNTED INSIDE CABINET TO CONTROLLER.
2. LOCATION OF POWER SOURCE TO BE NOTED ON CIRCUIT BREAKER PANEL.
3. REMOTE CONTROL VALVES FOR D.C. SCORPIO APPLICATIONS MUST HAVE D.C. LATCHING SOLENOIDS AND APPROVED SOLAR PANEL FOR POWER SOURCE.
4. JSLM NARROW BAND RADIO #2845 G TO BE INSTALLED WITH SCORPIO CONTROLLER.
5. PROGRAMMING KEYPAD TO BE SUPPLIED WITH CONTROLLER.
6. INSTALL ONLY ONE CONTROL VALVE WIRE PER CONTROLLER OUTPUT.
7. UHF RADIO TO BE TUNED TO C.O.S. FREQUENCIES. CONTACT IRRIGATION DEPARTMENT FOR INFORMATION (480-312-2189)

DETAIL NO.
2633

City of Scottsdale
Standard Details

APPROVED BY:
Scottsdale Standards &
Specifications Committee

SCORPIO WALL MOUNTED CONTROLLER

DETAIL NO.
2633

REVISED: 4/25/02

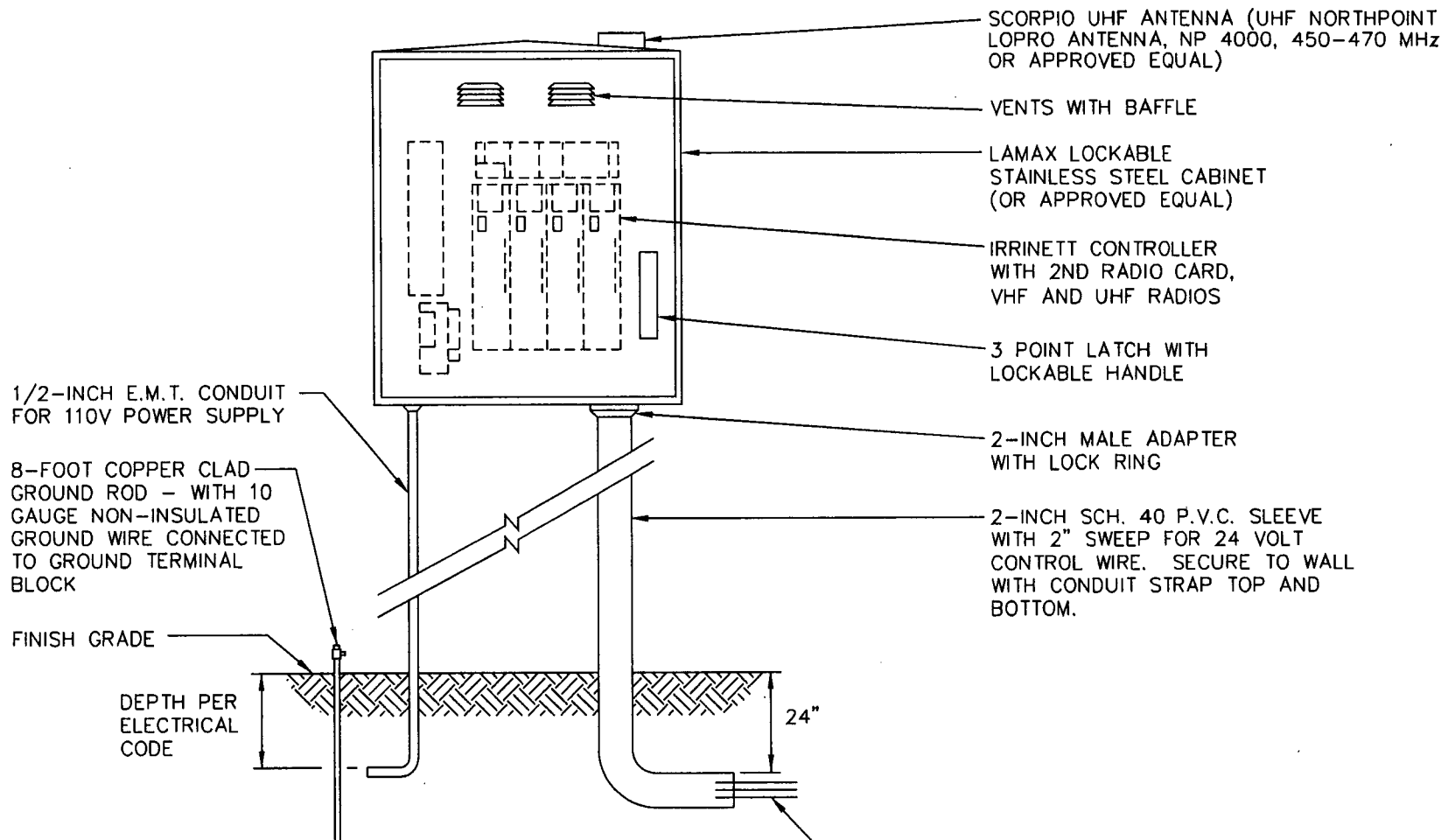

SCORPIO UHF ANTENNA (UHF NORTHPOINT LOPRO ANTENNA, NP 4000, 450-470 MHz OR APPROVED EQUAL)

VENTS WITH BAFFLE

LAMAX LOCKABLE STAINLESS STEEL CABINET (OR APPROVED EQUAL)

IRRINET CONTROLLER WITH 2ND RADIO CARD, VHF AND UHF RADIOS

3 POINT LATCH WITH LOCKABLE HANDLE

2-INCH MALE ADAPTER WITH LOCK RING

2-INCH SCH. 40 P.V.C. SLEEVE WITH 2" SWEEP FOR 24 VOLT CONTROL WIRE. SECURE TO WALL WITH CONDUIT STRAP TOP AND BOTTOM.

1/2-INCH E.M.T. CONDUIT FOR 110V POWER SUPPLY

8-FOOT COPPER CLAD GROUND ROD - WITH 10 GAUGE NON-INSULATED GROUND WIRE CONNECTED TO GROUND TERMINAL BLOCK

FINISH GRADE

DEPTH PER ELECTRICAL CODE

24"

CONTROL WIRES IN MAINLINE TRENCH

NOTE:

1. POWER SOURCE FOR CONTROLLER TO BE HARD WIRED FROM CIRCUIT BREAKER MOUNTED INSIDE CABINET TO CONTROLLER.
2. LOCATION OF POWER SOURCE TO BE NOTED ON CIRCUIT BREAKER PANEL.
3. PROGRAMMING KEYPAD TO BE SUPPLIED WITH CONTROLLER.
4. INSTALL ONLY ONE CONTROL VALVE WIRE PER CONTROLLER OUTPUT.
5. VHF AND UHF RADIOS TO BE TUNED TO C.O.S. FREQUENCIES. CONTACT IRRIGATION DEPARTMENT FOR INFORMATION (480-312-2189)

DETAIL NO. 2634

City of Scottsdale Standard Details

APPROVED BY: Scottsdale Standards & Specifications Committee

IRRINET WALL MOUNTED CONTROLLER

DETAIL NO. 2634

NOTES:

1. INSTALL WIRE OF APPROPRIATE GAUGE, CONNECTORS, SEALANT, AND ADAPTORS PER MANUFACTURERS INSTRUCTIONS.
2. D.C. LATCHING SOLENOIDS ON REMOTE CONTROL VALVES TO BE COMPATIBLE WITH CONTROLLER.
3. MASTER VALVE TO BE INSTALLED AND WIRED TO CONTROLLER. RAINBIRD GB VALVE, SAME SIZE AS MAINLINE INSTALLED PER COS DETAIL #2654 (REMOTE CONTROL VALVE) WITH DC LATCHING SOLENOID COMPATIBLE WITH CONTROLLER.
4. PROGRAMMING/ACCESS KEY TO BE SUPPLIED WITH CONTROLLER.
5. INSTALL MANUFACTURERS STAINLESS STEEL ENCLOSURE FOR CONTROLLER.
6. PROVIDE 12" EXANSION COIL FOR EACH WIRE SPLICE INSIDE SPLICE BOX WHEN SPLICES ARE REQUIRED BY MANUFACTURER.

CARSON / BROOKS 10-INCH ROUND VALVE BOX WITH LOCKING "T" STYLE COVER.
(SUPPLY WITH STAINLESS STEEL BOLTS)

EPOXY FILLED TWO PIECE CYLINDER WIRE CONNECTOR

BRICK PAVER (1 OF 3)

24"

CONTROLLER MOUNTING TUBE

36"

FINISH GRADE

12"x12"x12" CONCRETE BASE

12"

PVC SWEEP

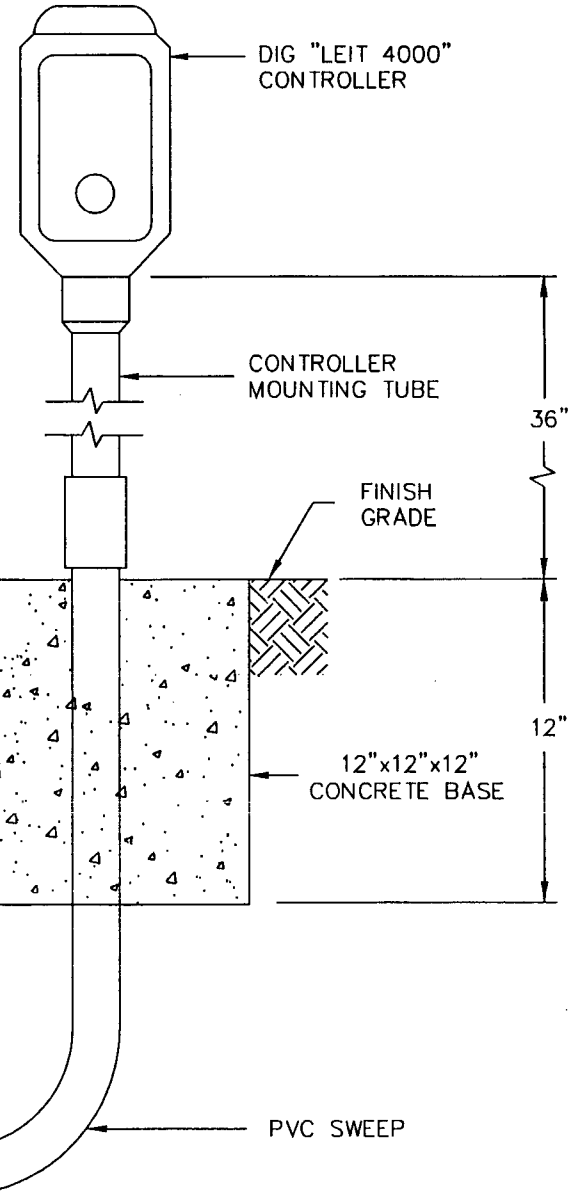

REVISED: 4/26/02

DETAIL NO.
2635-1

City of Scottsdale
Standard Details

APPROVED BY:
Scottsdale Standards &
Specifications Committee

SOLAR CONTROLLER

DETAIL NO.
2635-1

NOTES:

1. INSTALL WIRING OF APPROPRIATE GAUGE, CONNECTORS, SEALANT, AND ADAPTORS PER MANUFACTURERS INSTRUCTIONS.
2. INSTALL CONTROL WIRES, SPLICES, AND MOUNTING COLUMN AS FURNISHED/SPECIFIED BY THE CONTROLLER MANUFACTURER.
3. LABEL ALL WIRES IN CONTROLLER.
4. D.C. LATCHING SOLENOIDS ON REMOTE CONTROL VALVES TO BE COMPATIBLE WITH CONTROLLER.
5. MASTER VALVE TO BE INSTALLED AND WIRED TO CONTROLLER. RAINBIRD GB VALVE, SAME SIZE AS MAINLINE INSTALLED PER COS DETAIL #2654 (REMOTE CONTROL VALVE) WITH DC LATCHING SOLENOID COMPATIBLE WITH CONTROLLER.
6. REFER TO COS DET 2354 FOR ADDITIONAL BACKFLOW PREVENTION DEVICE DETAILS.
7. PROGRAMMING/ACCESS KEY TO BE PROVIDED WITH CONTROLLER.
8. PROVIDE 12" EXANSION COIL FOR EACH WIRE SPLICE INSIDE SPLICE BOX WHEN SPLICES ARE REQUIRED BY MANUFACTURER.

REVISED4/26/02

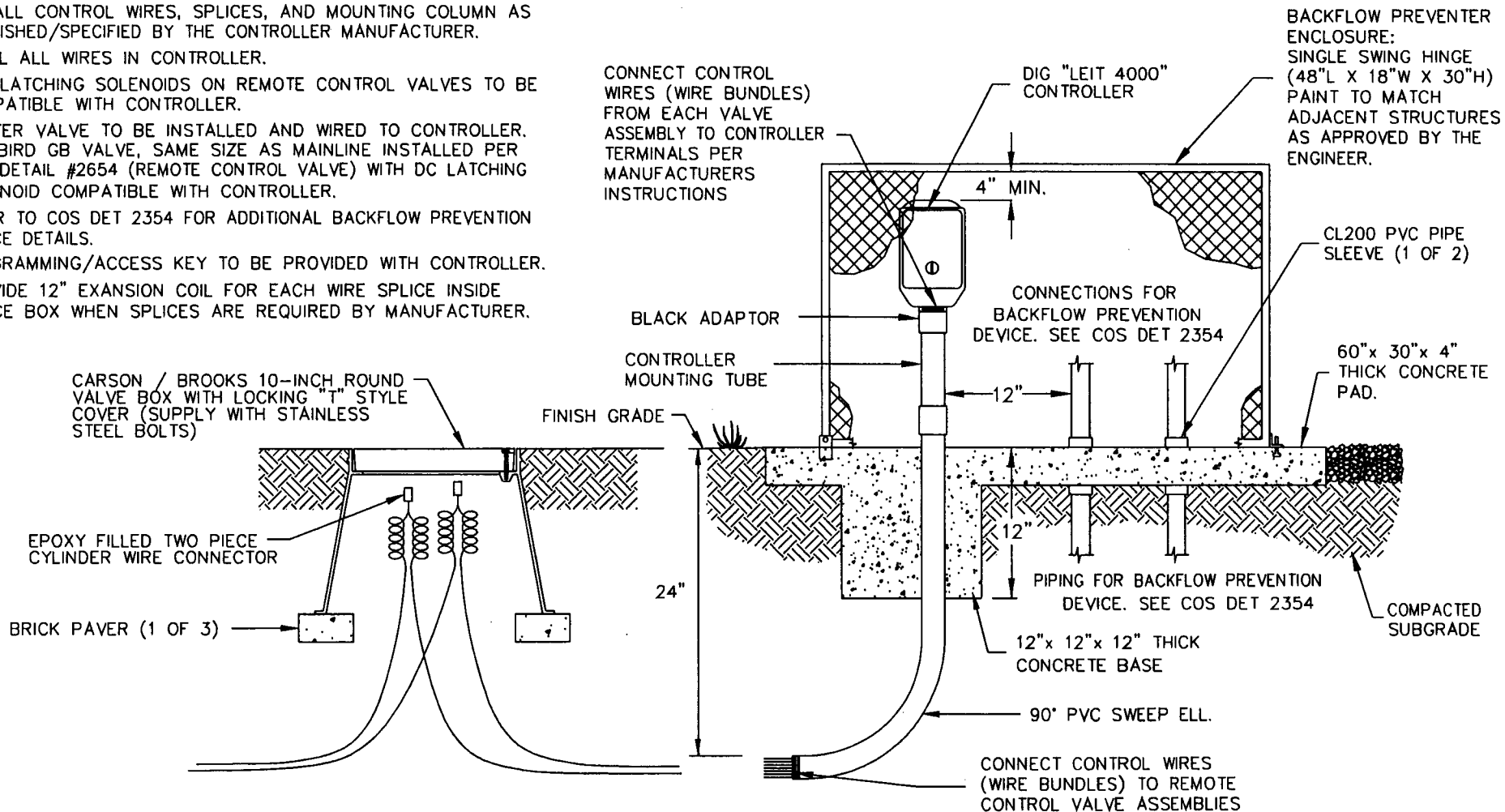

DETAIL NO.
2635-2

**City of Scottsdale
Standard Details**

APPROVED BY:
**Scottsdale Standards &
Specifications Committee**

SOLAR CONTROLLER AND BACKFLOW PREVENTER ENCLOSURE

DETAIL NO.
2635-2

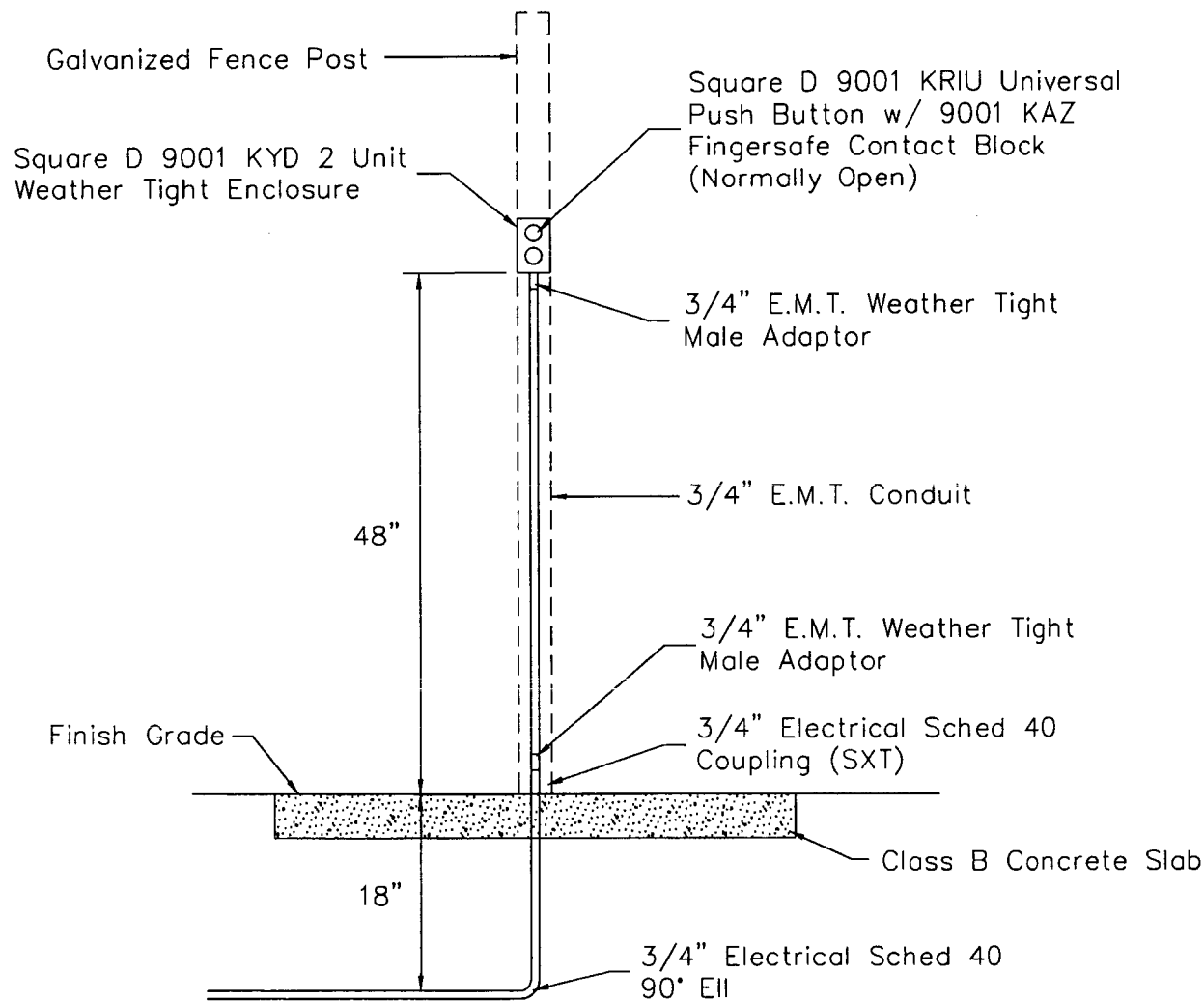

NOTES:

1. Install #14 ga. irrigation control wire.
2. Install one control wire per push button. Control wire to be different color from all other irrigation control wires.
3. Common wire (#12 ga) for push buttons shall be a separate common wire and not part of the irrigation control valve common wire.
4. Push button common wire to have color stripe matching push button control wire. The common wire may be shared by other push buttons.
5. Attach push button enclosure to galvanized post with two self-tapping hex head screws.
6. For other configurations/applications, contact Irrigation Dept 480-312-2189.
7. Label control wires inside enclosure and at controller to differentiate their functionality.

DETAIL NO.
2636

City of Scottsdale
Standard Details

APPROVED BY:
Scottsdale Standards & Specifications Committee

IRRIGATION PUSH BUTTON CONTROL

DETAIL NO.
2636

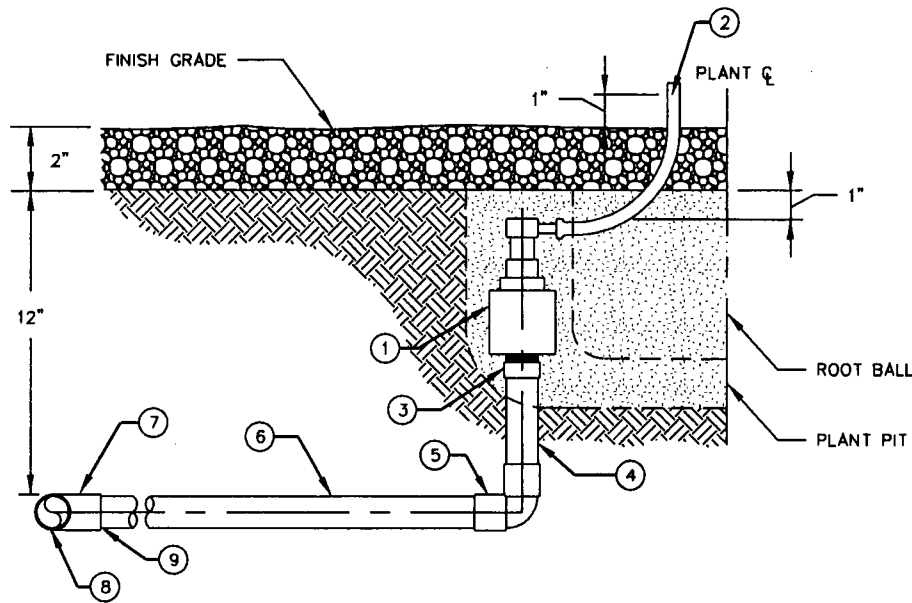

**SINGLE OUTLET EMITTER
ALL SHRUBS & GROUND COVER**

SCALE: NTS

LIST OF MATERIALS

- ① BOWSMITH SL - SERIES SINGLE PORT EMITTER OR APPROVED EQUAL. LOCATE ON UPHILL SIDE OF PLANT CENTERLINE
- ② 1/4" POLY FLEX HOSE EMITTER TUBING
- ③ 1/2" PVC SCH 40 MALE ADAPTOR
- ④ AG. PRODUCTS - 1/2" I.P.S. FLEXIBLE VINYL PVC PIPE OR APPROVED EQUAL
- ⑤ 1/2" PVC SCH 40 90° ELBOW
- ⑥ 1/2" PVC CL 315 PIPE
- ⑦ 1/2" PVC SCH 40 FITTING
- ⑧ PVC CL 315 FOR 1/2" LATERALS, PVC CL 200 FOR LATERALS GREATER THAN 1/2"
- ⑨ INSTALL BUSHING AS REQUIRED.

NOTES

- 1. PIPE CEMENT & PRIMER SHALL BE AS SPECIFIED BY MANUFACTURER FOR FLEXIBLE AND RIGID PIPE CONNECTIONS.
- 2. EMITTER TUBING EMISSION POINTS SHALL BE EQUALLY SPACED AND LOCATED TO DIRECT WATER FLOW TO THE PERIMETER OF THE DRIP LINE.
- 3. NUMBER OF OPENINGS AND EMITTER TUBES REQUIRED IS BASED ON PLANT SIZE. (SEE COS STD. DET. 2641-2)
- 4. MAXIMUM EMITTER TUBING LENGTH = 36".

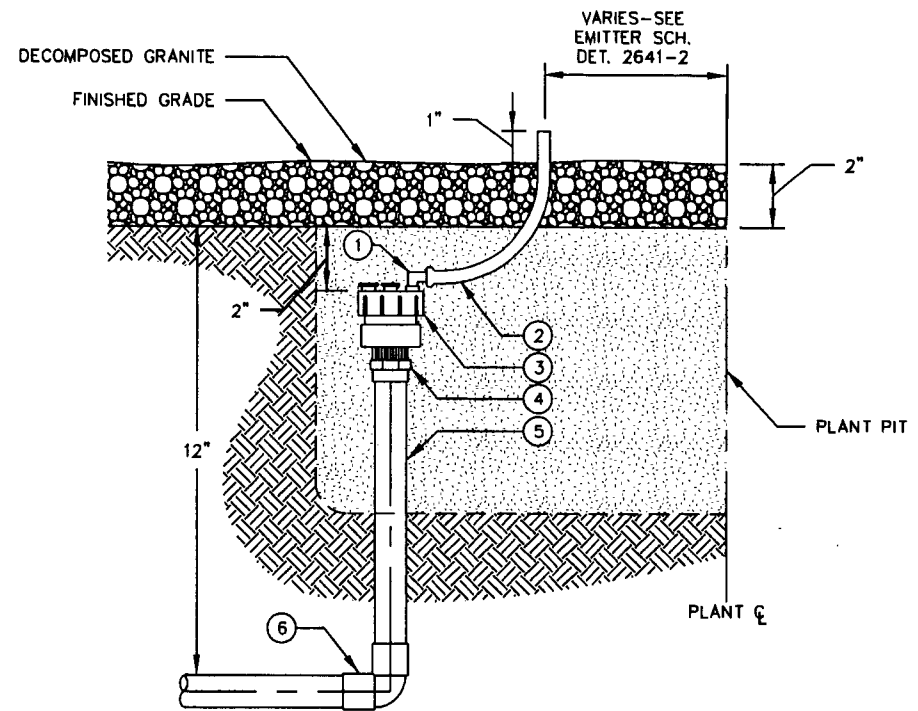

**MULTI-OUTLET EMITTER
TREES ONLY**

SCALE: NTS

LIST OF MATERIALS

- ① SWIVEL OUTLET 90° ELBOW
- ② 1/4" POLY FLEX HOSE EMITTER TUBING
- ③ BOWSMITH ML 200 SERIES MULTI-PORT EMITTER OR APPROVED EQUAL. LOCATE ON UPHILL SIDE OF PLANT CL
- ④ 1/2" PVC SCH 40 MALE ADAPTER
- ⑤ AG. PRODUCTS 1/2" I.P.S. FLEXIBLE VINYL PVC PIPE OR APPROVED EQUAL
- ⑥ 1/2" PVC SCH 40 FITTING

DETAIL NO.
2641-1

City of Scottsdale
Standard Details

APPROVED BY:
Scottsdale Standards &
Specifications Committee

SINGLE & MULTI-OUTLET EMITTERS

DETAIL NO.
2641-1

REVISED 7/29/96

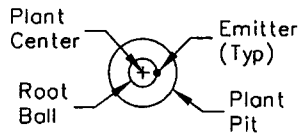

**SHRUB EMITTER
SINGLE OUTLET**

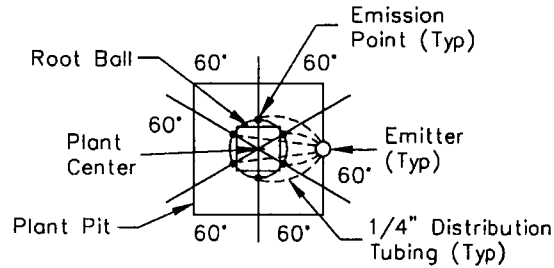

**TREE EMITTER - MULTI OUTLET
15 GAL TO 42" BOX TREES**

(SEE EMITTER SCHEDULE)

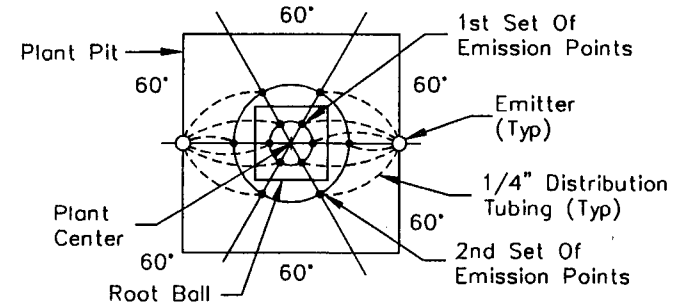

**TREE EMITTER - MULTI OUTLET
48" BOX TO 60" BOX TREES**

(SEE EMITTER SCHEDULE)

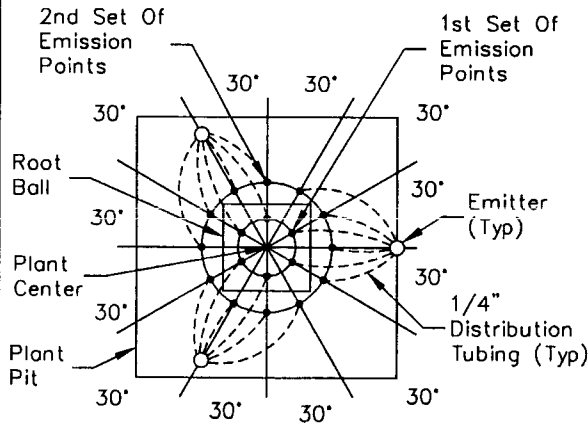

**TREE EMITTER - MULTI OUTLET
66" BOX TO 84" BOX TREES**

(SEE EMITTER SCHEDULE)

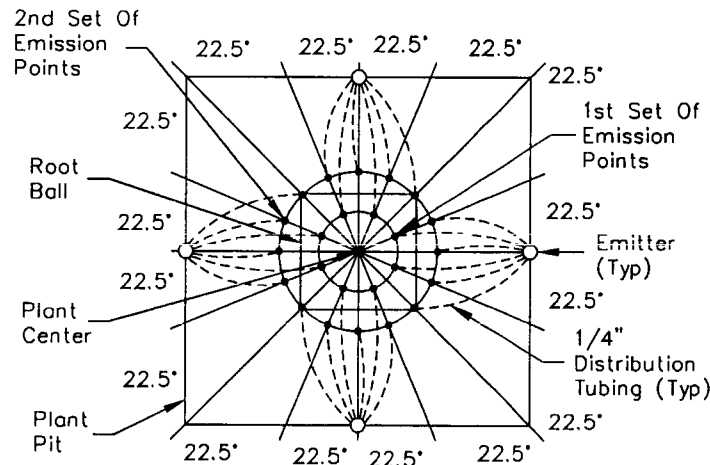

**TREE EMITTER - MULTI OUTLET
96" BOX TREES**

(SEE EMITTER SCHEDULE)

EMITTER SCHEDULE			
Tree Size	Number Of Multi Outlet Emitters - Outlet Quantity = Emitter GPH Total	Distance From Trunk	
		1st Set Of Emission Points	2nd Set Of Emission Points
15 Gal.	1-1 GPH=6 GPH	3 @ 12"	
24" Box	1-1 GPH=6 GPH	4 @ 18"	
30" Box	1-1 GPH=6 GPH	6 @ 21"	
36" Box	1-2 GPH=12 GPH	6 @ 24"	
42" Box	1-2 GPH=12 GPH	6 @ 27"	
48" Box	2-2 GPH=24 GPH	6 @ 12"	4 @ 42"
54" Box	2-2 GPH=24 GPH	6 @ 15"	5 @ 45"
60" Box	2-2 GPH=24 GPH	6 @ 18"	6 @ 48"
66" Box	3-2 GPH=36 GPH	6 @ 24"	12 @ 54"
72" Box			
78" Box	3-2 GPH=36 GPH	6 @ 30"	12 @ 60"
84" Box			
≥ 90" Box	4-2 GPH=48 GPH	8 @ 33"	16 @ 66"

DETAIL NO.

2641-2

**City of Scottsdale
Standard Details**

APPROVED BY:

**Scottsdale Standards &
Specifications Committee**

IRRIGATION EMITTER LAYOUT

DETAIL NO.

2641-2

REVISED: 4/18/05

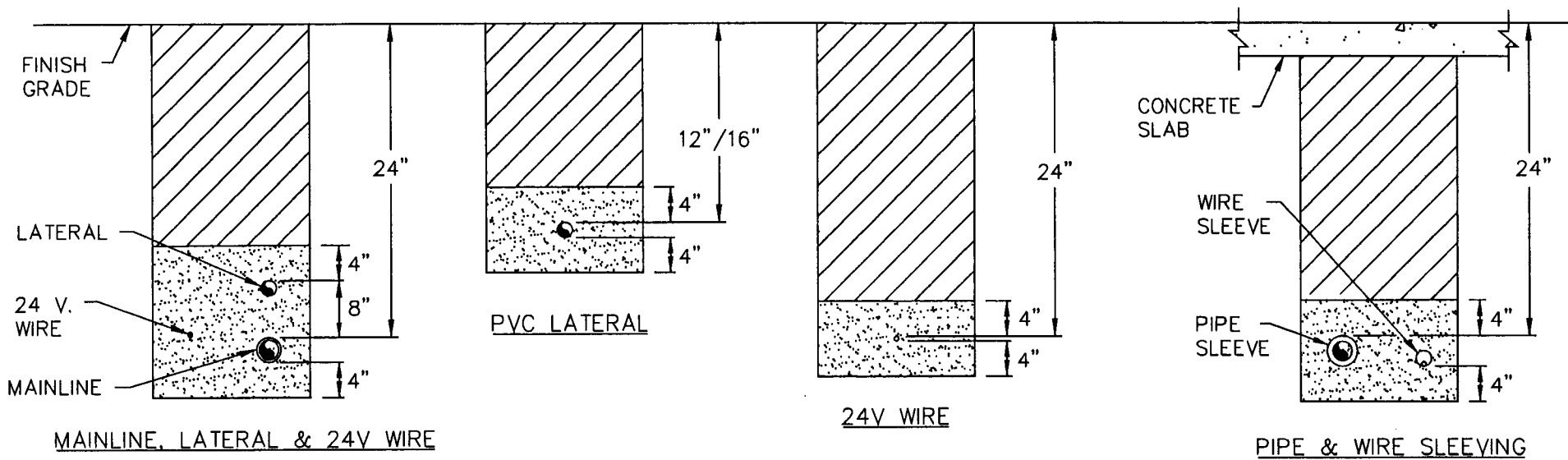

MAINLINE, LATERAL & 24V WIRE

24V WIRE

PIPE & WIRE SLEEVING

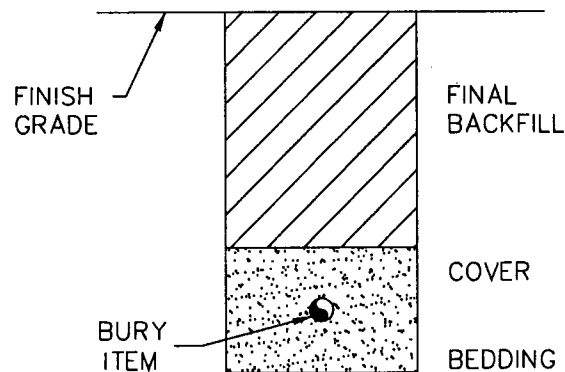

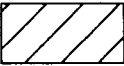
 EXCAVATED MATERIAL SHALL BE FINELY SCREENED WITH NO ROCKS LARGER THAN 1".

 BEDDING AND COVER MATERIAL SHALL BE TOPSOIL WITH NO ROCKS.

NOTES:

1. BEDDING SHALL BE PLACED AND LEVELED PRIOR TO INSTALLATION OF BURY ITEM.
2. BACKFILL SHALL BE PLACED IN MAXIMUM 6" LIFTS.
3. SLEEVE ALL PIPE AND WIRE SEPARATELY. SLEEVE 2 X DIA. OF PIPE. ONE PIPE PER SLEEVE.
4. ALL PIPE TO BE INSTALLED PER MANUFACTURES SPECIFICATIONS WITH PIPE LABELING FACING UP FOR INSPECTION PURPOSES. PROVIDE A MINIMUM OF 2" CLEARANCE TO SIDE OF TRENCH AND BETWEEN PIPES.
5. ALL 120 V. WIRING SHALL BE INSTALLED IN ACCORDANCE WITH LOCAL CODE REQUIREMENTS.
6. TAPE AND BUNDLE IRRIGATION CONTROL WIRES EVERY 10'. PROVIDE LOOSE 20" LOOP AT ALL CHANGES OF DIRECTION OVER 30".
7. ALL REMOTE CONTROL VALVE WIRING NOT INSTALLED WITH MAINLINE PIPE SHALL BE INSTALLED IN A MINIMUM 2" SCHEDULE 40 GREY ELECTRICAL CONDUIT OR AS APPROVED.
8. "NON-POTABLE" WARNING TAPE TO BE INSTALLED ON ALL PRESSURIZED MAINLINES 12" ABOVE THE PIPE.
9. INSTALL ONE ADDITIONAL SLEEVE SIZED TO MATCH THE LARGEST REQUIRED SLEEVE WITH ENDS TAPED FOR FUTURE USE.

DETAIL NO.
2642

City of Scottsdale
Standard Details

APPROVED BY:
Scottsdale Standards &
Specifications Committee

IRRIGATION TRENCHING

DETAIL NO.
2642

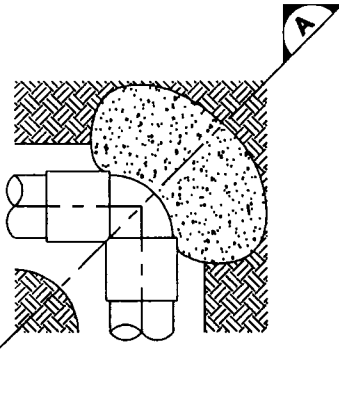

90° ELL

SCALE: NTS

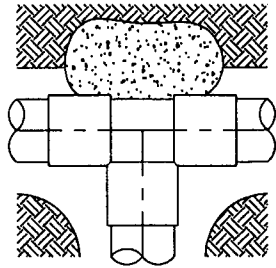

TEE

SCALE: NTS

PIPE SIZE	MINIMUM THRUST BLOCK AREA (YxW)	
	IRRIGATION PIPE	
2" & LESS	TEE, DEAD END 90° BEND	45', 22.5'
3"		5 SF
4"		1 SF
5" & LARGER		2 SF
		PER MAG DETAIL 380

NOTES

1. MINIMUM THRUST BLOCK AREAS ARE BASED ON A SOIL BEARING CAPACITY OF 3000 LBS/SF
2. THRUST BLOCK SHALL EXTEND INTO UNDISTURBED SOIL.
3. THRUST BLOCK SHALL BE MAG SECT. 725-CLASS C.

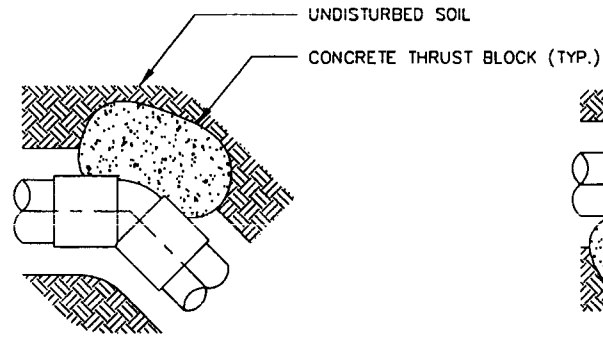

45° ELL

SCALE: NTS

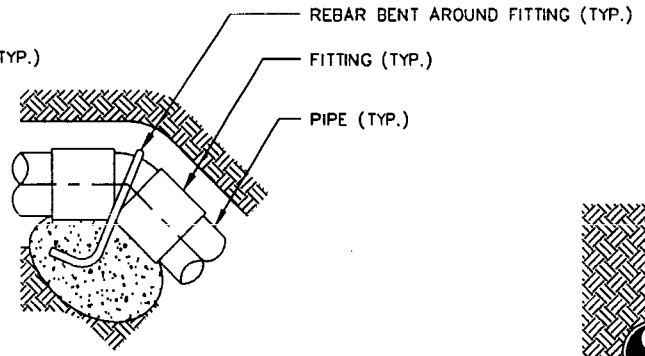

45° ELL (VERTICAL)

SCALE: NTS

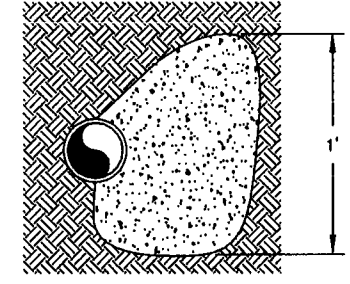
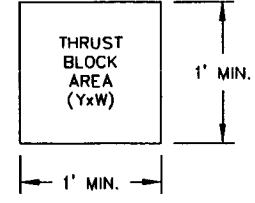

SECTION A

REVISED: 1/11/00

REVISED: 2/27/02

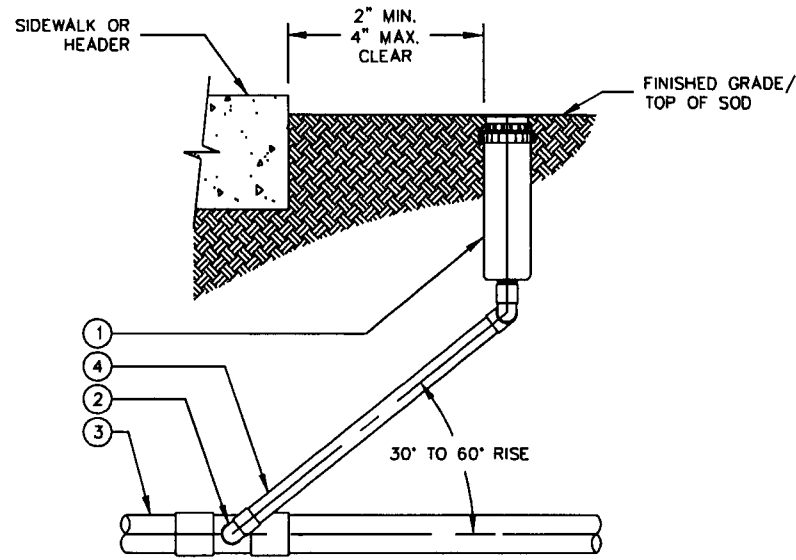

**SWING JOINT ASSEMBLY
ELEVATION**

SCALE: NTS

LIST OF MATERIALS

- ① ROTOR SPRINKLER HEAD
- ② STREET ELL (1 OF 3) SCH 40 PVC
- ③ PVC LATERAL PIPE
- ④ SCH 80 NIPPLE TBE

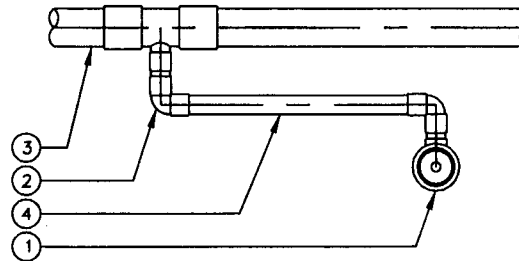

SWING JOINT ASSEMBLY PLAN

SCALE: NTS

NOTES

- 1. SWING JOINT TO BE THE SAME SIZE AS SPRINKLER HEAD INLET.
- 2. NO PRE-FAB SWING JOINTS
- 3. NO MARLEX FITTINGS

DETAIL NO.
2644

City of Scottsdale
Standard Details

APPROVED BY:
Scottsdale Standards &
Specifications Committee

ROTOR SPRINKLER ASSEMBLY

DETAIL NO.
2644

REVISED: 2/27/02

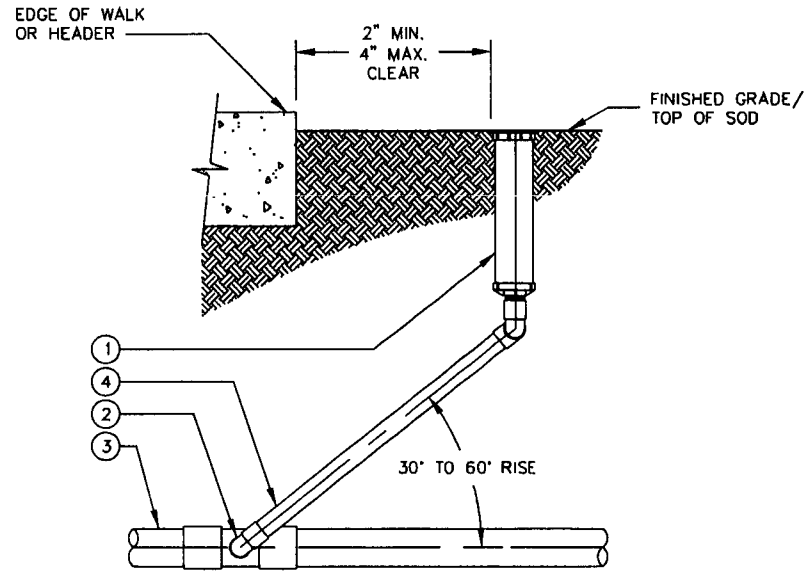

**SWING JOINT ASSEMBLY
ELEVATION**

SCALE: NTS

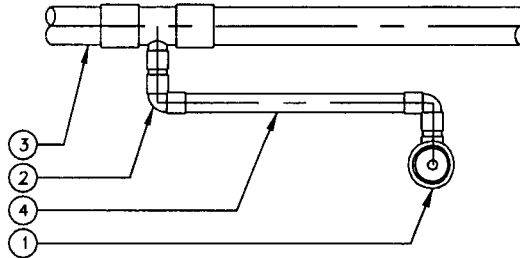

SWING JOINT ASSEMBLY PLAN

SCALE: NTS

LIST OF MATERIALS

- ① 4" POP-UP SPRAY SPRINKLER HEAD
- ② STREET ELL (1 OF 3) SCH 40 PVC
- ③ PVC LATERAL PIPE
- ④ SCH 80 NIPPLE TBE

NOTES

- 1. SWING JOINT TO BE THE SAME SIZE AS SPRINKLER HEAD INLET.
- 2. NO PRE-FAB SWING JOINTS
- 3. NO MARLEX FITTINGS

**DETAIL NO.
2645**

**City of Scottsdale
Standard Details**

APPROVED BY:
**Scottsdale Standards &
Specifications Committee**

POP-UP SPRINKLER ASSEMBLY

**DETAIL NO.
2645**

REVISED: 2/27/02

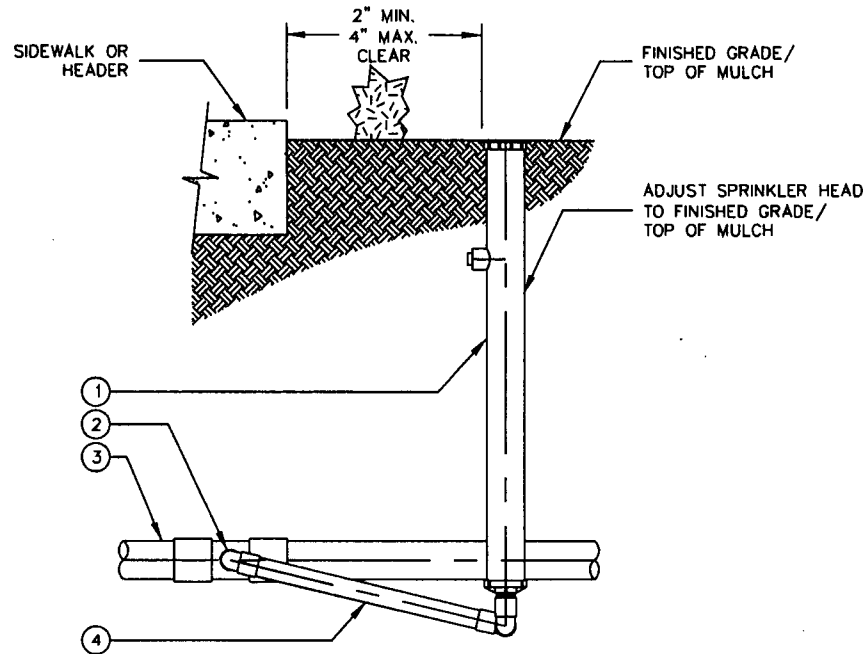

**SWING JOINT ASSEMBLY
ELEVATION**
SCALE: NTS

LIST OF MATERIALS

- ① 12" POP-UP SPRAY SPRINKLER HEAD
- ② STREET ELL (1 OF 3) SCH 40 PVC
- ③ PVC LATERAL PIPE
- ④ SCH 80 NIPPLE TBE

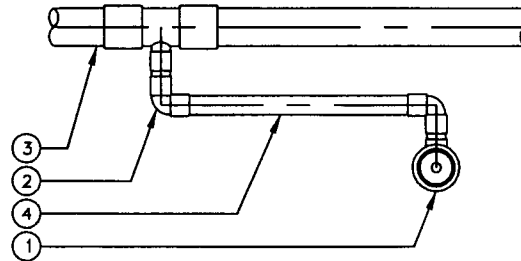

SWING JOINT ASSEMBLY PLAN
SCALE: NTS

NOTES

- 1. SWING JOINT TO BE THE SAME SIZE AS SPRINKLER HEAD INLET.
- 2. SWING JOINT SHALL BE CONNECTED TO BOTTOM OUTLET.
- 3. NO PRE-FAB SWING JOINTS
- 4. NO MARLEX FITTINGS

DETAIL NO.
2646

City of Scottsdale
Standard Details

APPROVED BY:
Scottsdale Standards &
Specifications Committee

SHRUB POP-UP SPRINKLER ASSEMBLY

DETAIL NO.
2646

REVISED: 7/15/03

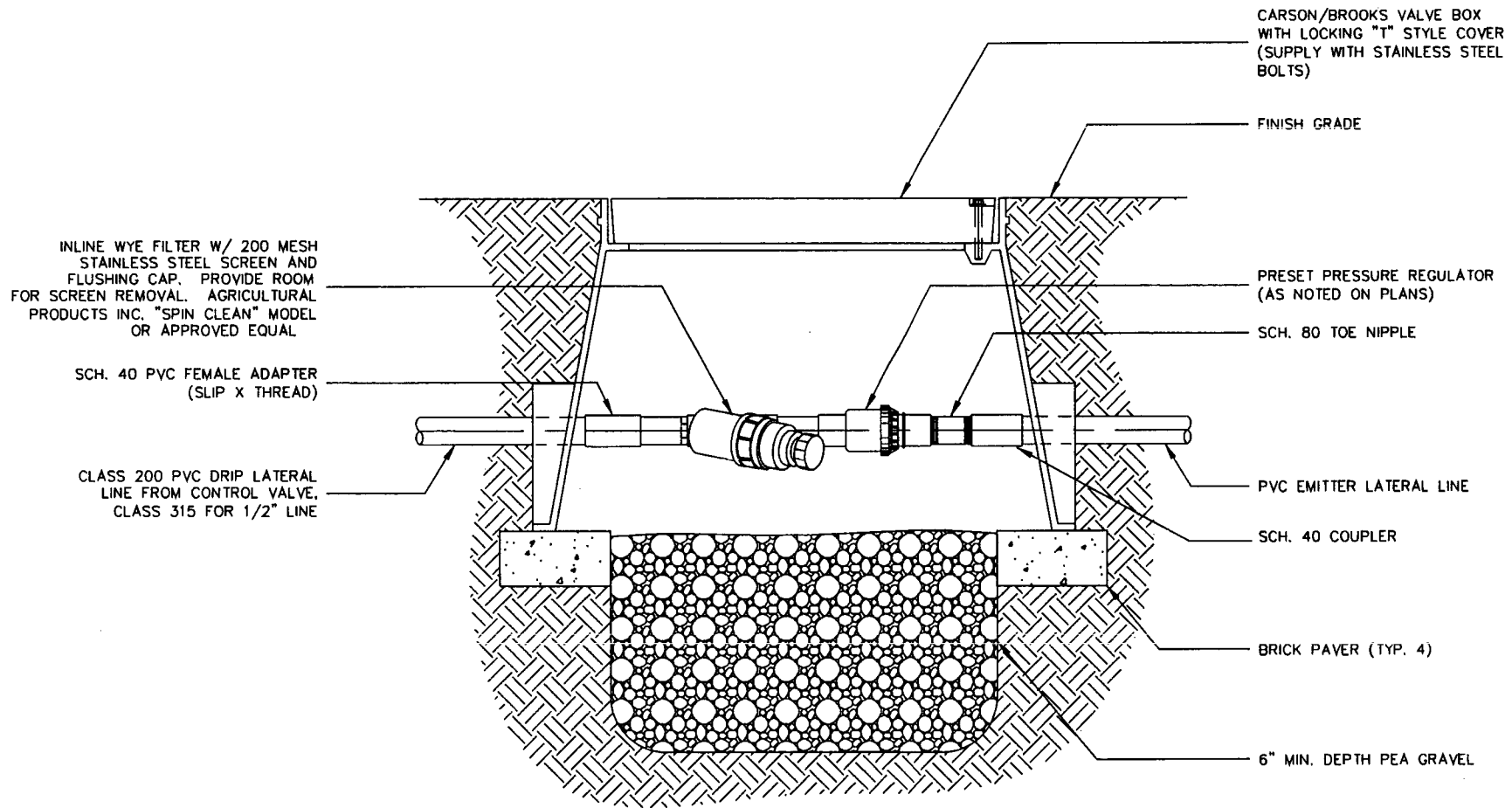

**DRIP FILTER &
PRESS. REG. ASSEMBLY**

SCALE: NTS

DETAIL NO.
2647

City of Scottsdale
Standard Details

APPROVED BY:
Scottsdale Standards &
Specifications Committee

DRIP FILTER & PRESSURE REGULATOR

DETAIL NO.
2647

REVISED: 1/5/00

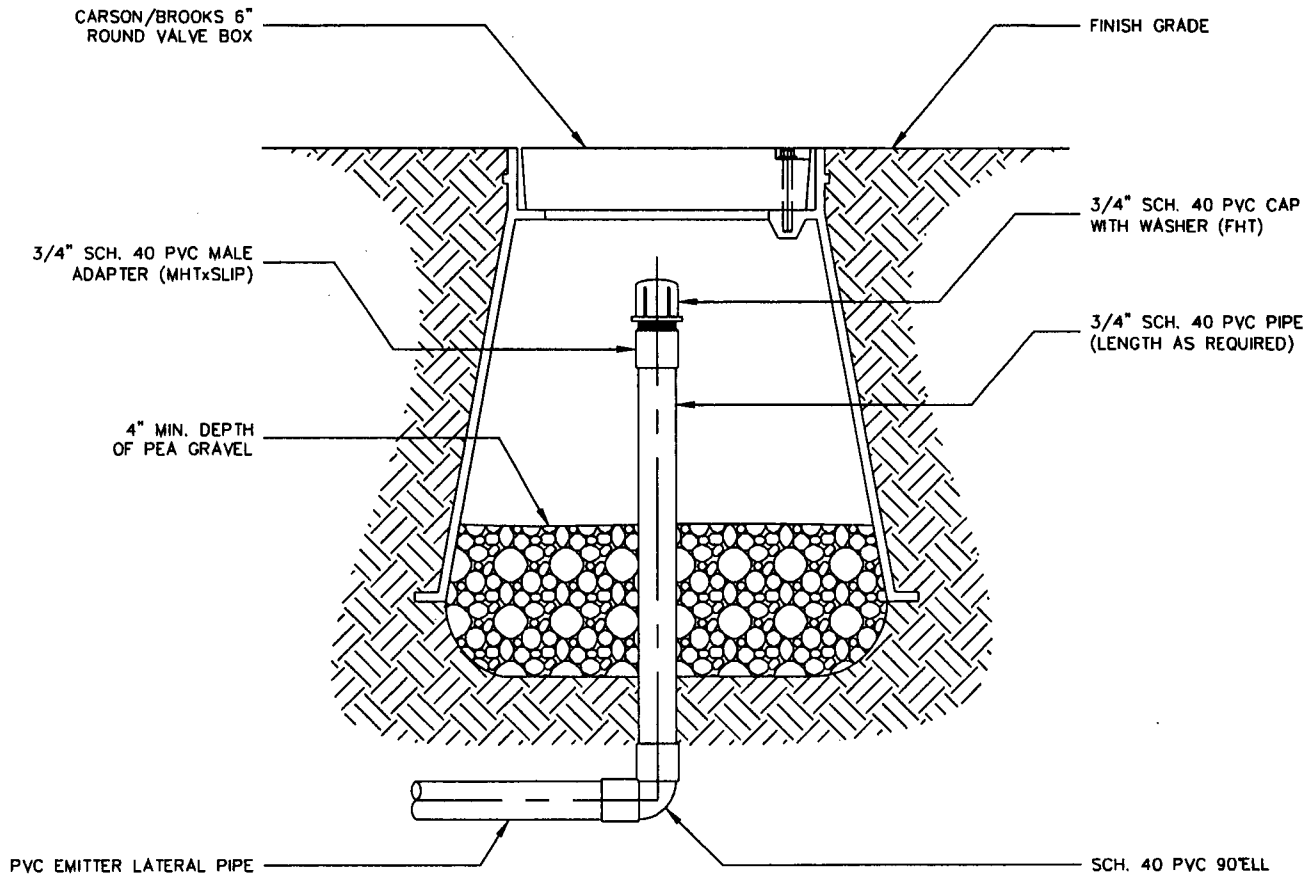

EMITTER FLUSH CAP ASSEMBLY
SCALE: NTS

DETAIL NO.
2648

City of Scottsdale
Standard Details

APPROVED BY:
Scottsdale Standards &
Specifications Committee

EMITTER FLUSH CAP ASSEMBLY

DETAIL NO.
2648

REVISED: 7/15/03

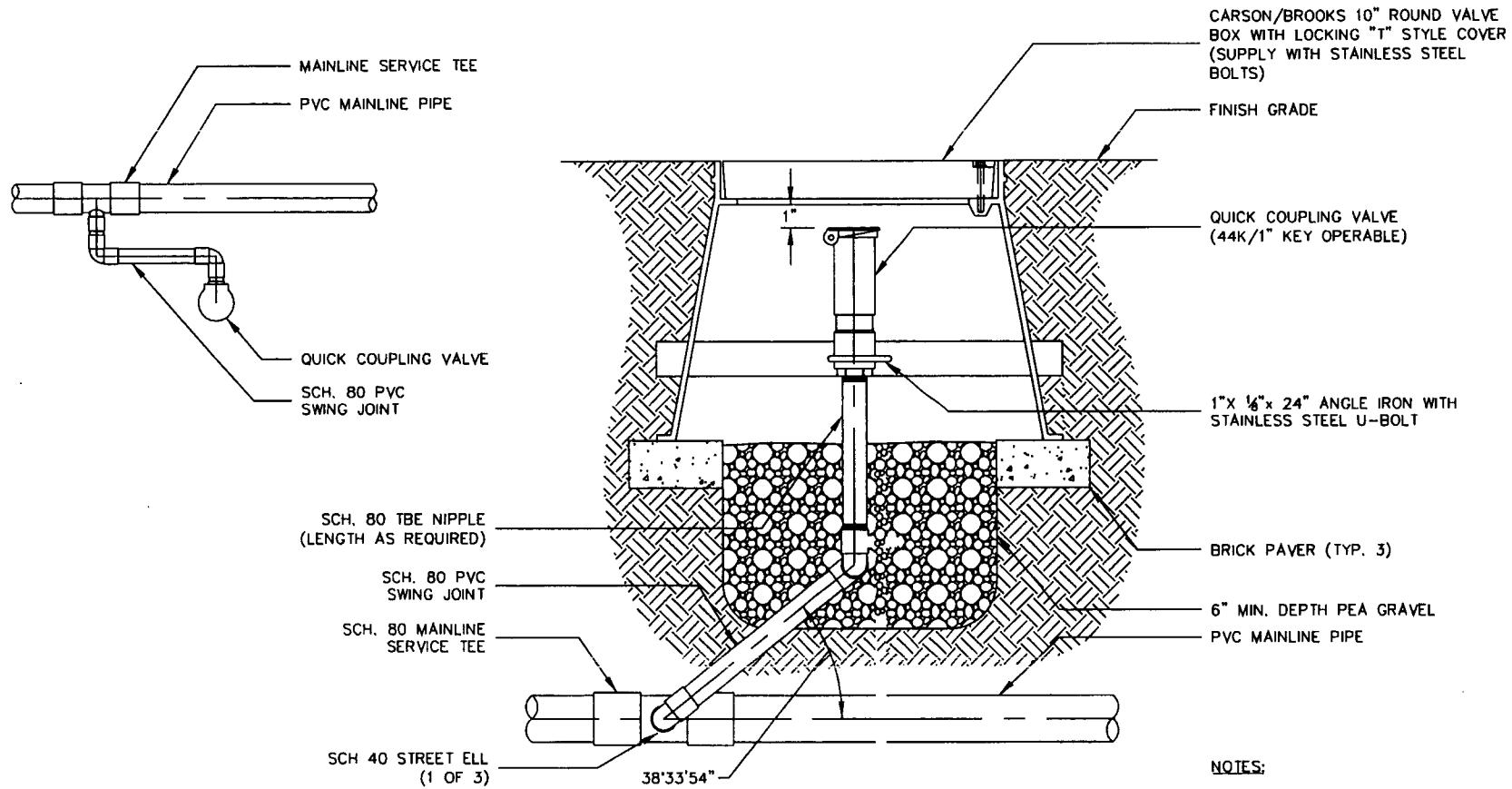

CARSON/BROOKS 10" ROUND VALVE BOX WITH LOCKING "T" STYLE COVER (SUPPLY WITH STAINLESS STEEL BOLTS)

FINISH GRADE

QUICK COUPLING VALVE (44K/1" KEY OPERABLE)

1" X 1/8" X 24" ANGLE IRON WITH STAINLESS STEEL U-BOLT

BRICK PAVER (TYP. 3)

6" MIN. DEPTH PEA GRAVEL

PVC MAINLINE PIPE

SCH. 80 TBE NIPPLE (LENGTH AS REQUIRED)

SCH. 80 PVC SWING JOINT

SCH. 80 MAINLINE SERVICE TEE

SCH. 40 STREET ELL (1 OF 3)

38'33'54"

NOTES:

1. EACH QUICK COUPLER SHALL BE IN A SEPARATE VALVE BOX.
2. SWING JOINT SHALL BE THE SAME SIZE AS QUICK COUPLER VALVE.
3. NO PRE-FAB SWING JOINTS.
4. U-BOLT TO BE SECURED WITH LOCK WASHERS AND BACK-UP LOCKING NUT.

QUICK COUPLER ASSEMBLY

SCALE: NTS

DETAIL NO. 2649

City of Scottsdale Standard Details

APPROVED BY: Scottsdale Standards & Specifications Committee

QUICK COUPLER ASSEMBLY

DETAIL NO. 2649

REVISED: 7/15/03

NOTE:

- 1. BALL VALVE SHALL MATCH NOMINAL SIZE OF MAINLINE PIPE.

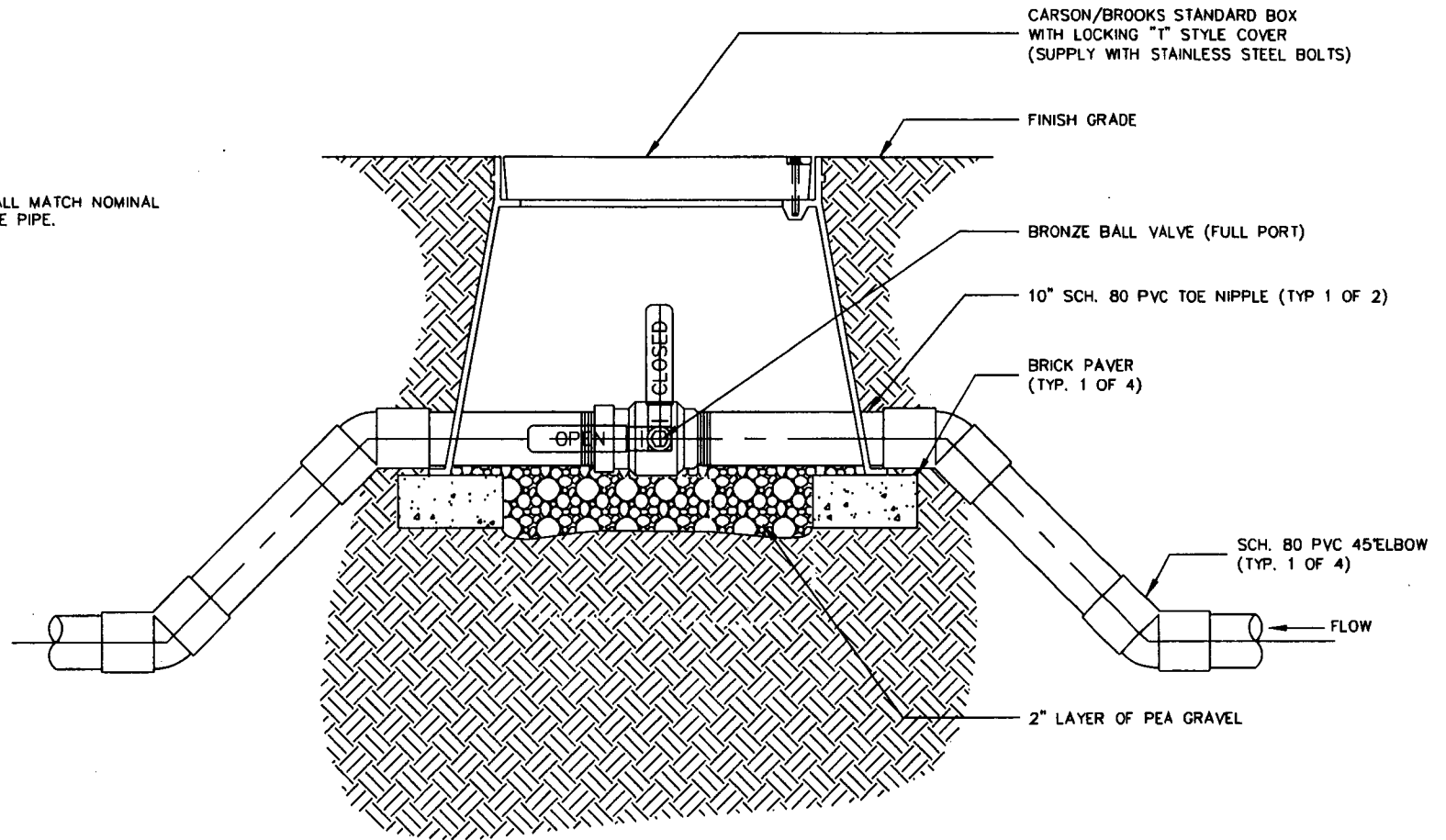

**1-1/2" & SMALLER MAINLINE
ISOLATION BALL VALVE ASSEMBLY**

SCALE: NTS

DETAIL NO.
2650

City of Scottsdale
Standard Details

APPROVED BY:
Scottsdale Standards &
Specifications Committee

1-1/2" & SMALLER MAINLINE BALL VALVE

DETAIL NO.
2650

REVISED: 7/15/03

NOTE:

- 1. GATE VALVE SHALL MATCH NOMINAL SIZE OF MAINLINE PIPE.
- 2. PROTECT VALVE BODY WITH 10MIL PLASTIC PRIOR TO INSTALLATION OF REBAR & SUPPORT BLOCK.

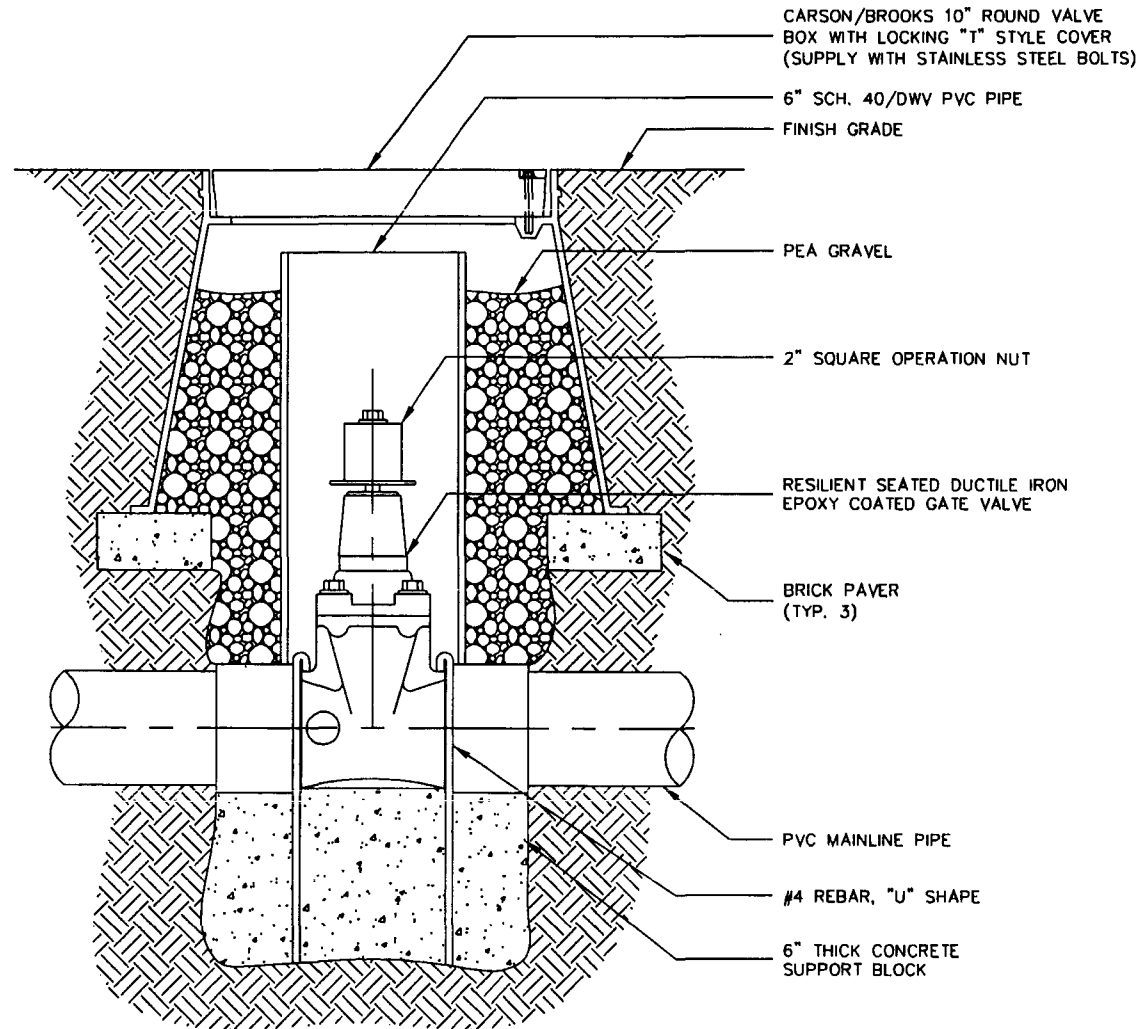

**2" & LARGER MAINLINE ISOLATION
GATE VALVE ASSEMBLY**

SCALE: NTS

**DETAIL NO.
2651**

**City of Scottsdale
Standard Details**

APPROVED BY:
**Scottsdale Standards &
Specifications Committee**

2" & LARGER MAINLINE ISOLATION GATE VALVE

**DETAIL NO.
2651**

REVISED: 7/15/03

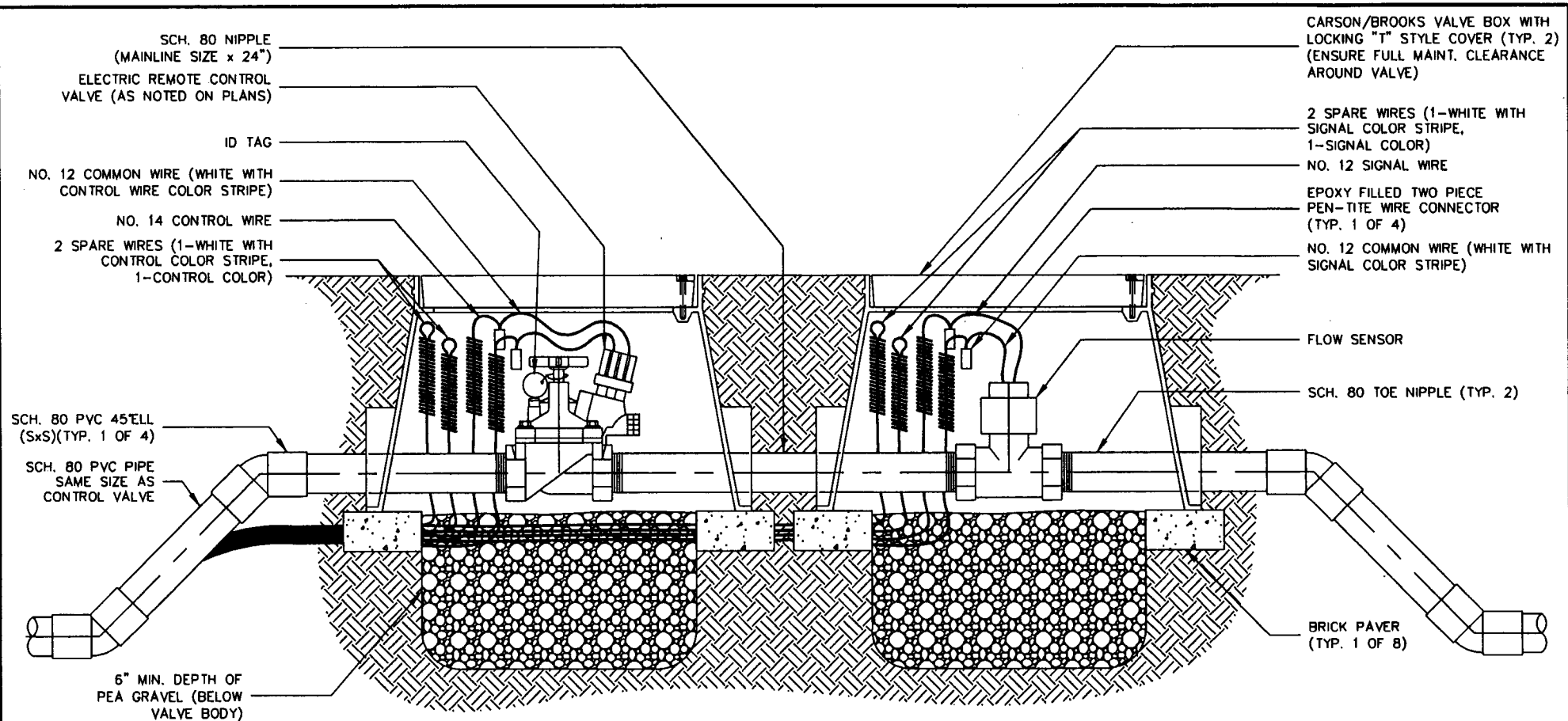

**1" MASTER VALVE/
FLOW METER ASSEMBLY**

SCALE: NTS

NOTES:

1. PROVIDE 30" SLACK WIRE IN 3/4" COILS FOR EACH WIRE ENTERING VALVE BOX.
2. INSTALL VALVE I.D. TAG WITH CONTROLLER IDENTIFICATION AND STATION NUMBER WHICH CORRESPONDS TO THE PLANS.
3. MAINTAIN 2" MIN.-4" MAX. DISTANCE BETWEEN TOP OF CONTROL VALVE AND BOTTOM OF BOX LID.
4. CONTROL AND SIGNAL WIRE FROM MASTER VALVE TO CONTROLLER TO BE SEPARATE COLOR FROM OTHER VALVE WIRE. (CONTROL AND SIGNAL COMMONS TO BE SEPARATE FROM ANY OTHERS COMMONS IN THE SYSTEM.)
5. A DATA INDUSTRIAL MODEL 600-30 PULSE OUTPUT TRANSMITTER IS REQUIRED TO BE MOUNTED INSIDE THE CONTROLLER CABINET (SEE CITY IRRIGATION SUPERVISOR FOR WIRING INFORMATION).

**DETAIL NO.
2652**

**City of Scottsdale
Standard Details**

APPROVED BY:
**Scottsdale Standards &
Specifications Committee**

1" MASTER VALVE / FLOW METER

**DETAIL NO.
2652**

REVISED: 7/15/03

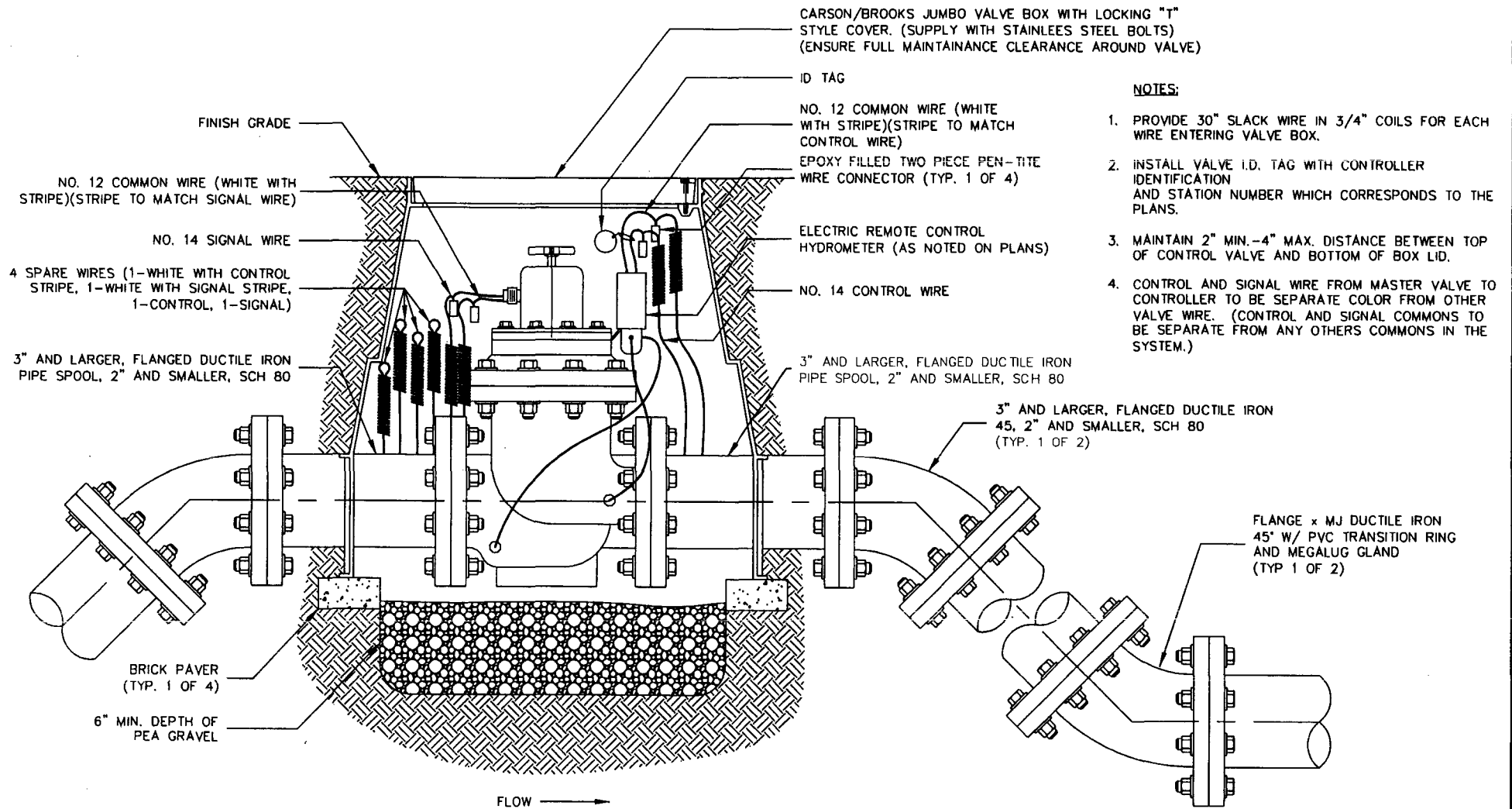

NOTES:

1. PROVIDE 30" SLACK WIRE IN 3/4" COILS FOR EACH WIRE ENTERING VALVE BOX.
2. INSTALL VALVE I.D. TAG WITH CONTROLLER IDENTIFICATION AND STATION NUMBER WHICH CORRESPONDS TO THE PLANS.
3. MAINTAIN 2" MIN.-4" MAX. DISTANCE BETWEEN TOP OF CONTROL VALVE AND BOTTOM OF BOX LID.
4. CONTROL AND SIGNAL WIRE FROM MASTER VALVE TO CONTROLLER TO BE SEPARATE COLOR FROM OTHER VALVE WIRE. (CONTROL AND SIGNAL COMMONS TO BE SEPARATE FROM ANY OTHERS COMMONS IN THE SYSTEM.)

1 1/2" LARGER MASTER VALVE / FLOW METER ASSEMBLY

SCALE: NTS

DETAIL NO.
2653

City of Scottsdale
Standard Details

APPROVED BY:
Scottsdale Standards &
Specifications Committee

1 1/2" & LARGER MASTER VALVE/FLOW METER

DETAIL NO.
2653

REVISED: 5/04/04

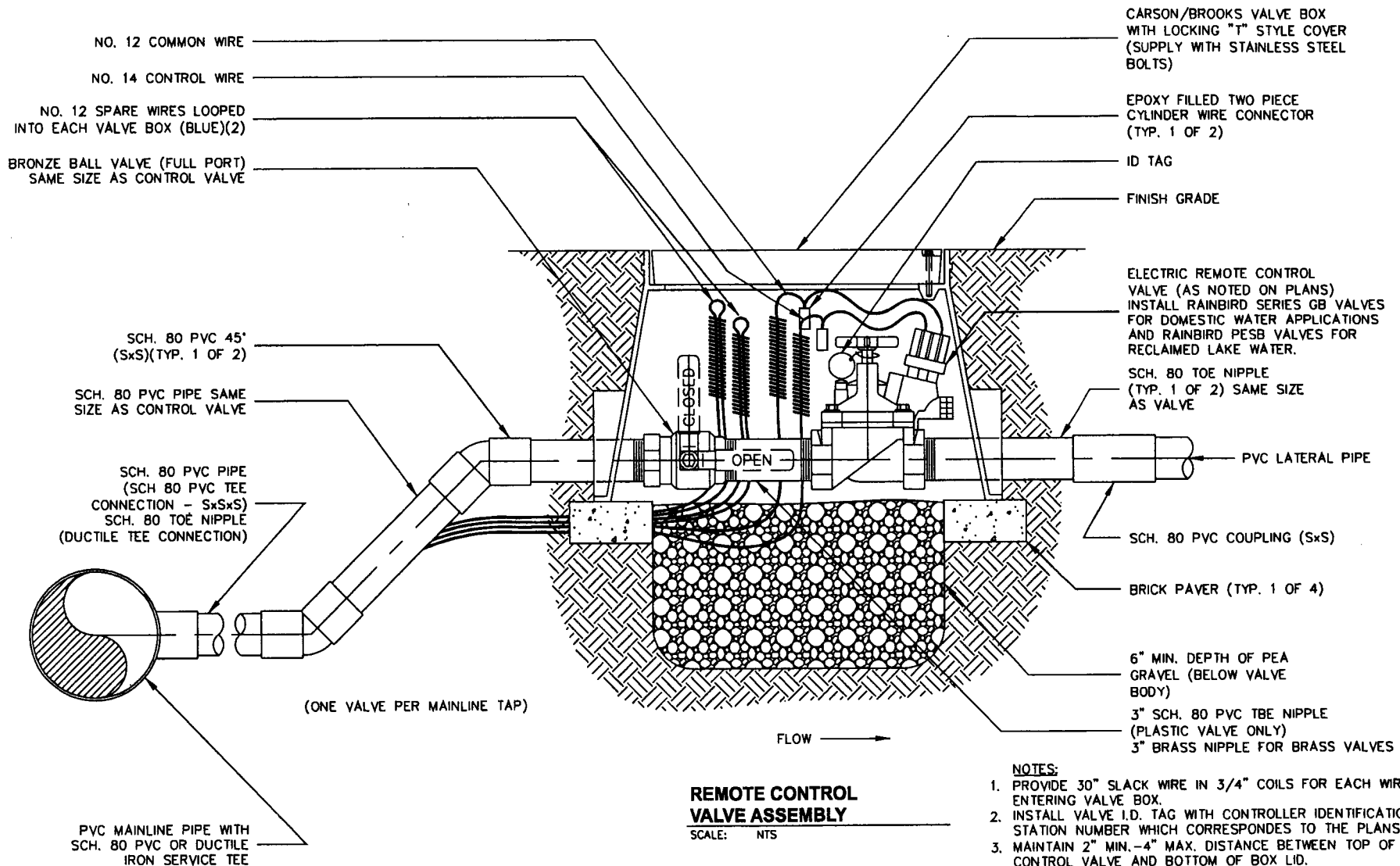

REMOTE CONTROL VALVE ASSEMBLY

SCALE: NTS

NOTES:

1. PROVIDE 30" SLACK WIRE IN 3/4" COILS FOR EACH WIRE ENTERING VALVE BOX.
2. INSTALL VALVE I.D. TAG WITH CONTROLLER IDENTIFICATION AND STATION NUMBER WHICH CORRESPONDES TO THE PLANS.
3. MAINTAIN 2" MIN.-4" MAX. DISTANCE BETWEEN TOP OF CONTROL VALVE AND BOTTOM OF BOX LID.
4. INSTALL D.C. LATCHING SOLENOIDS W/ D.C. CONTROLLERS.
5. FOR BRASS CONTROL VALVES, INSTALL 3" BRASS TBE NIPPLE BETWEEN BALL VALVE AND CONTROL VALVE

DETAIL NO. 2654

City of Scottsdale
Standard Details

APPROVED BY:
Scottsdale Standards &
Specifications Committee

REMOTE CONTROL VALVE ASSEMBLY

DETAIL NO. 2654

REVISED: 3/9/05

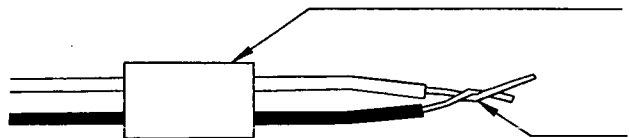

STEP 1

SLIP BASE SOCKET OVER
END OF WIRES

STRIP WIRES APPROX. 5/8" FROM
ENDS - TWIST ENDS TOGETHER

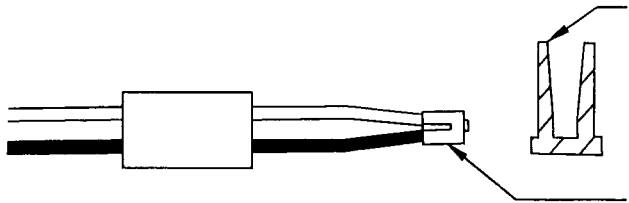

STEP 2

APPLY SEALER TO OUTSIDE OF SEALING
PLUG - FILL CAVITY WITH SEALER

PUT CRIMP SLEEVE OVER WIRE
ENDS - CRIMP SLEEVE AND CUT
OFF EXCESS WIRE

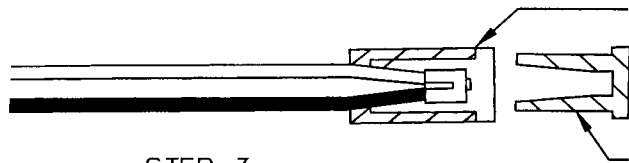

STEP 3

PULL BASE SOCKET OVER WIRE
END AS FAR AS POSSIBLE

PUSH SEALING PLUG INTO
BASE SOCKET

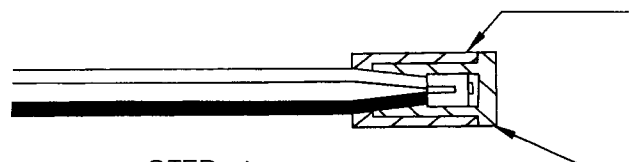

STEP 4

PUSH WIRES TO END OF BASE
SOCKET TO ASSURE COMPLETE
SEALING OF CONNECTION

DRI-SPLICE TYPE WIRE
CONNECTOR

NOTES:

1. FOR WIRE SIZES NO. 14, 12 AND 10, ALL CONNECTIONS IN VALVE BOXES ONLY.
2. INSTALL SPEARS DS-100 DRI-SPLICE CONNECTORS WITH DS-300 SEALANT.

DETAIL NO.
2655

City of Scottsdale
Standard Details

APPROVED BY:
Scottsdale Standards & Specifications Committee

TYPICAL IRRIGATION WIRE CONNECTION

DETAIL NO.
2655

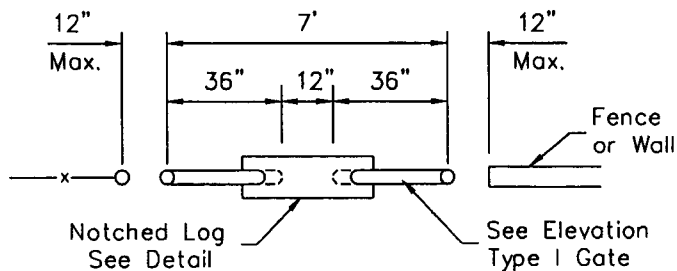

**TYPE I GATE
w/ NOTCHED LOG**

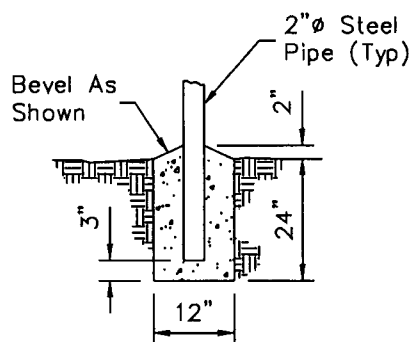

**POST FOOTING
DETAIL**

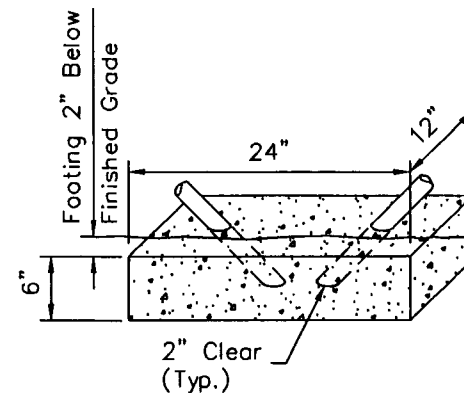

**GATE FOOTING
DETAIL**

NOTES:

1. All Concrete Shall Be Class "B".
2. Paint Rails Per ADOT Specifications. Color Per Plans.
3. Treated Wood Per MAG Section 779.

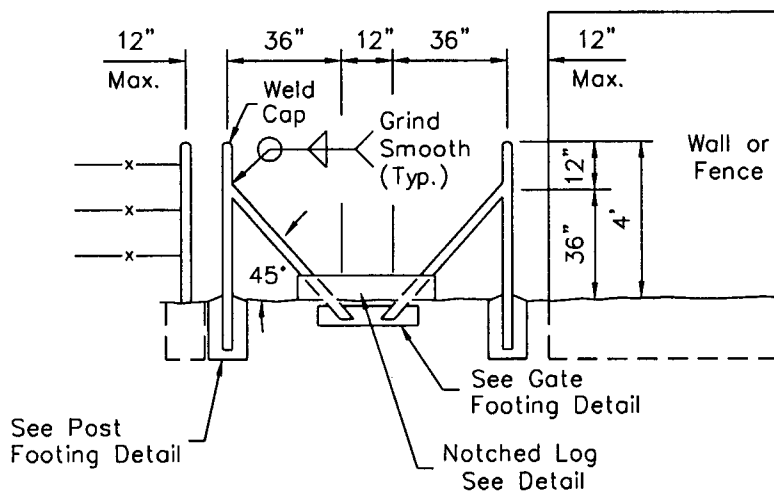

**ELEVATION
TYPE I GATE**

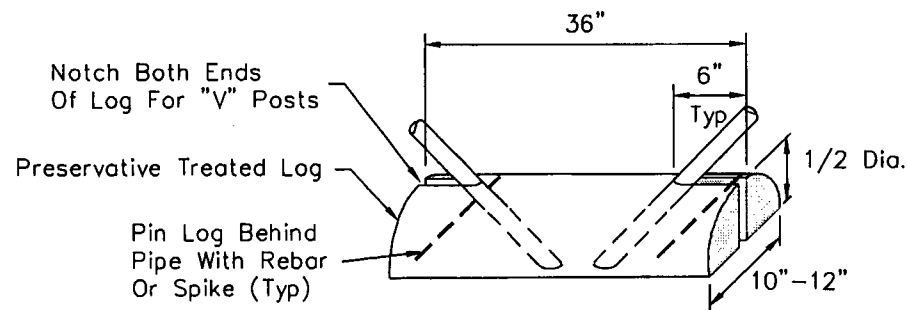

NOTCHED LOG DETAIL

DETAIL NO.
2680-1

**City of Scottsdale
Standard Details**

APPROVED BY:
**Scottsdale Standards &
Specifications Committee**

TRAIL ACCESS GATES

DETAIL NO.
2680-1

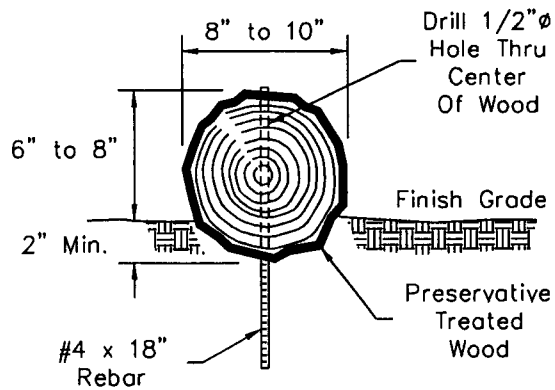

**REBAR SECURED
WOOD BARS**

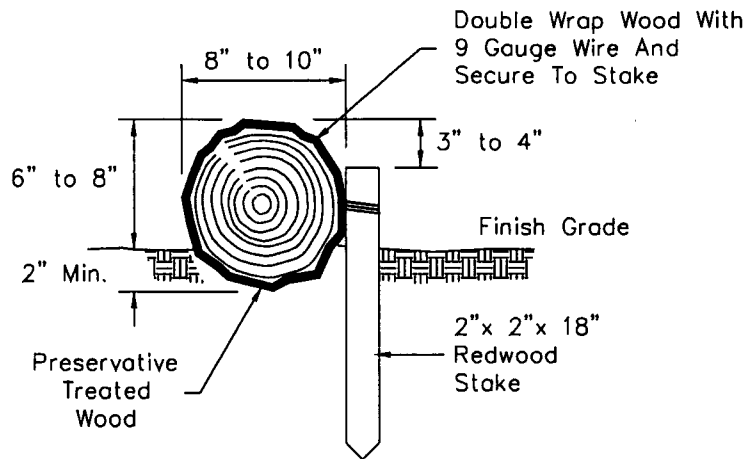

**WIRE SECURED
WOOD BARS**

NOTES:

1. Provide water bars at a maximum 100' interval where trail grade is equal to or greater than 6% and at all locations as shown on plans.
2. Treated wood per MAG Section 779.

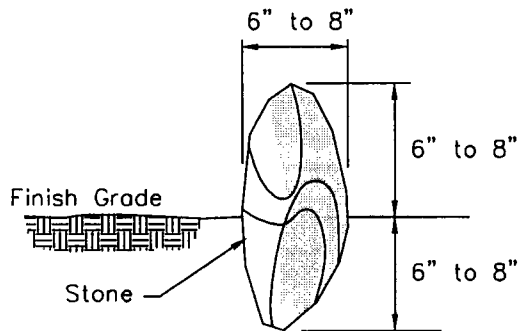

Stagger Stones To Provide
A Continuous Water Bar

STONE BARS

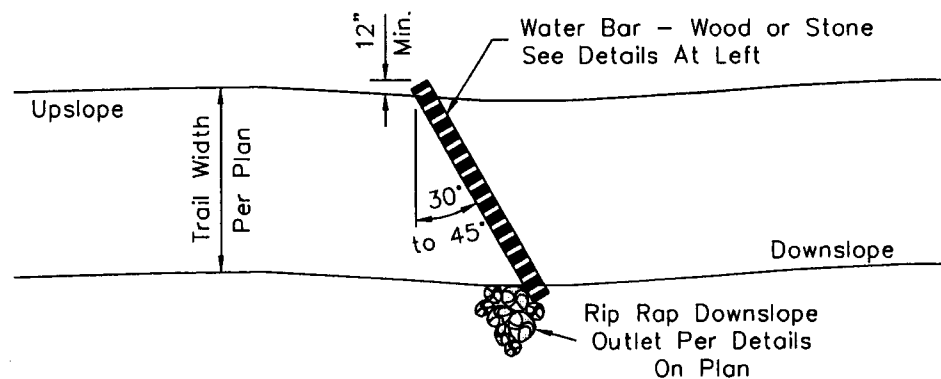

**WATER BARS
PLAN**

DETAIL NO.
2681

**City of Scottsdale
Standard Details**

APPROVED BY:
**Scottsdale Standards &
Specifications Committee**

TRAIL WATER BARS

DETAIL NO.
2681

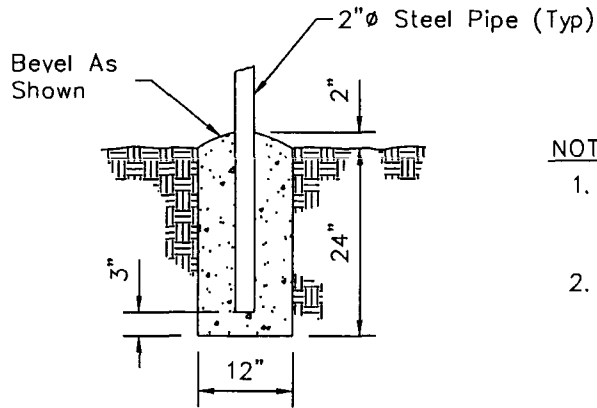

CONCRETE FOOTING DETAIL

- NOTES:**
1. Point Rails Per ADOT Specifications. Color Per Plan.
 2. Treated Wood Posts Per MAG Section 779.

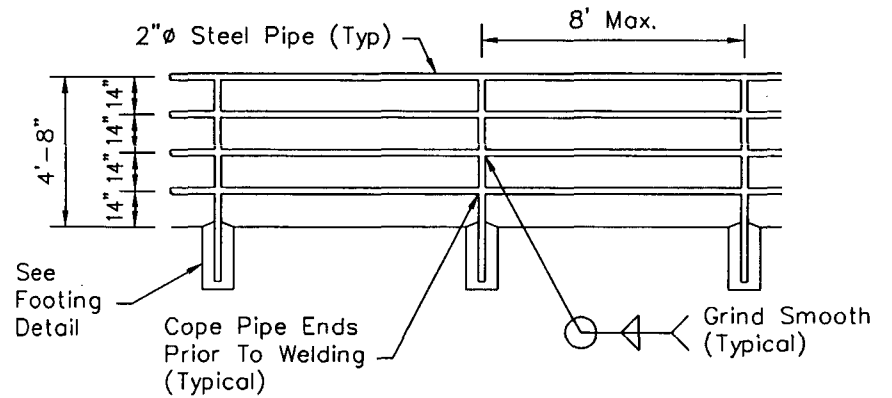

STEEL RAIL

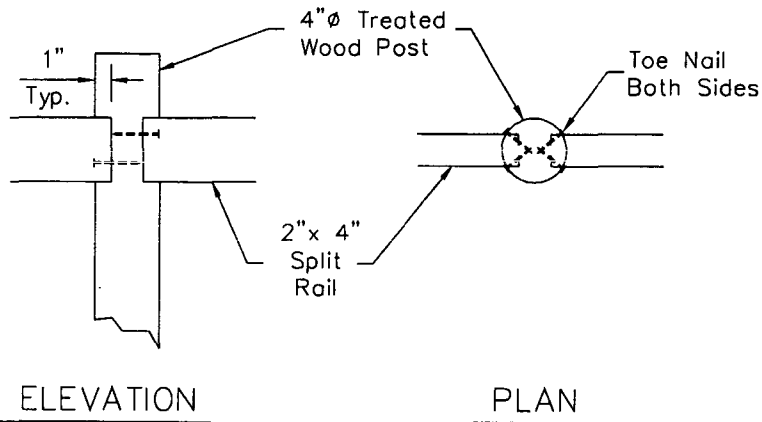

POST CONNECTION DETAIL

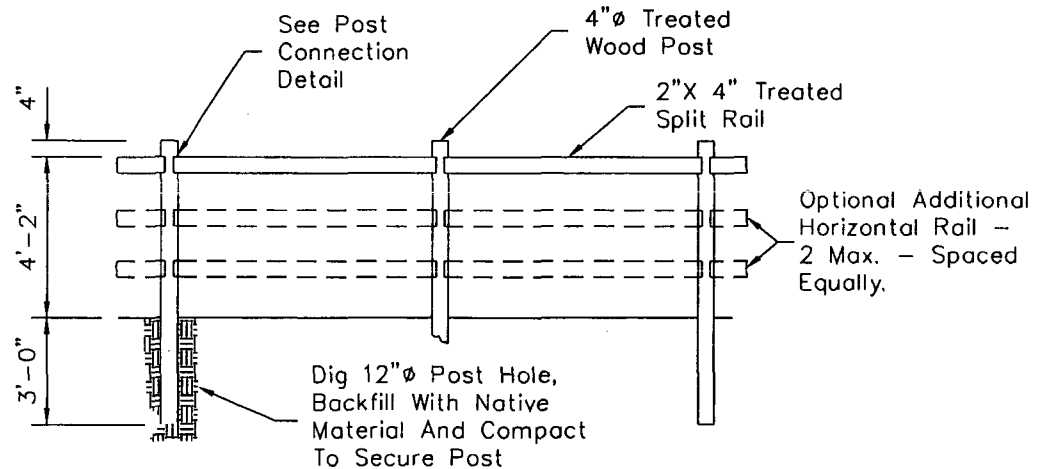

POST AND RAIL

DETAIL NO.
2682

**City of Scottsdale
Standard Details**

APPROVED BY:
**Scottsdale Standards &
Specifications Committee**

TRAIL SAFETY BARRIERS

DETAIL NO.
2682

NOTES:

1. Signs shall conform to C.O.S. Supplemental Specifications, Section 402.3.
2. Signs to be mounted on square perforated tubing per C.O.S. Std Det 2131 within C.O.S. Right-of-Way. Treated wood post may be used for trail markers located outside C.O.S. Right-of Way.
3. Legends shall be reflectorized white vinyl sheeting on a green or brown vinyl background unless otherwise approved by the City of Scottsdale.

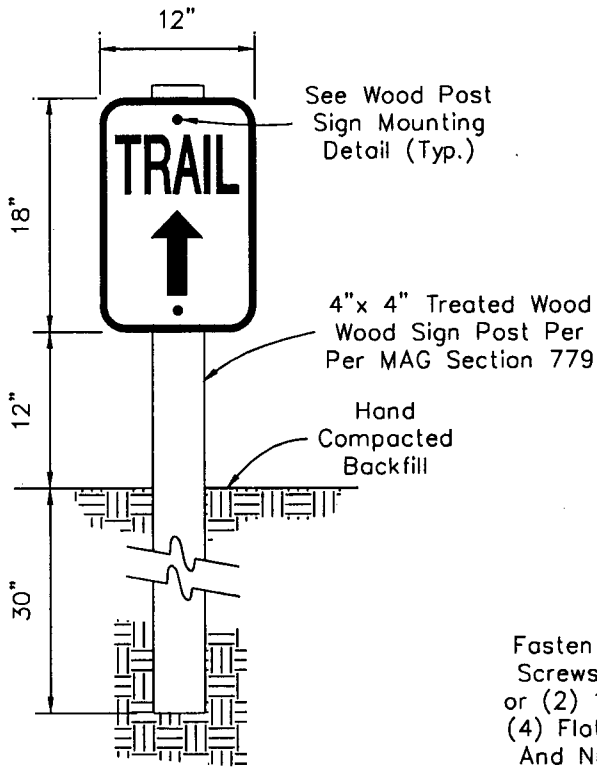

TRAIL MARKER

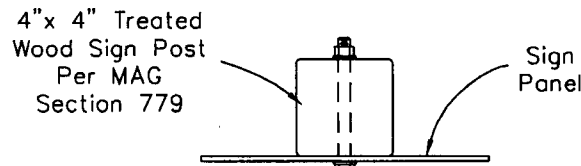

Fasten With (2) 1/2" x 2" Lag Screws With (2) Flat Washers or (2) 1/2" x 4 1/2" Bolts With (4) Flat Washers. Burr Threads And Nuts With Center Punch.

WOOD POST SIGN MOUNTING DETAIL

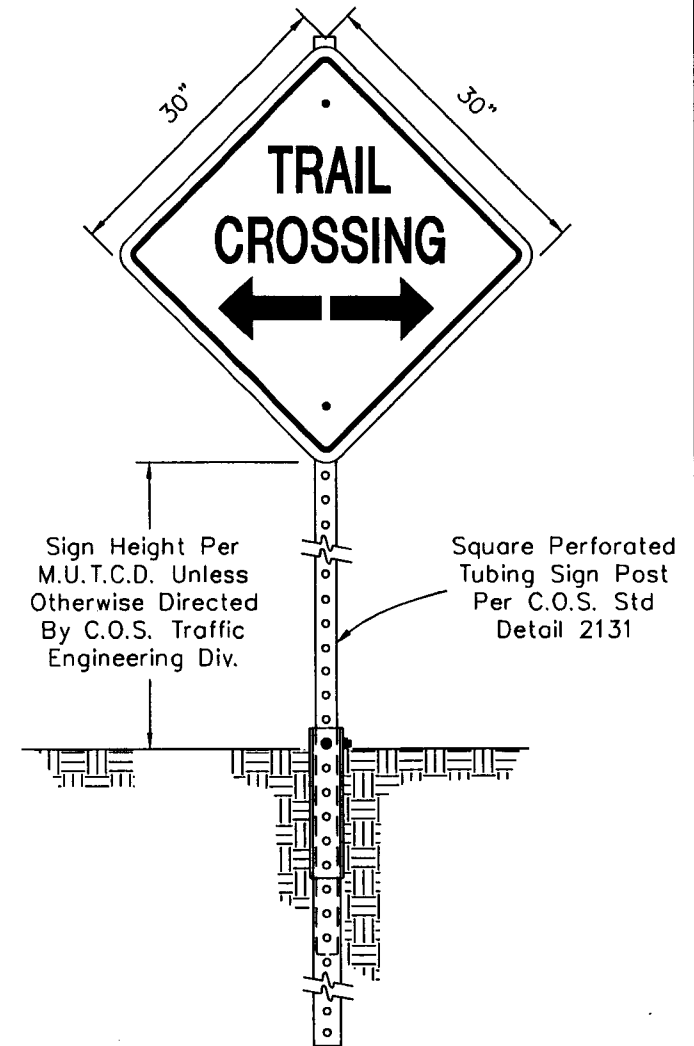

TRAIL CROSSING SIGN

DETAIL NO.
2683

**City of Scottsdale
Standard Details**

APPROVED BY:
**Scottsdale Standards &
Specifications Committee**

TRAIL SIGNS

DETAIL NO.
2683